

2 ( 'x ' ) CONCRETE BOX CULVERT

SEC/SUR \* TWP \* RGE \*

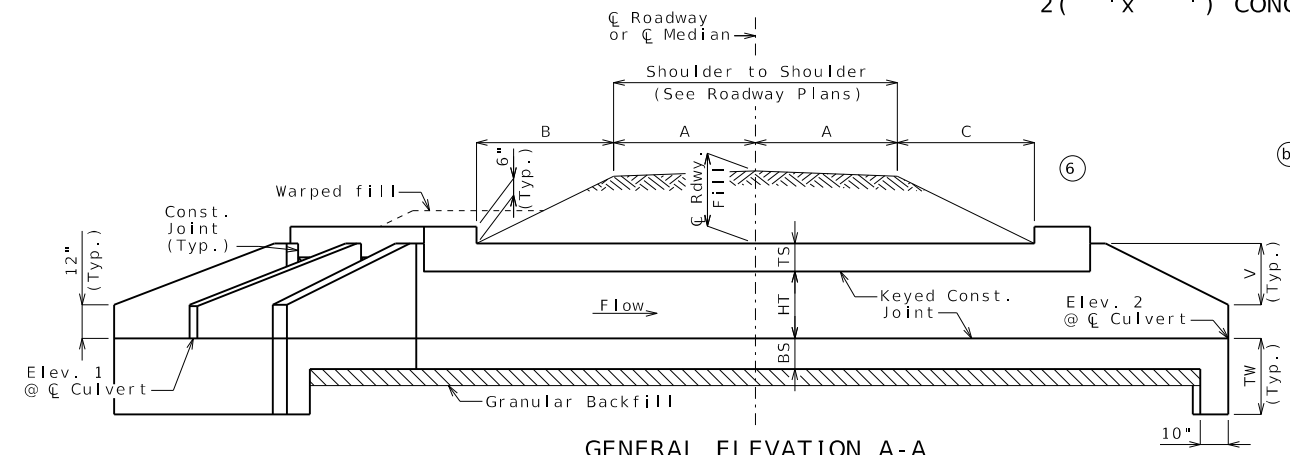

GENERAL ELEVATION A-A

Construction joint key not shown for clarity, see standard plans for details.

If any part of the barrel is exposed, the roadway fill shall be warped to provide 12 inches minimum cover. (Roadway Item)

If unsuitable material is encountered, excavation of unsuitable material and furnishing and placing of granular backfill shall be in accordance with Sec 206.

| Var. | Equation                 | Dim. | Var. | Equation                  | Dim. | Var. | Equation                                     | Dim. |
|------|--------------------------|------|------|---------------------------|------|------|--|------|
| S    | - - -                    | x    | K    | $(S + T1/2)(\sec Z)$      | x    | BB   | $(A + B)(\sec Z)$                            | x    |
| HT   | - - -                    | x    | L    | $AA + BB + CC + DD + EE$  | x    | CC   | $(A + C)(\sec Z)$                            | x    |
| TS   | - - -                    | x    | M    | $N(\cos 20^\circ)$        | x    | DD   | $R + M + N + 20"$                            | x    |
| BS   | - - -                    | x    | N    | $3" + TX(\tan 10^\circ)$  | x    | EE   | $E(\sec Z)$                                  | x    |
| TX   | - - -                    | x    | O    | $I + YY$                  | x    | HH   | $20"(\sec Z)$                                | x    |
| T1   | - - -                    | x    | P    | $2V[\sec(Z + 20^\circ)]$  | x    | II   | $20"(\cos Z)$                                | x    |
| A    | - - -                    | x    | Q    | $TX(\cos 20^\circ)$       | x    | KK   | $S + T1/2 + U$                               | x    |
| B    | - - -                    | x    | R    | $P(\cos 20^\circ)$        | x    | LL   | $(AA + BB + DD)(\cos Z)$                     | x    |
| C    | - - -                    | x    | T    | $G(\sec Z)$               | x    | MM   | $3"[\cos Z + \cos(Z - 20^\circ)]$            | x    |
| D    | $II + MM + RR + TT$ (7)  | x    | U    | $(R + M)(\tan 20^\circ)$  | x    | QQ   | $TX(\cos Z)$                                 | x    |
| E    | $G + O + 20"$            | x    | V    | $HT + TS - 12"$           | x    | RR   | $P[\cos(Z - 20^\circ)]$                      | x    |
| F    | $2S + 2TX + T1$ (b)      | x    | W    | $2A + B + C + D + E + SS$ | x    | SS   | $F(\sin Z)$                                  | x    |
| G    | $2V$                     | x    | X    | $3" + TX(\tan Z)$         | x    | TT   | $TX[\sin(20^\circ - Z)]$ (7)                 | x    |
| H    | $(A + C + E)(\tan Z)$    | x    | Y    | $TX(\sin 20^\circ)$       | x    | YY   | $TX(\sin Z)$                                 | x    |
| I    | $3"(\cos Z)$             | x    | Z    | Skew Angle                | x    | TW   | $\text{Max}\{3'-4" \text{ or } (BS + 12")\}$ | x    |
| J    | $(AA + BB + DD)(\sin Z)$ | x    | AA   | $F(\tan Z)/2$             | x    |      |  |      |

|   |
|---|
| Drainage Area = ___ mi <sup>2</sup>     |
| Design Flood Frequency = ___ years      |
| Design Flood Discharge = ___ cfs        |
| Design Flood (D.F.) Elevation = _____   |
| <b>Base Flood (100-year)</b>            |
| Base Flood Elevation = _____            |
| Base Flood Discharge = ___ cfs          |
| Estimated Backwater = __ ft             |
| Outlet Velocity = __ ft/s               |
| <b>Roadway Overtopping</b>              |
| Overtopping Flood Discharge = ___ cfs   |
| Overtopping Flood Frequency = ___ years |
| _____ Flood Elevation = _____           |

|                              |
|------------------------------|
| Upstream (Elev. 1) = _____   |
| Downstream (Elev. 2) = _____ |
| Pr. Gr. at Tie Sta. = _____  |

|                                |
|--------------------------------|
| Ⓢ Rdwy at Ⓢ Culvert = _____ ft |
| Design (All units) = _____ ft  |

Dimensions are based on end units. Fill heights are measured from the top of top slab to the top of earth fill or roadway.

|                                      | Final      |
|--------------------------------------|------------|
| Class 4 Excavation                   | cu. yard x |
| Removal of Bridges                   | lump sum 1 |
| Class B-1 Concrete (Culverts-Bridge) | cu. yard x |
| Reinforcing Steel (Culverts-Bridge)  | pound x    |

General Notes:

Design Specifications: 2010 AASHTO LRFD Bridge Design Specifications and 2010 Interim Revisions

Design Loading: Vehicular = HL-93 minus lane load, Earth = 120 lb/cf Equivalent Fluid Pressure = 30 lb/cf (min.), 60 lb/cf (max.)

Design Unit Stresses: Class B-1 Concrete (Box Culvert) f'c = 4,000 psi Reinforcing Steel (ASTM A615 Grade 60) fy = 60,000 psi

Standard Plans: 703.37, 703.45, 703.46, 703.47 (4)

Miscellaneous: MoDOT Construction personnel will indicate the type of box culvert constructed:  
 Precast Concrete Box used  
 Cast-in-Place Concrete Box used

When alternate precast concrete box sections are used, the minimum distance from inside face of headwalls to precast sections measured along the shortest wall shall be 3 feet. Reinforcement and dimensions for wings and headwalls shall be in accordance with Missouri Standard Plans.

Channel bottom shall be graded within the right of way for transition of channel bed to culvert openings. Channel banks shall be tapered to match culvert openings. (Roadway Item)

Traffic Handling: Structure to be closed during construction. Traffic to be maintained on \_\_\_\_\_ during construction. See roadway plans for traffic control.

B.M.

CULVERT-BRIDGE: ROUTE \* OVER \*  
 ROUTE \* FROM \* TO \*  
 ABOUT \* MILES \* OF \*  
 TIE STA. \_\_\_\_\_

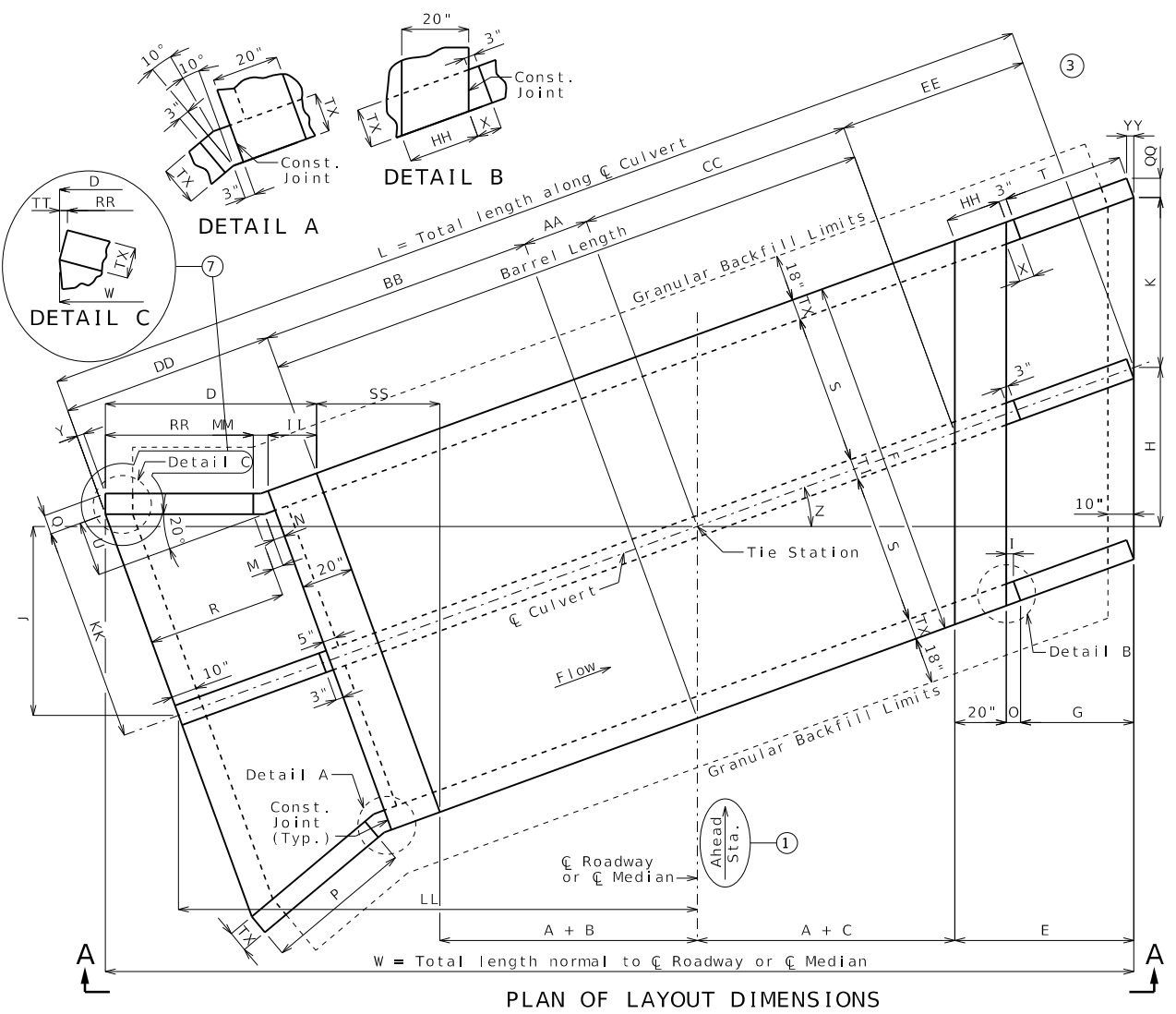

PLAN OF LAYOUT DIMENSIONS

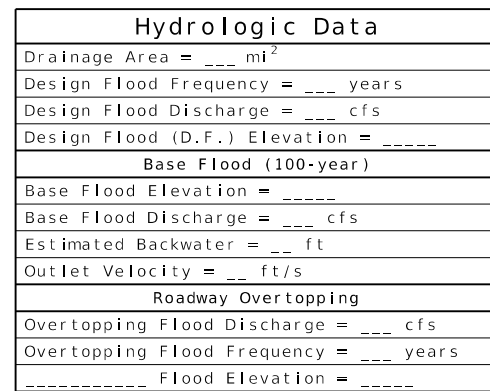

LOCATION SKETCH

Designed  
 Detailed  
 Checked

Note: This drawing is not to scale. Follow dimensions.

Sheet No. 1 of

|  |                |
|--|----------------|
| DATE PREPARED<br>12/18/2024  |                |
| ROUTE  | STATE<br>MO    |
| DISTRICT   | SHEET NO.<br>6 |
| COUNTY   |                |
| JOB NO.  |                |
| CONTRACT ID.   |                |
| PROJECT NO.  |                |
| BRIDGE NO.   |                |
| DESCRIPTION  |                |
| DATE   |                |
| MISSOURI HIGHWAYS AND TRANSPORTATION COMMISSION                                  |                |
|  |                |
| 105 WEST CAPITOL<br>JEFFERSON CITY, MO 65102<br>1-888-ASK-MODOT (1-888-275-6636) |                |

**Pipes With Same Diameter**

| XX" Pipe Inlet Data |           |            |
|---------------------|-----------|------------|
| Station             | Offset    | F.L. Elev. |
| xx+xx.xx            | xx.xx' XX | xxx.xx     |
| xx+xx.xx            | xx.xx' XX | xxx.xx     |
| xx+xx.xx            | xx.xx' XX | xxx.xx     |

**Inlets Sized for Elevation A-A (Pipe Diameter/Culvert HT)**

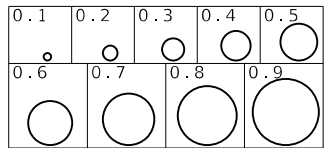

**Pipes With Different Diameters**

| Pipe Inlet Data |           |      |            |
|-----------------|-----------|------|------------|
| Station         | Offset    | Dia. | F.L. Elev. |
| xx+xx.xx        | xx.xx' XX | xx"  | xxx.xx     |
| xx+xx.xx        | xx.xx' XX | xx"  | xxx.xx     |
| xx+xx.xx        | xx.xx' XX | xx"  | xxx.xx     |

Supplemental Reinforcement Table (Nonstandard culverts with only one design fill height) ⑤

| Top Slab Reinforcement |      |         |      |    |    |         |      |         |     | Bottom Slab Reinforcement |    |         |      |         |    | Wall Reinforcement |         |    |     |      |    |   |
|------------------------|------|---------|------|----|----|---------|------|---------|-----|---------------------------|----|---------|------|---------|----|--------------------|---------|----|-----|------|----|---|
| A1 Bars                |      | J3 Bars |      |    |    | H1 Bars |      | H2 Bars |     | A2 Bars                   |    | J4 Bars |      | H3 Bars |    | B1 Bars            | B2 Bars |    |     |      |    |   |
| Sz.                    | Spa. | Sz.     | Spa. | C1 | K2 | Sz.     | Spa. | C5      | Sz. | Spa.                      | C6 | Sz.     | Spa. | C4      | K3 | Sz.                | Spa.    | C7 | Sz. | Spa. | G1 |   |
| x                      | x    | x       | x    | x  | x  | x       | x    | x       | x   | x                         | x  | x       | x    | x       | x  | x                  | x       | x  | x   | x    | x  | x |

Substitute table for tables shown on Standard Plan 703.47

Standard Drawing Guidance  
(Do not show on plans. Turn off the Bridge Construction level to hide)

Some details have been grouped together to allow easy substitution with alternate details. To edit grouped details, select them and press <Ctrl> U.

- Ahead station is shown for streams flowing left to right. Arrow must be flipped for streams that flow right to left.
- Modify Estimated Quantities as required. Don't leave blank rows but leave space between Estimated Quantities and General Notes for at least one pay item to be added during construction. See Alternate Details for culvert extensions, or if five items are required.
- Add any required transverse joints proportionally spaced along the barrel. Label units and add actual lengths of units along the barrel.
- Insert STD 703.60 when pipe inlets are required. Add pipe inlets to Plan of Layout Dimensions at appropriate locations and to Elevation A-A if visible from elevation. Add inlet data using notes where space allows, or use tables.
- For nonstandard culverts with only one design fill height, add supplemental reinforcement table.
- No need to revise General Elevation A-A for dual roadways. In Fill Heights table add a lane designation after @ Rdwy and insert another row for the other lane.
- For skews 20° or more, remove Detail C, remove TT from the equation for D and place "N/A" in the Dim. column for Dim. TT. Will first need to drop Detail C from group by selecting it, then pressing <Ctrl> U.

- \*\*\* VARIABLE DESIGN FILL HEIGHTS \*\*\*
- Select and delete the details grouped with the Fill Heights table. Select and move the alternate grouped details to drawing.
  - Place "See Member Thickness table" in the Equation column and place "Varies" in the Dim. column. If Dimension F varies, place "Varies" in the Dim. column.
  - Remove blank rows. End units may have different design fill heights but both units need to have the same member thicknesses.
  - This portion of table required when design fill height exceeds limits of the standard plans or when culvert cell height or span is not standard. If only a portion of the units are nonstandard, fill out entire table using the values from the standard table where applicable. Omit if not required.

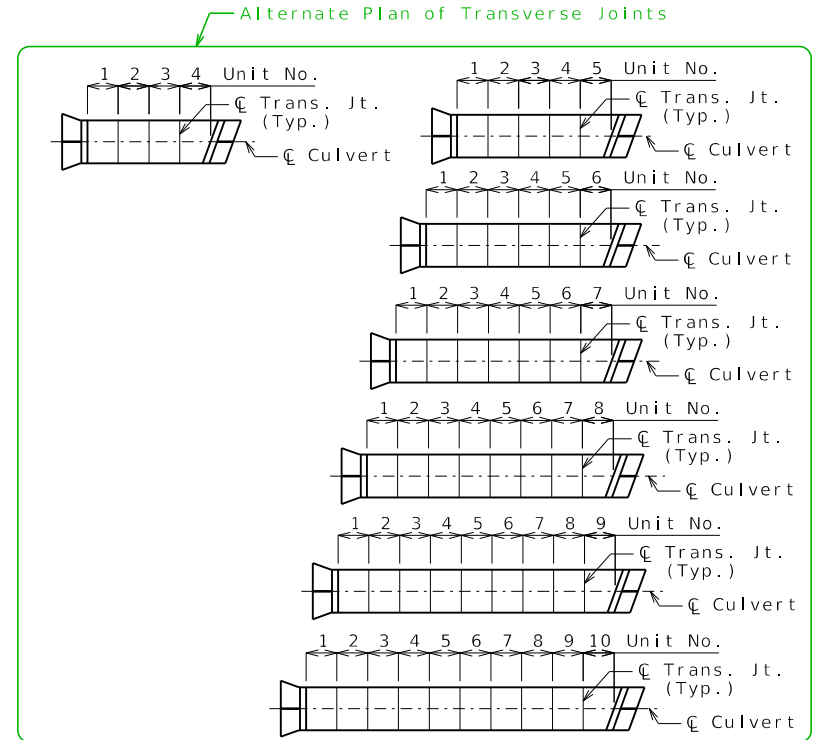

If any part of the barrel is exposed, the roadway fill shall be provided to provide 12 inches minimum cover. (Roadway Item)

Construction joint key not shown for clarity, see standard plans for details.

If unsuitable material is encountered, excavation of unsuitable material and furnishing and placing of granular backfill shall be in accordance with Sec 206.

BXC06\_dbI\_ra\_fla

Guidance & Alternate Details (2 of 2)

Corresponds to the border of the standard drawing for ease in moving alternate details (Snap to corner)

Alternate Details for Multiple Design Fill Heights (a)

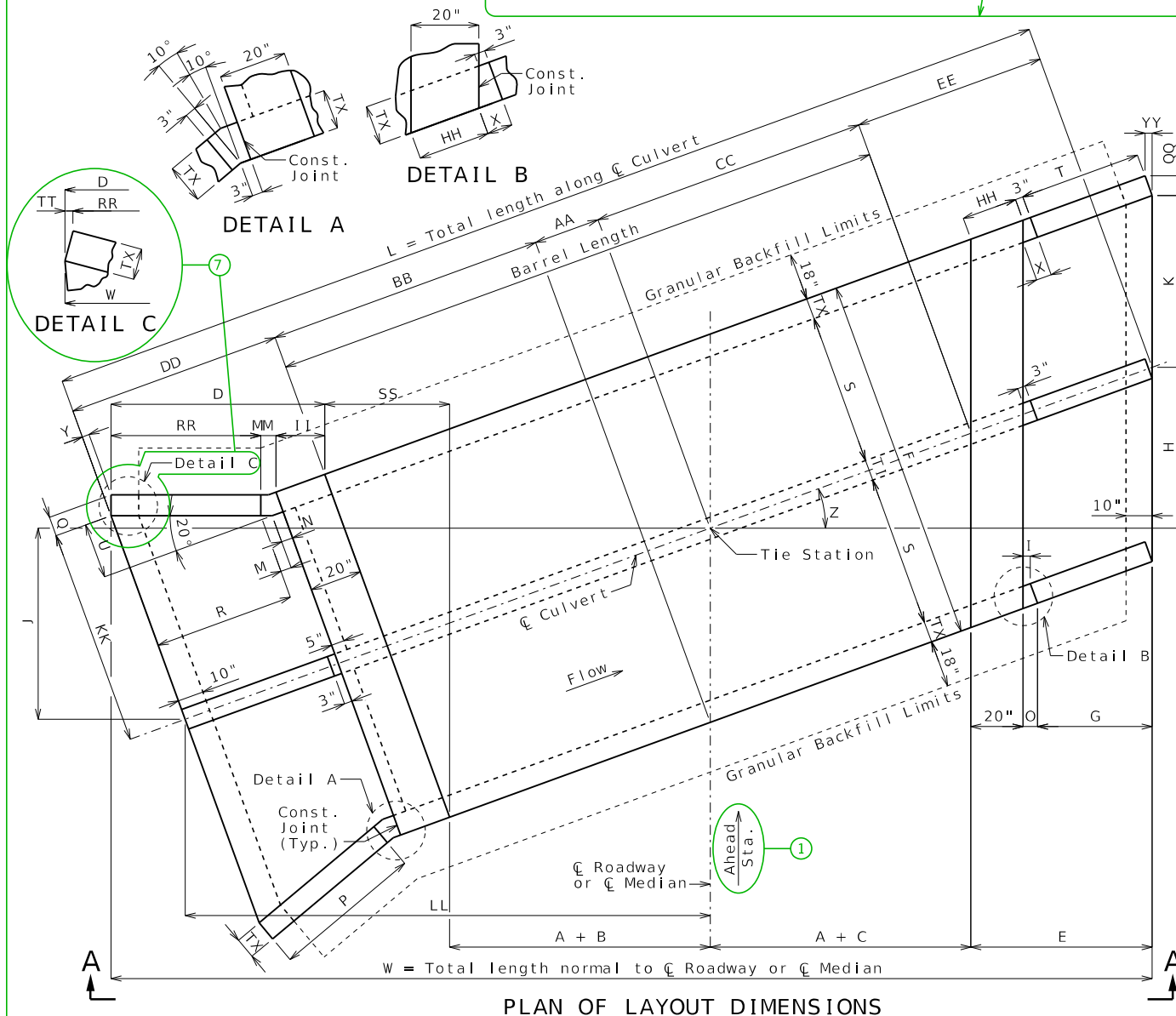

PLAN OF LAYOUT DIMENSIONS

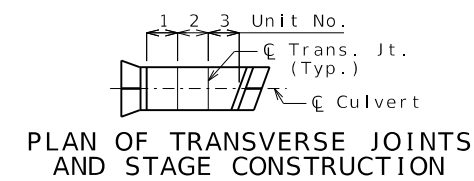

Remove if not applicable.

| Fill Heights          |    |
|-----------------------|----|
| ☐ Rdwy at ☐ Culvert = | ft |
| Design (Units 1 & ) = | ft |
| Design (Units & ) =   | ft |
| Design (Units & ) =   | ft |

Dimensions are based on end units, except AA is based on Unit . Fill heights are measured from the top of top slab to the top of earth fill or roadway.

| Estimated Quantities                       |          |   | Final |
|--|----------|---|-------|
| Class 4 Excavation                         | cu. yard | x |       |
| Temporary Shoring                          | lump sum | 1 |       |
| Partial Removal of Culvert-Bridge Concrete | lump sum | 1 |       |
| Class B-1 Concrete (Culverts-Bridge)       | cu. yard | x |       |
| Reinforcing Steel (Culverts-Bridge)        | pound    | x |       |

Alternate Estimated Quantities for Culvert Extensions or when Five Items are Required

LOCATION SKETCH

| Unit No. | Unit Length | Member Thickness |    |    |    |       | Top Slab Reinforcement |         |         |         |         |         | Bottom Slab Reinforcement |         |         |     |      |    | Wall Reinforcement |      |     |      |    |    |     |      |    |     |      |     |      |    |
|----------|-------------|------------------|----|----|----|-------|------------------------|---------|---------|---------|---------|---------|---------------------------|---------|---------|-----|------|----|--------------------|------|-----|------|----|----|-----|------|----|-----|------|-----|------|----|
|          |             | TS               | BS | TX | TI | F     | A1 Bars                | J3 Bars | H1 Bars | H2 Bars | A2 Bars | J4 Bars | H3 Bars                   | B1 Bars | B2 Bars |     |      |    |                    |      |     |      |    |    |     |      |    |     |      |     |      |    |
| x        | x           | x                | x  | x  | x  | ' - " | Sz.                    | Spa.    | Sz.     | Spa.    | C1      | K2      | Sz.                       | Spa.    | C5      | Sz. | Spa. | C6 | Sz.                | Spa. | Sz. | Spa. | C4 | K3 | Sz. | Spa. | C7 | Sz. | Spa. | Sz. | Spa. | G1 |
| x        | x           | x                | x  | x  | x  | ' - " | x                      | x       | x       | x       | x       | x       | x                         | x       | x       | x   | x    | x  | x                  | x    | x   | x    | x  | x  | x   | x    | x  | x   | x    | x   | x    |    |
| x        | x           | x                | x  | x  | x  | ' - " | x                      | x       | x       | x       | x       | x       | x                         | x       | x       | x   | x    | x  | x                  | x    | x   | x    | x  | x  | x   | x    | x  | x   | x    | x   | x    |    |

Substitute table for tables shown on Standard Plan 703.47