

BRIDGE APPROACH TRANSITION (EXTENDED CURB)(2)

GENERAL NOTES:

MGS GUARDRAIL SHALL BE TANGENTIAL WITH BRIDGE APPROACH TRANSITION FOR 12'-6" BEYOND THE TWO NESTED W-BEAM STIFFNESS TRANSITION AND 25'-0" BEYOND THRIE BEAM TRANSITION SECTION.

AT THE CONTRACTORS OPTION, A SINGLE 18'-9" PIECE OF THRIE BEAM MAY BE SUBSTITUTED FOR ONE OF THE 12'-6" PANELS AND THE 6'-3" SECTION AS SHOWN.

FOR PROTECTIVE COATING AND MATERIAL REQUIREMENTS, SEE SEC 1040 OF THE STANDARD SPECIFICATIONS.

RAIL POSTS SHALL BE SET PERPENDICULAR TO THE ROADWAY PROFILE GRADE AND VERTICALLY IN CROSS SECTION.

USE 5/8" BUTTON-HEAD OVAL SHOULDER BOLTS WITH HEX NUTS AT ALL SLOTS (THICKNESS OF HEX NUTS = 3/8" MIN.).

THE BEARING PLATE SHALL BE FABRICATED FROM GRADE A36 STEEL AND GALVANIZED.

ALL LAP SPLICES, INCLUDING END SHOES, SHALL BE MADE IN THE DIRECTION OF TRAFFIC.

THE COST OF FURNISHING, FABRICATING AND INSTALLING BRIDGE APPROACH TRANSITION (EXTENDED CURB), COMPLETE IN PLACE, WILL BE PAID FOR AT THE CONTRACT UNIT PRICE PER EACH.

THE CONTRACTOR MAY, AT THEIR OPTION, FURNISH EQUIVALENT SECTIONS FABRICATED FROM MATERIAL MEETING AND IN ACCORDANCE WITH THE REQUIREMENTS OF ASTM A769 GRADE 36 OR 40. THE SECTIONS SHALL BE GALVANIZED AFTER FABRICATION IN ACCORDANCE WITH REQUIREMENTS OF AASHTO M 111.

- (1) PLACE THE FIRST POST OF THE MGS 6'-3" PAST THE LAST POST OF THE BRIDGE APPROACH TRANSITION TO KEEP POSTS OFFSET FROM THE RAIL SPLICES.
- (2) WHERE CURB EXTENDS UPSTREAM OF POST NO. (11) FOR DRAINAGE PURPOSES, A STIFFNESS TRANSITION CONSISTING OF AN EXTRA 12'-6" BEAM OF 12 GAUGE W-BEAM MUST BE NESTED PRIOR TO THE TRANSITION SECTION (UPSTREAM OF POST NO. (13)). THE CURB SHALL BE EXTENDED TO THE END OF THE 12'-6" 12 GAUGE W-BEAM STIFFNESS TRANSITION SEE STD. PLAN 609.40 FOR DETAILS. WHEN CURBS DO NOT EXTEND UPSTREAM OF POST NO. (11), PAY FOR A BRIDGE APPROACH TRANSITION (REGULAR CURB/NO CURB). FOR DETAILS OF BRIDGE APPROACH TRANSITION (REGULAR CURB/NO CURB), SEE SHEET 2 OF 6.
- (3) THE ADDITIONAL REQUIRED MGS GUARDRAIL IS INCLUDED IN THE TOTAL LENGTH OF NEED AND SHALL BE PAID FOR AS A GUARDRAIL PAY ITEM.

	MISSOURI HIGHWAYS AND TRANSPORTATION COMMISSION 105 WEST CAPITOL JEFFERSON CITY, MO 65102 1-888-ASK-MODOT (1-888-275-6636)	
		MIDWEST GUARDRAIL SYSTEM (MGS) VERTICAL BARRIER TRANSITIONS
DATE EFFECTIVE: 07/01/2021 DATE PREPARED: 4/29/2021	606.60B	SHEET NO. 1 OF 6

IF A SEAL IS PRESENT ON THIS SHEET IT HAS BEEN ELECTRONICALLY SEALED AND DATED.

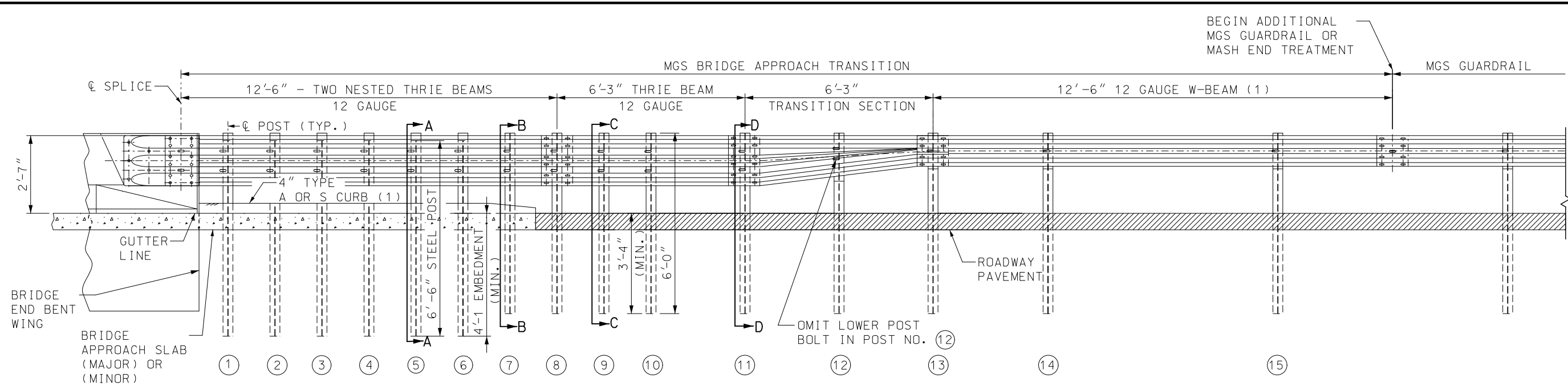

BRIDGE APPROACH TRANSITION (WITH REGULAR LENGTH CURB OR NO CURB)(1)

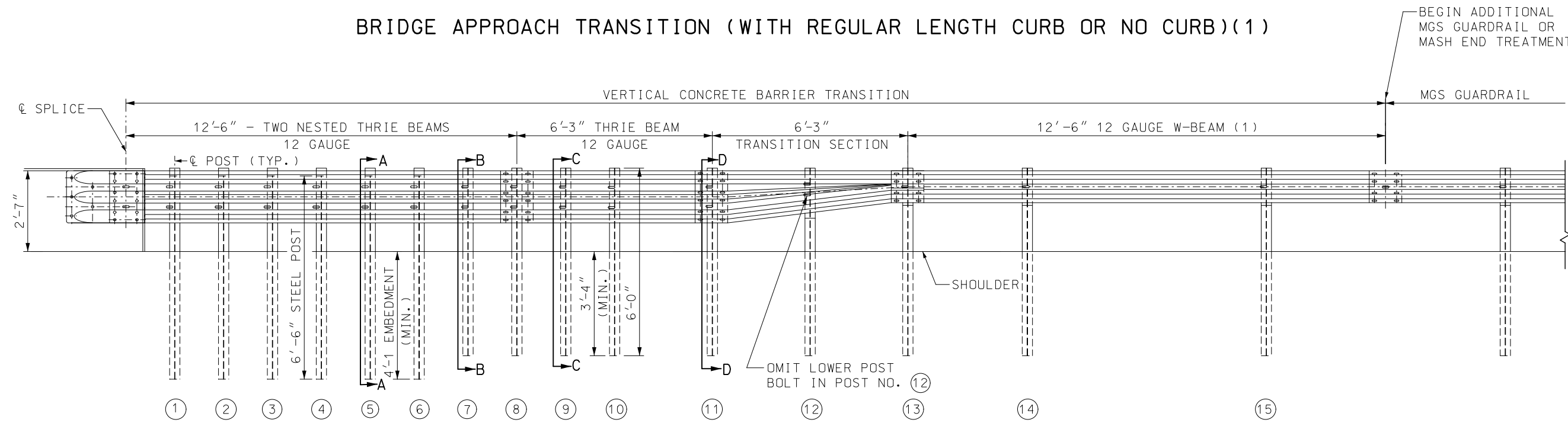

VERTICAL CONCRETE BARRIER TRANSITION (REGULAR LENGTH CURB OR NO CURB)(1)
(VIEW SHOWN WITHOUT CURB)

GENERAL NOTES:
SEE SHEET 1 FOR ADDITIONAL NOTES NOT INCLUDED ON THIS SHEET.

THE COST OF FURNISHING, FABRICATING AND INSTALLING
BRIDGE APPROACH TRANSITION (REGULAR/NO CURB), COMPLETE
IN PLACE, WILL BE PAID FOR AT THE CONTRACT UNIT
PRICE PER EACH.

(1) WHERE CURB EXTENDS UPSTREAM OF POST NO. (11) FOR DRAINAGE PURPOSES,
A STIFFNESS TRANSITION CONSISTING OF AN EXTRA 12'-6" BEAM OF 12
GAUGE W-BEAM MUST BE NESTED PRIOR TO THE TRANSITION SECTION
(UPSTREAM OF POST NO. (13)). THE CURB SHALL BE EXTENDED TO THE END
OF THE 12'-6" 12 GAUGE W-BEAM STIFFNESS TRANSITION SEE STD. PLAN
609.40 FOR DETAILS. IF CURB EXTENDS BEYOND POST NO. (11), PAY FOR
A BRIDGE APPROACH TRANSITION (EXTENDED CURB).

BEGIN ADDITIONAL
MGS GUARDRAIL OR
MASH END TREATMENT

MGS GUARDRAIL

BEGIN ADDITIONAL
MGS GUARDRAIL OR
MASH END TREATMENT

MGS GUARDRAIL

	MISSOURI HIGHWAYS AND TRANSPORTATION COMMISSION 105 WEST CAPITOL JEFFERSON CITY, MO 65102 1-888-ASK-MODOT (1-888-275-6636)	
		MIDWEST GUARDRAIL SYSTEM (MGS) VERTICAL BARRIER TRANSITIONS
DATE EFFECTIVE: 07/01/2021 DATE PREPARED: 5/5/2021	606.60B	SHEET NO. 2 OF 6

IF A SEAL IS PRESENT ON THIS SHEET IT HAS BEEN ELECTRONICALLY SEALED AND DATED.

SET BLOCK
3" ABOVE
STEEL POST

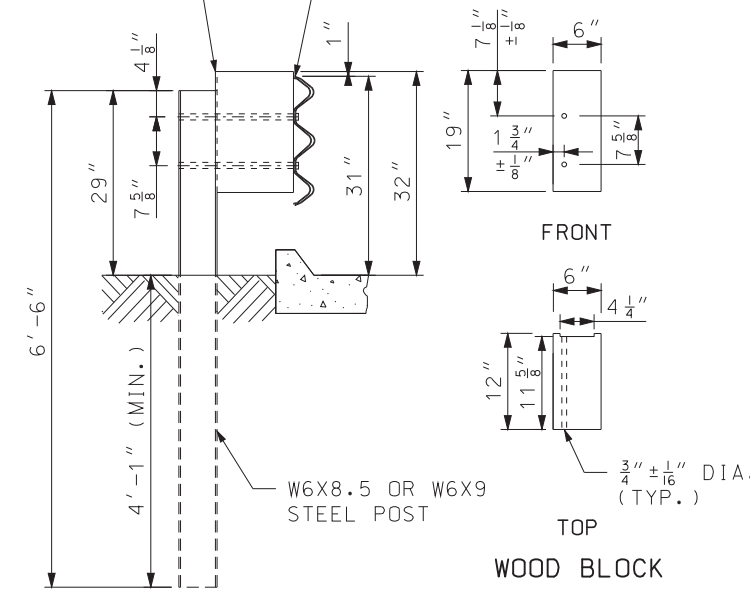

SECTION A-A

TWO NESTED 12 GAUGE
THRIE BEAM

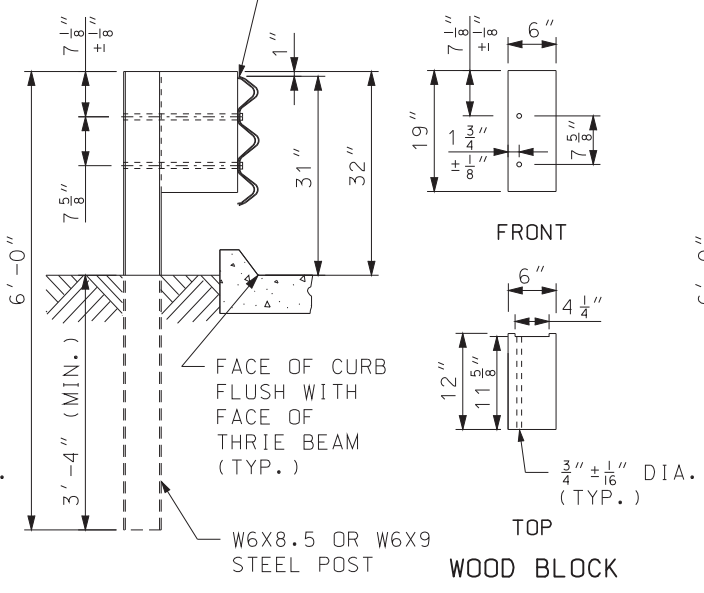

SECTION B-B

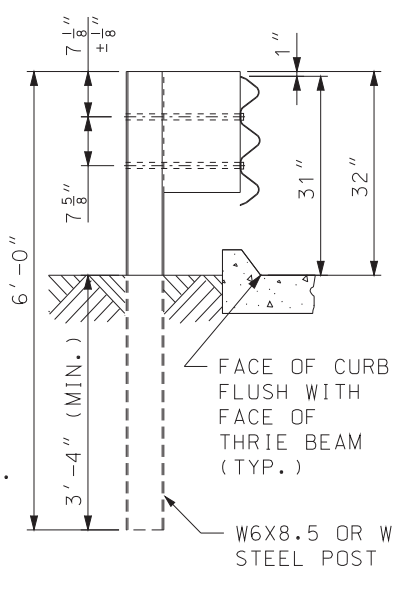

SECTION C-C

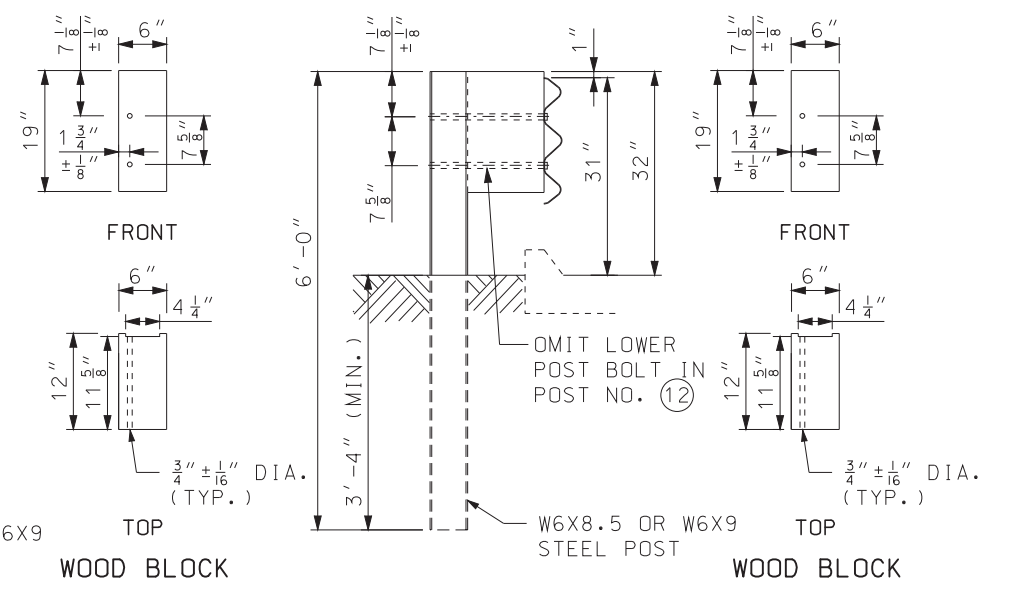

SECTION D-D

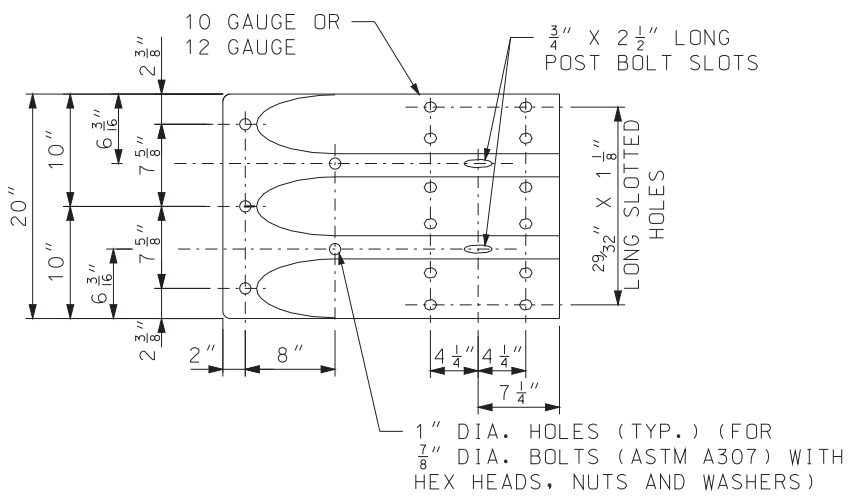

TERMINAL CONNECTOR

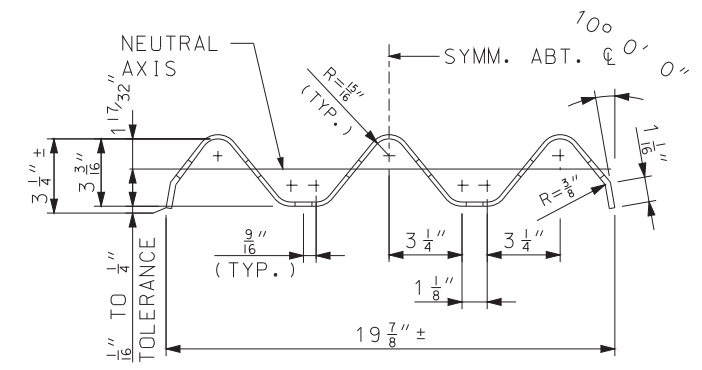

SECTION THROUGH THRIE BEAM RAIL

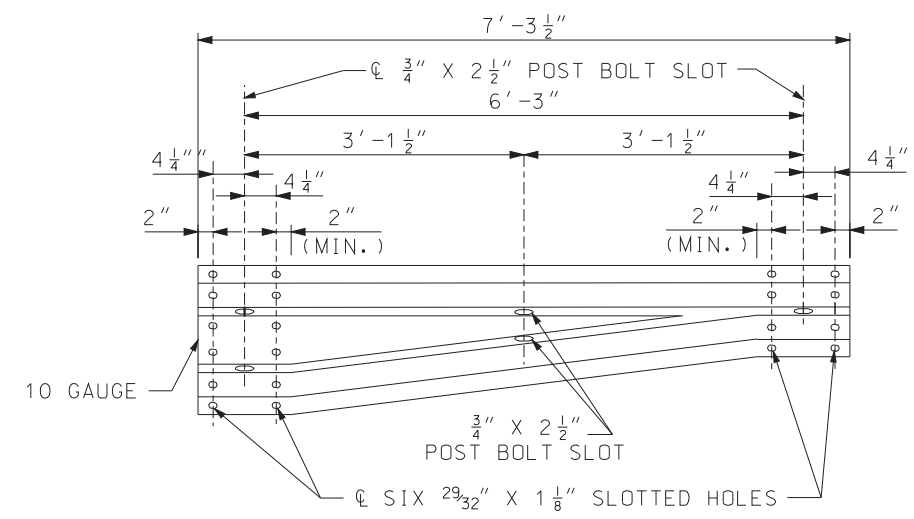

TRANSITION SECTION

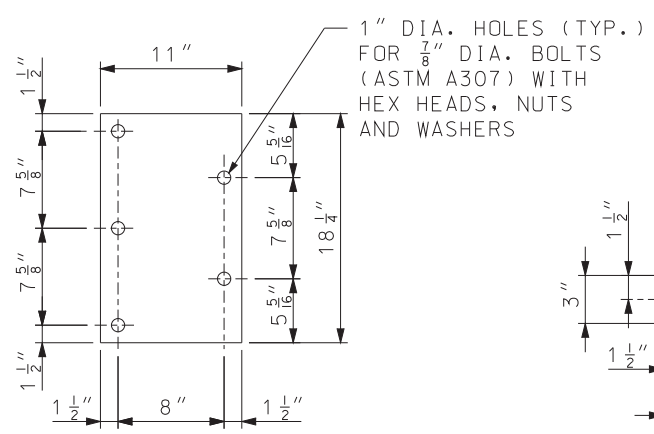

5/8" BEARING PLATE

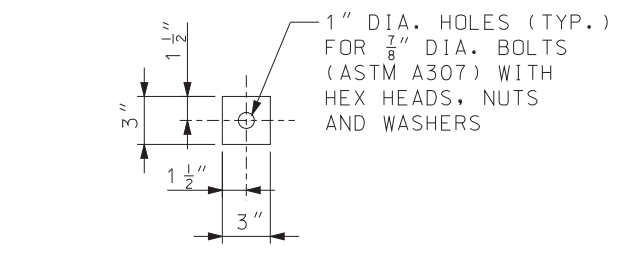

OPTIONAL 5/8" BEARING PLATE
(5 REQUIRED)

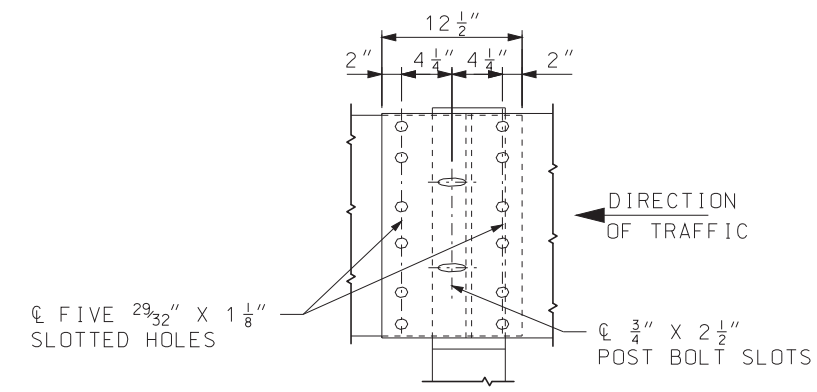

THRIE BEAM RAIL SPLICE AT POST

<p>MISSOURI HIGHWAYS AND TRANSPORTATION COMMISSION</p> <p>105 WEST CAPITOL JEFFERSON CITY, MO 65102 1-888-ASK-MODOT (1-888-275-6636)</p>	
	<p>MIDWEST GUARDRAIL SYSTEM (MGS)</p> <p>VERTICAL BARRIER TRANSITIONS</p>
<p>DATE EFFECTIVE: 07/01/2017 DATE PREPARED: 5/1/2017</p>	<p>606.60B</p>
<p>SHEET NO. 3 OF 6</p>	

IF A SEAL IS PRESENT ON THIS SHEET IT HAS BEEN ELECTRONICALLY SEALED AND DATED.

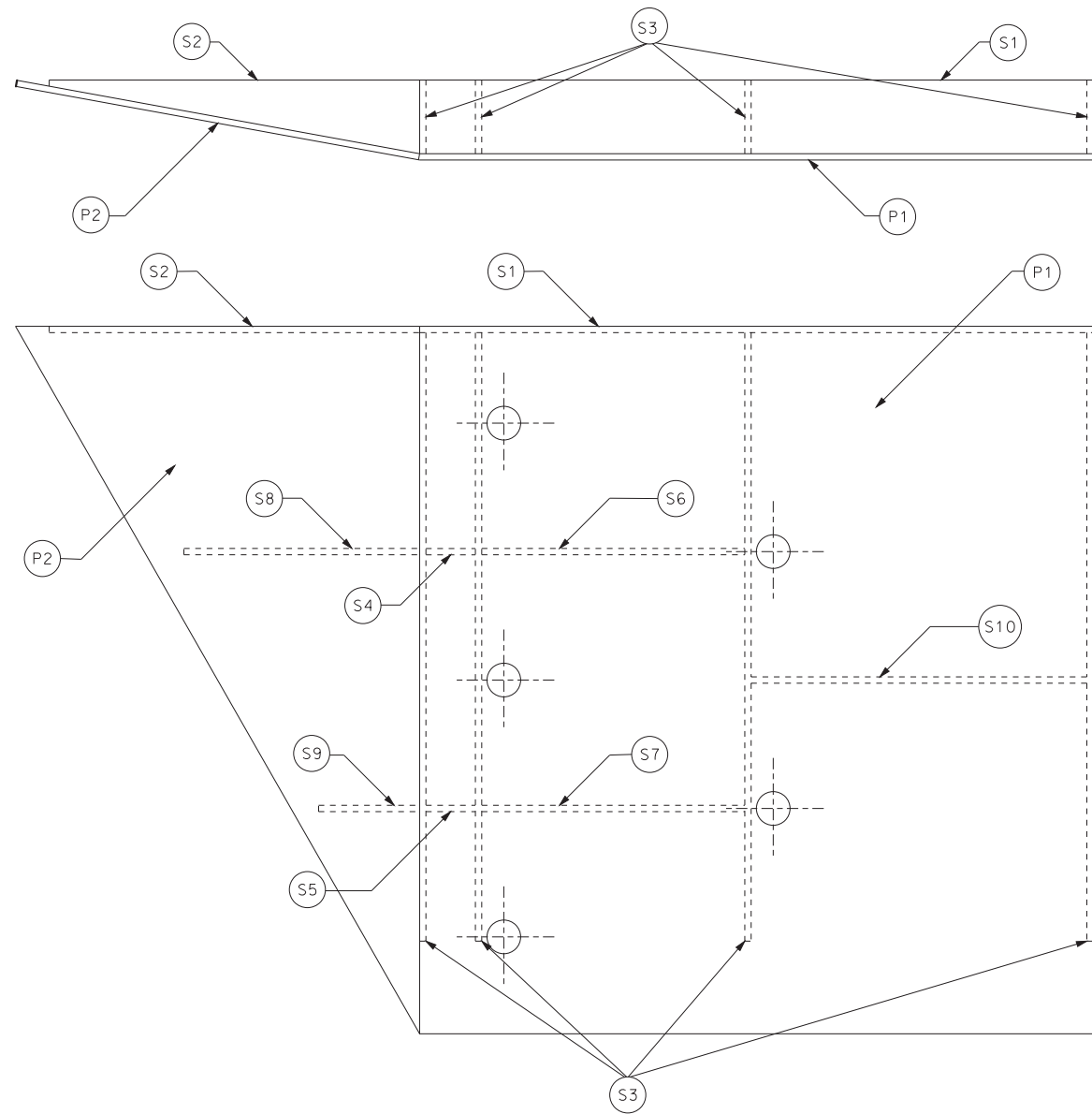
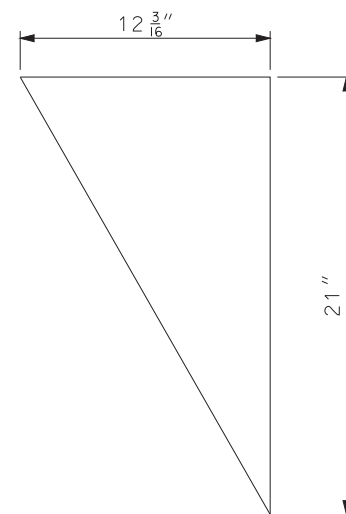
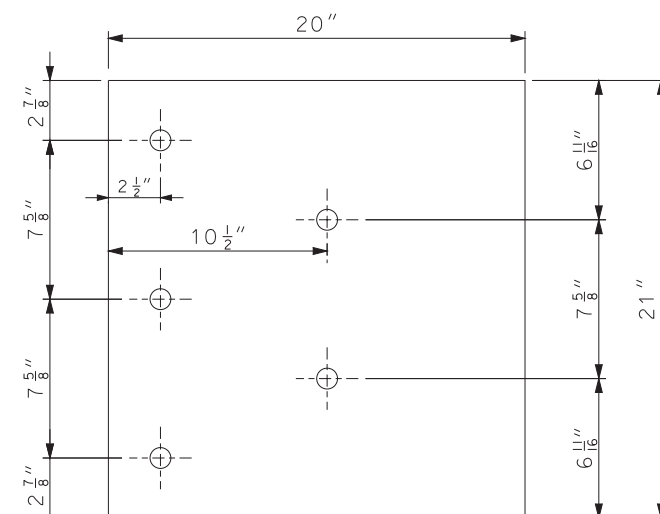

PLATE AND STIFFENER IDENTIFICATION



(P2) COVER PLATE #2



(P1) COVER PLATE #1

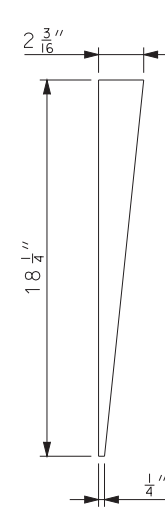

(S3) STIFFENER #3: 4 EACH

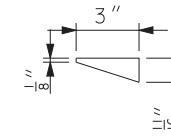

(S9) STIFFENER #9: 1 EACH

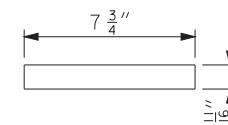

(S7) STIFFENER #7: 1 EACH

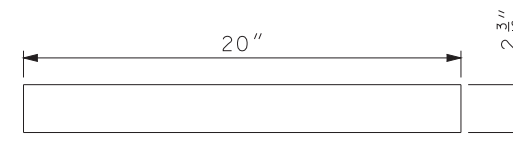

(S1) STIFFENER #1: 1 EACH

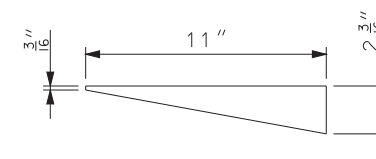

(S2) STIFFENER #2: 1 EACH

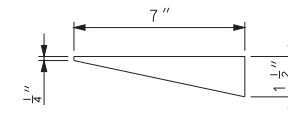

(S8) STIFFENER #8: 1 EACH

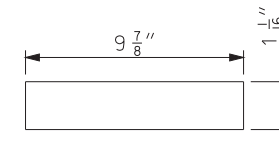

(S10) STIFFENER #10: 1 EACH

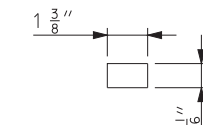

(S5) STIFFENER #5: 1 EACH

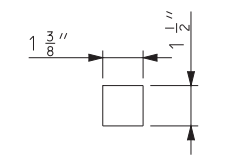

(S4) STIFFENER #4: 1 EACH

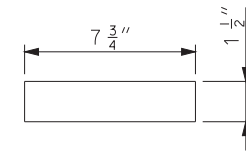

(S6) STIFFENER #6: 1 EACH

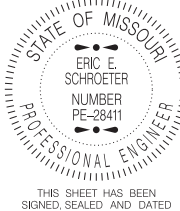
 MISSOURI HIGHWAYS AND TRANSPORTATION COMMISSION 105 WEST CAPITOL JEFFERSON CITY, MO 65102 1-888-ASK-MODOT (1-888-275-6636)	
	MIDWEST GUARDRAIL SYSTEM (MGS) VERTICAL BARRIER TRANSITIONS (CONNECTOR PLATE DETAIL)
DATE EFFECTIVE: 07/01/2017 DATE PREPARED: 5/1/2017	SHEET NO. 606.60B 4 OF 6

IF A SEAL IS PRESENT ON THIS SHEET IT HAS BEEN ELECTRONICALLY SEALED AND DATED.

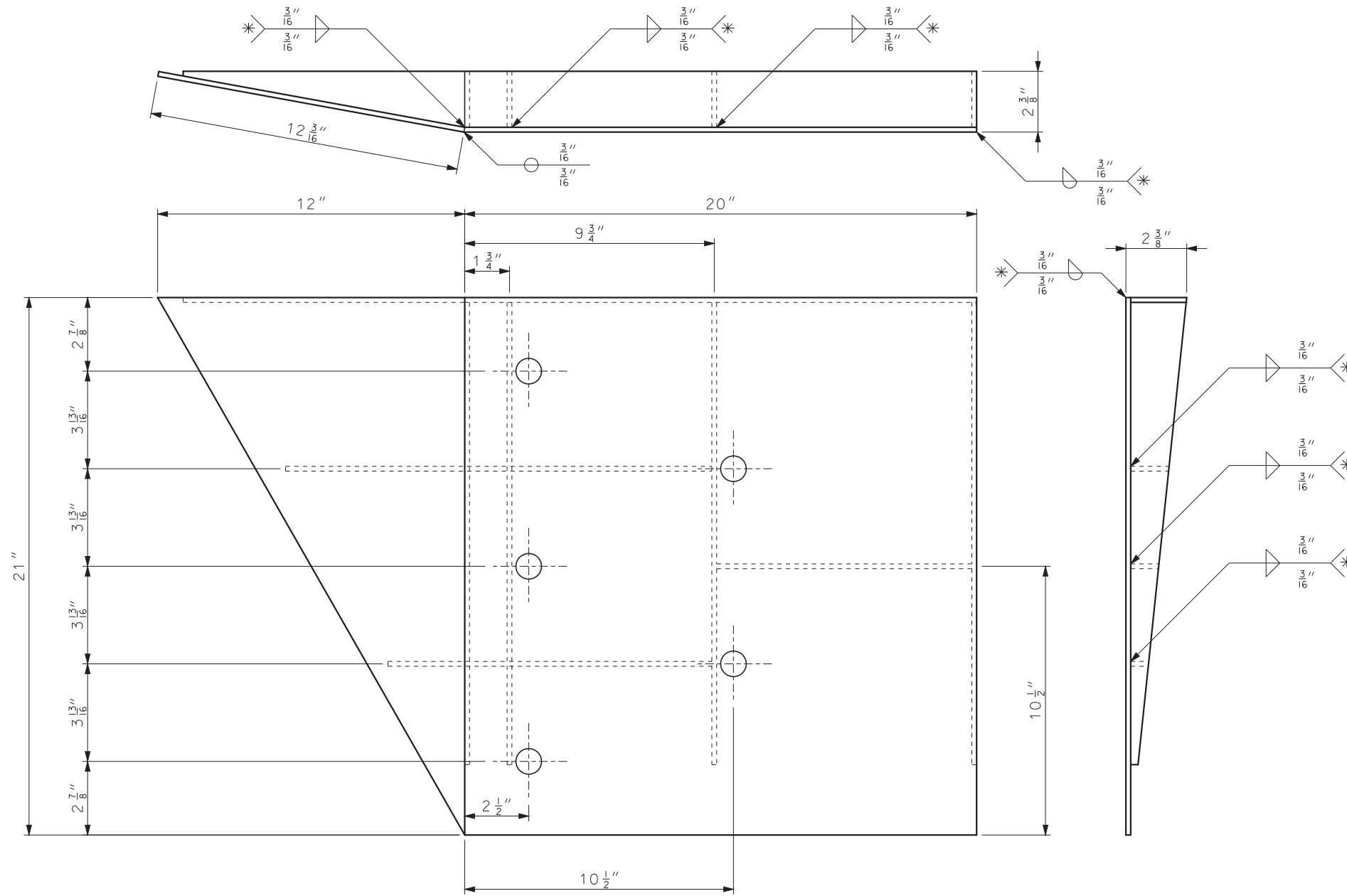

WELDING INSTRUCTION

* ALL FILLET WELDS SHALL BE 1" LONG SPACED AT 2".

GENERAL NOTES:

COVER PLATE PANELS ARE $\frac{3}{16}$ " THICK.

ALL STIFFENERS ARE $\frac{1}{4}$ " THICK.

CONNECTOR PLATE SHALL BE FABRICATED FROM ASTM GRADE A36 STEEL AND GALVANIZED.

FOR GALVANIZED REQUIREMENTS, SEE SECTION 1040 OF THE STANDARD SPECIFICATIONS.

ALL HOLE DIAMETERS SHALL BE 1".

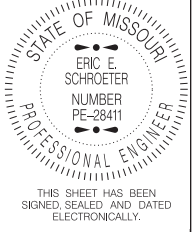
 MISSOURI HIGHWAYS AND TRANSPORTATION COMMISSION 105 WEST CAPITOL JEFFERSON CITY, MO 65102 1-888-ASK-MODOT (1-888-275-6636)	
	MIDWEST GUARDRAIL SYSTEM (MGS) VERTICAL BARRIER TRANSITIONS (CONNECTOR PLATE DETAIL)
DATE EFFECTIVE: 07/01/2017 DATE PREPARED: 5/1/2017	SHEET NO. 606.60B 5 OF 6

IF A SEAL IS PRESENT ON THIS SHEET IT HAS BEEN ELECTRONICALLY SEALED AND DATED.

IF A SEAL IS PRESENT ON THIS SHEET IT HAS BEEN ELECTRONICALLY SEALED AND DATED.

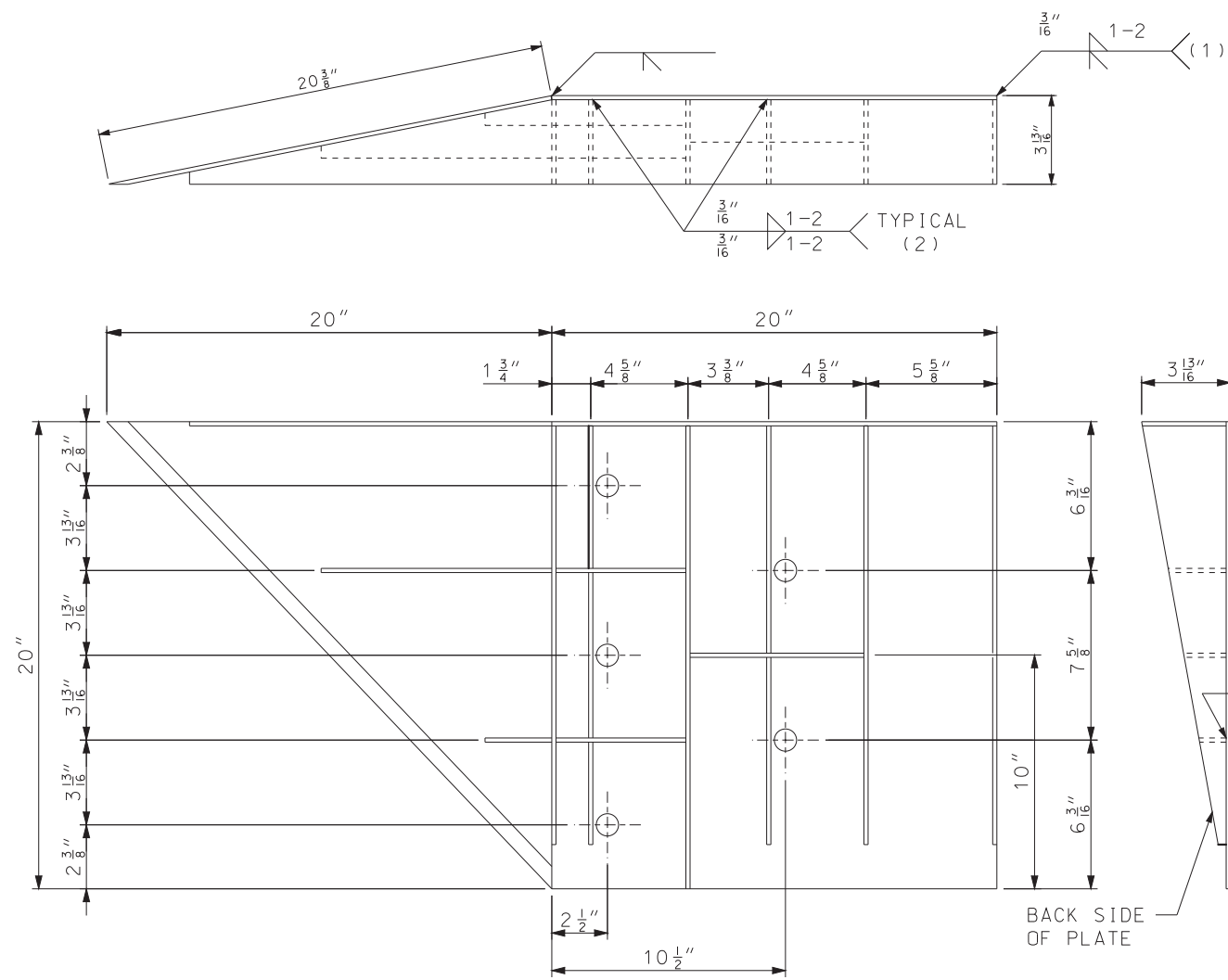

WELDING INSTRUCTION
(VIEWED FROM BACK SIDE OF PLATE)

- (1) STIFFENERS LOCATED AT THE OUTSIDE EDGES OF THE COVER PLATES SHALL BE WELDED AS FOLLOWS:
SINGLE BEVEL GROOVE WELD ON EXTERNAL SIDES AND $\frac{3}{16}$ " FILLET WELD BY 1" LONG SPACED AT 2" ON INTERNAL SIDES.
- (2) STEFFENERS LOCATED ON THE INSIDE OF THE COVER PLATE SHALL BE WELDED AS FOLLOWS:
 $\frac{3}{16}$ " FILLET WELD BY 1" LONG SPACED AT 2".

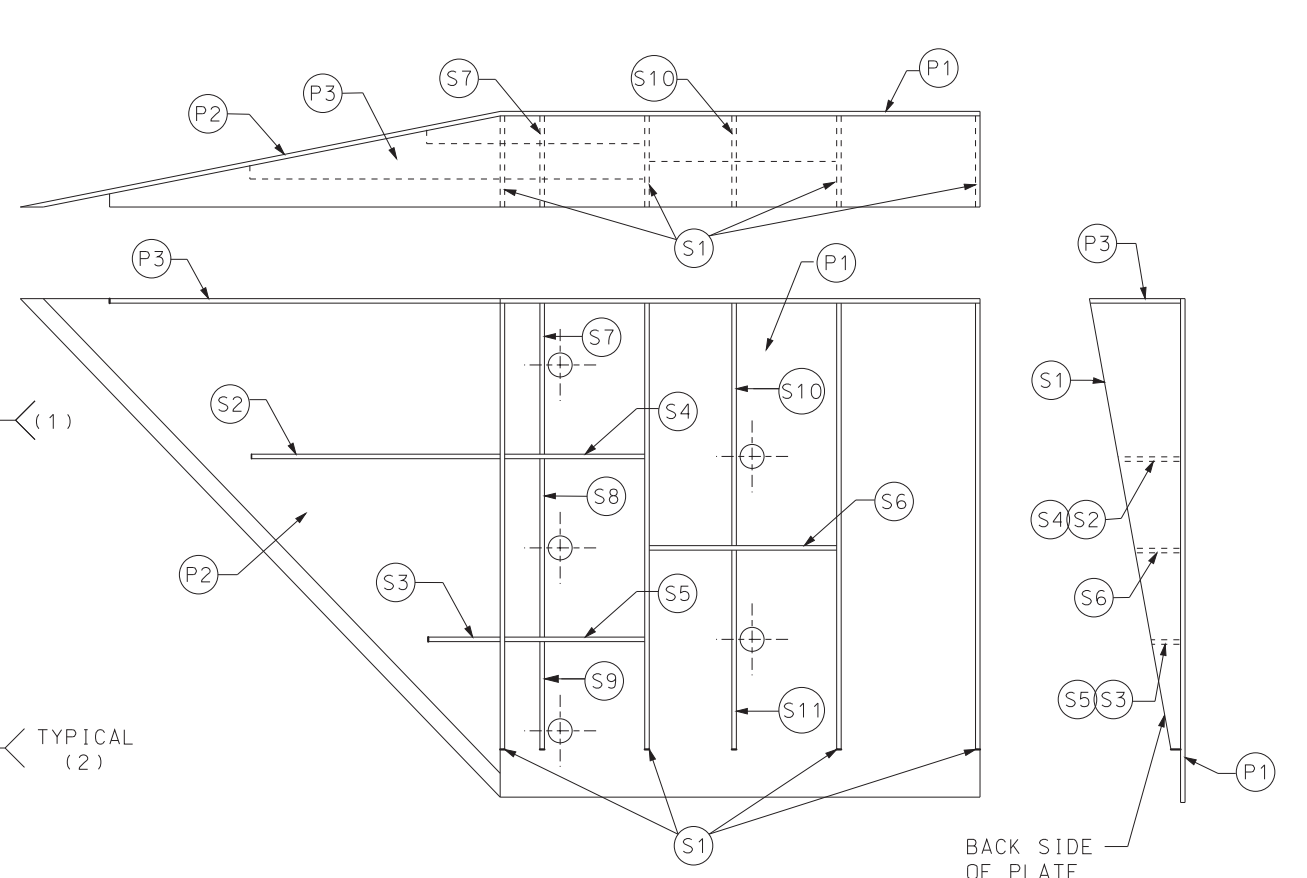

PLATE AND STIFFENER IDENTIFICATION
(VIEWED FROM BACK SIDE OF PLATE)

CONNECTOR PLATE DIMENSION (PER ASSEMBLY)				
PLATE	QUANTITY	SHAPE	SIZE (A x B x C x D)	THICKNESS
P1	1		20" x 20"	$\frac{3}{16}$ "
P2	1		20" x 20" x 28 $\frac{3}{16}$ "	$\frac{3}{16}$ "
P3	1		39" x 3 $\frac{5}{8}$ " x 20" x 19 $\frac{5}{16}$ "	$\frac{3}{16}$ "
S1	4		18 $\frac{7}{16}$ " x 3 $\frac{5}{8}$ " x 18 $\frac{3}{4}$ "	$\frac{1}{4}$ "
S2	1		10 $\frac{1}{4}$ " x 2 $\frac{7}{16}$ " x 10 $\frac{3}{8}$ " x $\frac{1}{2}$ "	$\frac{1}{4}$ "
S3	1		3" x 1 $\frac{1}{16}$ " x 3 $\frac{1}{8}$ " x $\frac{1}{2}$ "	$\frac{1}{4}$ "
S4	1		6 $\frac{1}{8}$ " x 2 $\frac{7}{16}$ "	$\frac{1}{4}$ "
S5	1		6 $\frac{1}{8}$ " x 1 $\frac{1}{16}$ "	$\frac{1}{4}$ "
S6	1		7 $\frac{3}{4}$ " x 1 $\frac{3}{4}$ "	$\frac{1}{4}$ "
S7	1		2 $\frac{3}{16}$ " x 6" x 3 $\frac{5}{8}$ " x 5 $\frac{7}{8}$ "	$\frac{1}{4}$ "
S8	1		1 $\frac{5}{32}$ " x 7 $\frac{1}{2}$ " x 2 $\frac{1}{2}$ " x 7 $\frac{3}{8}$ "	$\frac{1}{4}$ "
S9	1		6 $\frac{1}{16}$ " x 6 $\frac{3}{16}$ " x 1 $\frac{3}{32}$ "	$\frac{1}{4}$ "
S10	1		1 $\frac{7}{8}$ " x 9 $\frac{7}{8}$ " x 3 $\frac{5}{8}$ " x 9 $\frac{11}{16}$ "	$\frac{1}{4}$ "
S11	1		8 $\frac{1}{2}$ " x 8 $\frac{3}{4}$ " x 1 $\frac{13}{16}$ "	$\frac{1}{4}$ "

GENERAL NOTES:

- COVER PLATE PANELS ARE $\frac{3}{16}$ " THICK.
- ALL STIFFENERS ARE $\frac{1}{4}$ " THICK.
- CONNECTOR PLATE SHALL BE FABRICATED FROM ASTM GRADE A36 STEEL AND GALVANIZED.
- FOR GALVANIZED REQUIREMENTS, SEE SEC 1040 OF THE STANDARD SPECIFICATIONS.
- ALL HOLE DIAMETERS SHALL BE 1".

MISSOURI HIGHWAYS AND TRANSPORTATION COMMISSION

105 WEST CAPITOL
JEFFERSON CITY, MO 65102
1-888-ASK-MODOT (1-888-275-6636)

MIDWEST GUARDRAIL SYSTEM (MGS)

VERTICAL BARRIER TRANSITIONS

(CONNECTOR PLATE DETAIL)

SINGLE SLOPE BARRIERS

THIS SHEET HAS BEEN SIGNED, SEALED AND DATED ELECTRONICALLY.

DATE EFFECTIVE: 07/01/2017

DATE PREPARED: 5/1/2017

SHEET NO.

6 OF 6