

2025 Edition



# CONCRETE FIELD

Includes Advanced Concrete





# COURSE CONTENT

## CONCRETE FIELD

**MoDOT TM20** Measurement of Air, Surface, or Asphalt Mixture Temperature

**AASHTO R60** Sampling Freshly Mixed Concrete  
ASTM C172

**ASTM C1064** Temperature of Freshly Mixed Hydraulic-Cement Concrete

**AASHTO T119** Test for Slump of Hydraulic Cement Concrete  
ASTM C143

**AASHTO T152** Test for Air Content of Freshly Mixed Concrete by the (Pressure)  
ASTM C231 Method

**AASHTO R100** Making and Curing of Concrete Specimens in the Field ASTM C31

**AASHTO T121M** Density (Unit Weight), Yield, and Air Content (Gravimetric) of Concrete  
ASTM C138

**AASHTO T196M** Air content of Freshly Mixed Concrete by the (Volumetric) Method  
ASTM C173

**APPENDIX**

**GLOSSARY**

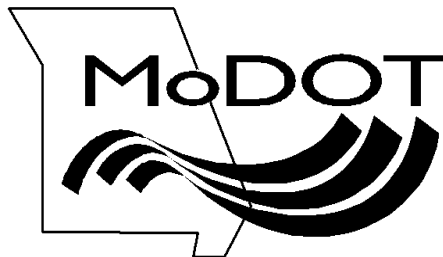





# Concrete Field

## Updates

### 2025 – Updates

- **AASHTO T152**
  - Equipment: For 14L measures the rubber or rawhide mallet head now weighs 0.60 ± 0.25kg, and for smaller measures the mallet now weighs 1.02 ± 0.23 kg.
  - Equipment: Meter Type B working pressures is now 50 to 205 Kpa.

### 2024 – Updates

- **MODOT TM20** – No updates
- **AASHTO R60**
  - Added Continuous Mixer section.
- **AASHTO T119**
  - Equipment: Mold must be free from dents, deformations, or adhered mortar.
  - Procedure: 1<sup>st</sup> layer of rodding added: Rod the bottom layer through its depth.
- **AASHTO T152**
  - Equipment: Can use a plastic wash bottle to add water to the meter.
- **AASHTO T100**
  - Acceptance testing for strength, perform the following tests for each sample of concrete from which specimens are made. (Slump, Air Content, and Temperature).
- **AASHTO T121M**

Pints of Alcohol	Ounces of Alcohol	Liters of Alcohol	Correction (subtract) <sup>a</sup>
≤ 2.0	≤ 32	≤ 1.0	0.00 <sup>b</sup>
3.0	48	1.5	0.25
4.0	64	2.0	0.50
5.0	80	2.5	0.75

- **New Table 1:**
- Calibrated Cup = Standardized Cup
- Bowl = Measuring Bowl
- Calculation section updated, and added a formula:

$$A = A_R - C + W$$

## 2023 – Updates

- **AASHTO T196:**

- **Water for the meter:** The thermometer for measuring the temperature of the water for the meter shall meet the requirements of M 339M/M 339 with a temperature range of at least 19 to 23.5°C (66.4 to 74.6°F) and an accuracy of ±0.5°C (±0.9°F) (see note 3),
  - NOTE 3: Thermometer types to use include:
    - ASTM E1 Mercury Thermometer that is submerged to its required immersion depth.
    - ASTM E2877 digital metal stem thermometer
    - ASTM E230/E 230M thermocouple thermometer, Type T, Special.

## 2022 – Updates

- **Removed Videos from most methods.**
- Added Advanced Concrete to the Manual, Exams, and Proficiency exam.
- One method update AASHTO T23 is now renamed to **AASHTO R100**
  - Changed under scope, the word “method” to “Practice”.
  - Changed Table for Tamping Rod Requirements for length of rod from 650 (26) to 600 (24).

## 2021 – Updates

- **Added Videos to all methods.**
- **Method updates for 2021:**
  - Method AASHTO T23: changed information on consolidation of cylindrical molds. When using reusable plastic molds, you can use a mallet to tap the outside, for one-time disposable molds that can be damaged with using a mallet, use an open hand to tap the outside of the mold.
- **AASHTO T 121**
  - One update on equipment: **Internal Vibrator**
    - Internal Vibrator: The vibrator frequency shall be at least 9000 vibrations per min (150HZ) while the vibrator is operating in concrete. The outside diameter of a round vibrator shall be at least 19mm (0.75in) and not greater than 38mm (1.50in). Other shaped vibrator shall have a perimeter equivalent to the circumference of an appropriate round vibrator. The combined length of the vibrator shaft and vibrating element shall exceed the depth of the section being vibrated by at least 75 mm (3in.). The vibrator frequency shall be checked periodically.

# **MoDOT TM20**

## **Measurement of Air, Surface, or Asphalt Mixture Temperature**

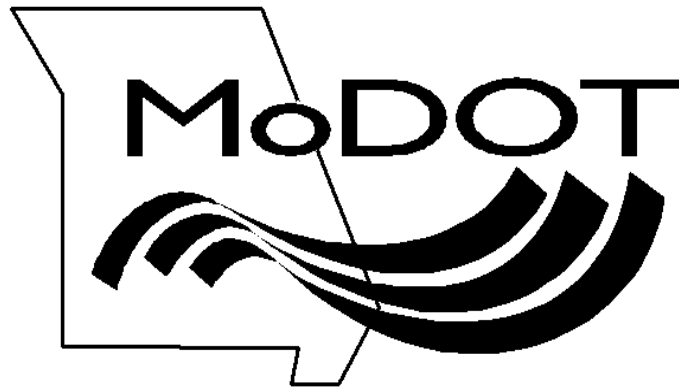



## Required Audits

**All testers** on Federal-Aid Projects (MoDOT or Off-System) are required by the FHWA to be audited at least once per year.

### Reasons:

- To ensure proper test procedures are being utilized.
- To ensure testing equipment is calibrated and operating properly.
- **Types of Audits;** procedure or comparison.
- **Be Proactive;** schedule your audit as early as possible with MoDOT Materials in district offices, do NOT wait until the end of the year.
- **Provide Proof;** when audited, present a MoDOT Certification Card, or a MoDOT Letter.

---

---

---

---

---

---

---

---

1

## MoDOT TM20

Measurement of Air, Surface, or Asphalt Mixture Temperature

2

05/13/2021

---

---

---

---

---

---

---

---

2

## WHY IS TEMPERATURE IMPORTANT?

- The temperature is required of many AASHTO specifications in testing of asphalt materials as well as concrete.
- Temperature is used to provide quality assurance and to prevent early pavement deterioration.

3

---

---

---

---

---

---

---

---

3



### EQUIPMENT CALIBRATION

- Calibrate thermometers **annually**.
- Calibration of a thermometer will establish a **correction factor** to adjust the thermometer reading to the true temperature.
- Information on how MoDOT owned thermometers are verified may be obtained from the District Materials Staff.
- Thermometers can be sent to the manufacturer on a yearly basis to be verified/calibrated.

4

---

---

---

---

---

---

---

---

4

A Record of calibration/verification that is traceable to **National Institute of Standards and Technology (NIST) Traceable Standards** is needed for thermometers. Keep a copy of this record in the Laboratory's Quality Control Manual.



5

---

---

---

---

---

---

---

---

5

### Infrared Thermometer

Surface, Asphalt Mixture  
Range: 20° F to 400° F  
Increment: 2° F



6

---

---

---

---

---

---

---

---

6

### Mercury Thermometer

Air and Surface  
Range: 20° F to 130° F  
Increment: 2° F

**Note:** Mercury Thermometers are **rarely** used due to the potential of mercury contamination, if broken. Today technicians are using digital type thermometers with a metal probe.

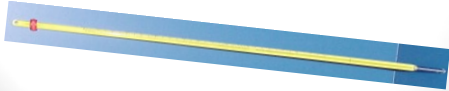

7

---

---

---

---

---

---

---

---

7

### Digital Thermometers

Air, Surface, Asphalt Mixture  
Range: 0°F to 400°F,  
Increment: 1°F  
NIST Traceable



8

---

---

---

---

---

---

---

---

8

### Max-Min Thermometer

Air, Surface  
Range: 20° F to 130° F  
Increment: 2° F



9

---

---

---

---

---

---

---

---

9

**Spot Check Disc Thermometer**

Surface  
Range: 32° F to 250° F  
Increment: 2° F

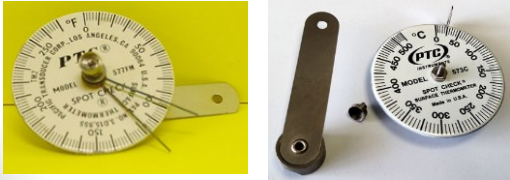

10

---

---

---

---

---

---

---

---

10

**BI-Therm Dial Thermometer**

Asphalt Mixture  
Range: 50° F to 400° F  
Increment: 5° F



11

---

---

---

---

---

---

---

---

11

**Armored Thermometer**

Asphalt Mixture  
Range: 50° F to 400° F  
Increment: 5° F



12

---

---

---

---

---

---

---

---

12

## Wooden Box

Surface

See EPG Test Method [TM20](#) for dimensions.  
(included in EPG at the end of this section)

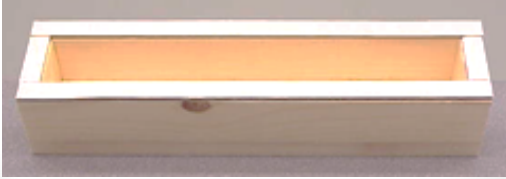

13

13

---

---

---

---

---

---

---

---

## PRECAUTIONS

- Do not use BI-Therm Dial thermometer (poker) for surface or air temperature.
- Infrared thermometers are for surface or asphalt mixture temperature only.
- Do not check surface temperature of asphalt immediately after roller has passed.
- Always check surface temperatures on a stationary target.

14

14

---

---

---

---

---

---

---

---

## PROCEDURE

### **Air Temperature**

- Thermometers: Mercury, Digital, Max-Min
- Location:
  - Shaded area  
(Not exposed to direct sunlight).
  - Safe area
- Position: 4.5 ft. above the surface
- **Report to nearest 2°F**

15

15

---

---

---

---

---

---

---

---

## Surface Temperature

- Infrared Thermometer
  - Follow the manufacturer's recommendations
- Spot Check Disc Thermometer
  - Place on surface
  - Read when needle stops moving
  - Report to nearest 2°F

Procedure

16

---

---

---

---

---

---

---

---

16

## Surface Temperature (continued)

- Max-Min or Mercury Thermometer
  - Place thermometer on surface
  - Place wooden box over top (open side down covering thermometer)
  - Leave thermometer under box for a minimum of 5 minutes
  - Lift the box enough to read the temperature. Report to nearest 2°F



Procedure

17

---

---

---

---

---

---

---

---

17

## Asphalt Mixture Temperature

- Digital, Armored or BI-Therm Dial Thermometer
  - Place stem in loose asphalt mixture.
  - Do not disturb until reading has stabilized.
  - Read temperature.
  - Report to nearest 5°F



Procedure

18

---

---

---

---

---

---

---

---

18



**Asphalt Mixture Temperature**  
(continued)

- Infrared Thermometer
  - Follow manufacturers instructions.
  - Direct reading of asphalt loose mix located in truck, a receiving hopper, or material at the end of paver augers.
  - Read temperature. **Report to nearest 5°F**



Procedure

19

---

---

---

---

---

---

---

---

19

DOCUMENTATION

- Read and record the air, surface or asphalt mixture temperature to the accuracy listed below in a bound field book.
  - Air, nearest 2° F
  - Surface, nearest 2° F
  - Asphalt Mixture, nearest 5° F

20

---

---

---

---

---

---

---

---

20



# MoDOT TM20: Measurement of Air, Surface and Asphalt Mixture Temperature PROFICIENCY CHECKLIST

Applicant: \_\_\_\_\_

Employer: \_\_\_\_\_

Trial #	1	2
Certificates or Report of Verification of Accuracy (Annual calibration) available?		
<b>AIR</b>		
1. Pick correct thermometer		
2. Location <ul style="list-style-type: none"> <li>- <i>Mercury, Digital, Max-Min thermometers</i></li> <li>- shade, no direct sunlight</li> <li>- position 4.5 feet above surface</li> <li>- safe location</li> </ul>		
3. Document to nearest 2° F		
<b>SURFACE</b>		
4. Pick correct thermometer		
5. Procedure <ul style="list-style-type: none"> <li>- <i>Spot Check Disc</i>, place on surface until needle stops moving</li> <li>- <i>Infrared</i>, follow manufacturer recommendations</li> <li>- <i>Mercury or Max-Min</i>, place under wooden box wait 5 minutes</li> <li>- <i>Digital</i>; follow manufacturer recommendations</li> </ul>		
6. Document to nearest 2° F		
<b>ASPHALT MIXTURE</b>		
7. Pick correct thermometer		
8. Procedure <ul style="list-style-type: none"> <li>- <i>Infrared</i>, follow manufacturer recommendations</li> <li>- <i>Armored, BI-Therm Dial, or Digital</i>, place stem into mixture and wait until thermometer reading has stabilized</li> </ul>		
9. Document to nearest 5° F		

PASS PASS

FAIL FAIL

Examiner: \_\_\_\_\_ Date: \_\_\_\_\_



## 106.3.2.20 TM-20, Measurement of Air, Surface or Bituminous Mixture Temperature

From Engineering Policy Guide

Jump to: [navigation](#), [search](#)

This method describes the equipment and procedures required to determine air temperature, surface temperature of a base or pavement, and bituminous mixture temperature in the loose state.

### 106.3.2.20.1 Apparatus

**Infrared Thermometer.** Used for surface and loose bituminous mixture temperature determination. The thermometer should register in the range of 20° F to 400° F, with a maximum increment of 2 °F. Operation of this instrument should be based on the manufacturer's instructions.

**Mercury Thermometer.** Used for air or surface temperature determination. Typically, a straight glass thermometer or a U-shaped glass thermometer in a plastic housing commonly referred to as a MAX-MIN thermometer. The thermometer should register in the range of 20° F to 130° F, with a maximum increment of 2 °F.

**Armored Thermometer.** Used for loose bituminous mixture temperature determination. The thermometer should register in the range of 50° F to 400° F, with a maximum increment of 5 °F.

**Bi-Therm Dial Thermometer.** Used for loose bituminous mixture temperature determination. The thermometer should register in the range of 50° F to 400° F, with a maximum increment of 5 °F.

**Spot Check Disc Thermometer.** Used for surface temperature determination. The thermometer should register in the range of 32° F to 250° F, with a maximum increment of 2 °F.

**Digital Thermometer.** Used for air surface or bituminous mixture temperature determination. Thermometer will measure temperature in the range of 0° F to 400° F as a minimum with a maximum increment of 1° F. Thermometer will have a remote probe and may have recording capabilities of maximum and minimum temperature reading. Thermometer, when purchased, shall have a record of calibration to NIST Traceable Standards provided.

**Wooden Box.** Used to cover a mercury thermometer when determining the temperature of a base or pavement. The box will be wooden with a material thickness of not less than 3/8 in. The minimum inside dimensions will be 2 in. tall, 3 in. wide and 14 in. long. The bottom side of the box is to be left open. The bottom edge of the sides and ends shall have attached a strip of foam rubber 3/16 in. thick and the same width as the thickness of the side and end boards. The outside of the box shall be painted with aluminum paint. See Fig. 106.3.2.1.20, below, for a pictorial description.



**Calibration of Thermometers.** Thermometers shall be calibrated **annually** against a known standard.

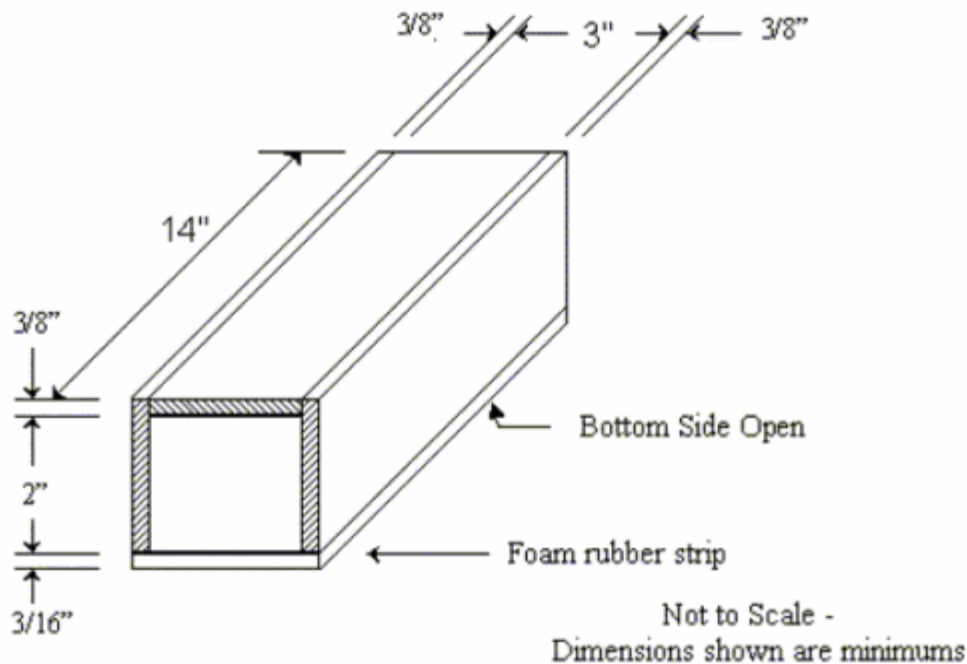

**Fig. 106.3.2.1.20**

### 106.3.2.20.2 Procedure

**Air Temperature.** The mercury thermometer or digital thermometer probe shall be positioned in a shaded area and shall not be exposed to direct sunlight. The thermometer shall be 4.5 ft. above surface level, measured from the surface to the bulb of the thermometer. Care should be taken to ensure no artificial heating or cooling occurs near the thermometer. The thermometer will be left in this location until the reading stabilizes. Air temperature shall be recorded to the nearest 2 °F.

**Surface Temperature, mercury thermometer.** The thermometer cannot be disturbed for at least 5 minutes while conducting this test, so select a location where this criterion can be met. Place the thermometer on the test surface and place the wooden box firmly over the thermometer ensuring the foam rubber strips are in contact with the test surface. The box should remain over the thermometer for a minimum of five minutes. After the 5 minutes, tip the box on edge only far enough to read the thermometer. The surface temperature shall be recorded to the nearest 2 °F.

**Surface Temperature, infrared thermometer.** When using an infrared thermometer, follow the manufacturer's recommended procedure. When obtaining the temperature of a surface, make sure air currents do not affect the reading. The surface temperature shall be recorded to the nearest 2 °F.

**Surface Temperature, spot check disc thermometer.** Place the thermometer on the surface and wait until the needle stops moving. Read the temperature. The surface temperature should be recorded to the nearest 2 °F.

Surface Temperature, digital thermometer. The thermometer probe cannot be disturbed for at least 5 minutes while conducting this test, so select a location where this criterion can be met. Place the thermometer probe on the test surface and place the wooden box firmly over the thermometer probe ensuring the foam rubber strips are in contact with the test surface. The box should remain over the thermometer probe for a minimum of five minutes. After the 5 minutes, read display of thermometer. The surface temperature shall be recorded to the nearest 2 °F.

Bituminous Mixture Temperature armored or Bi-Therm Dial - The thermometer shall have the stem of the thermometer embedded in the loose bituminous mixture. The thermometer should not be disturbed until the thermometer reading has stabilized. When the thermometer has stabilized, read the thermometer. The bituminous mixture temperature shall be recorded to the nearest 5 °F. A digital thermometer that has a range capable of measuring the bituminous mixture temperature and a probe that can withstand the mixture temperature can be used in lieu of an armored or bi-therm dial thermometer.

Bituminous Mixture Temperature, infrared - The thermometer shall be used as recommended by the manufacturer. The location for determining the temperature of the loose bituminous material shall be either in the delivery truck bed, the receiving hopper of the paver or MTV, or at the material head at the end of the paver augers prior to entering the paver screed. The bituminous mixture temperature shall be recorded to the nearest 5 °F.



# AASHTO R60

ASTM C172

## Sampling of Freshly Mixed Concrete

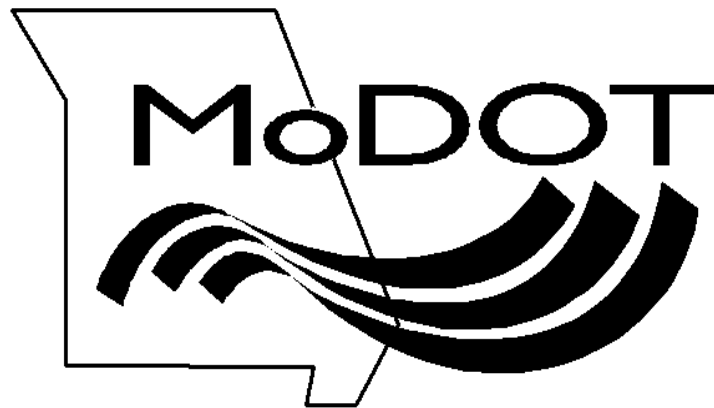





# AASHTO R60

## Sampling Freshly Mixed Concrete



Rev 10/16/2023

1

---

---

---

---

---

---

---

---

### **SCOPE**

- This method covers the procedures for obtaining representative samples of fresh concrete as delivered to the project site and which tests are to be performed to determine compliance with quality requirements of the specifications under which the concrete is furnished.
- This method includes sampling from stationary, paving, and truck mixers and from agitating and non-agitating equipment used to transport central mixed concrete.

2

2

---

---

---

---

---

---

---

---

### **TERMINOLOGY**

- Composite Sample - A sample which is made by combining samples from two or more locations/parts.

More definitions in the glossary.

3

3

---

---

---

---

---

---

---

---

## **SIGNIFICANCE AND USE**

- This practice is intended to provide standard requirements and procedures for sampling freshly mixed concrete from different containers used in the production or transportation of concrete.



4

---

---

---

---

---

---

---

---

4

Significance and Use

- The detailed requirements as to materials mixtures, air content, temperature, number of specimens, slump, Interpretation of results, precision and bias are described in specific test methods.

5

---

---

---

---

---

---

---

---

5

**Fresh concrete will be sampled from one of the mixers listed below;**

- **Stationary Mixers**  
(Except Paving Mixers)
- **Paving Mixers**
- **Revolving Drum Truck Mixers or Agitators**

6

---

---

---

---

---

---

---

---

6

## MoDOT – Sampling Note

- **EPG = Engineering Policy Guide**
- EPG, section **501.4 Sampling** – Sampling of fresh concrete will be in accordance with AASHTO R60, except for central or truck mixed concrete.
- This will be discussed after AASHTO R60.

7

---

---

---

---

---

---

---

---

7

## EQUIPMENT

- Square nose shovel
- Scoop
- Testing equipment
- Sample container
- Tags, molds
- Safety equipment – Personal Protective Equipment (PPE)



8

8

---

---

---

---

---

---

---

---

## Six things to take care of before sampling begins...



9

9

---

---

---

---

---

---

---

---

**1. Communicate with the contractor to coordinate sampling and to talk about SAFETY.**



Before Sampling

10

10

---

---

---

---

---

---

---

---

**2. Set-up a testing area close to the site of sampling, with all testing equipment ready to go.**



Before Sampling

11

11

---

---

---

---

---

---

---

---

**3. Check ticket information on the load when the truck arrives on the job site.**

Take note of the following...

- Name of concrete plant
- Serial number of ticket
- Truck number when a truck mixer is utilized
- Name of Contractor
- Job Number, route and county designation
- Specific class of concrete
- Quantity of concrete in cubic yards
- Date and time when batch was loaded or of first mixing of cement and aggregate
- Number of revolutions when truck mixed

Before Sampling

12

12

---

---

---

---

---

---

---

---

4. Wait until all additives and water have been added and mixed into the load.

5. Wait a minimum of 30 revolutions of the drum, after final change to mix, to make sure all is mixed well.. (MoDOT)

6. Discharge approximately 1 cubic yard before sampling. (MoDOT)

**NOTES:**

- Do not obtain the sample from the very first or last part of the batch discharge.
- Collect enough fresh concrete to complete all tests.

Before Sampling

13

---

---

---

---

---

---

---

---

13

# SAMPLING



14

---

---

---

---

---

---

---

---

14

- Sample the concrete by passing the sample container through the entire concrete stream or move the shoot into the container.

AASHTO Sampling

15



---

---

---

---

---

---

---

---

15

- The elapsed time shall not exceed **15min** between obtaining the first and final portions of obtaining the composite sample.



AASHTO Sampling

16

---

---

---

---

---

---

---

---

16

- Transport the samples to the place that was set-up earlier for testing fresh concrete and molding specimens.



AASHTO Sampling

17

---

---

---

---

---

---

---

---

17

- The concrete sample portions shall be mixed with a shovel just enough to ensure uniformity.



AASHTO Sampling

18

---

---

---

---

---

---

---

---

18

- Protect the sample from the **sun, wind, moisture**, and other sources of rapid evaporation and from contamination.

AASHTO Sampling

19

---

---

---

---

---

---

---

---

19

- After mixing with a shovel, start tests for slump, temperature, and air content within **5 minutes**.
- **Complete these tests quickly!**

TESTING: SLUMP, TEMP, AIR

20

---

---

---

---

---

---

---

---

20

- Start molding specimens for strength tests (cylinders and beams).
- Complete all required tests within **15 min** after fabricating the composite sample.

MOLDING SPECIMENS

Complete everything within 30 minutes.

21

---

---

---

---

---

---

---

---

21



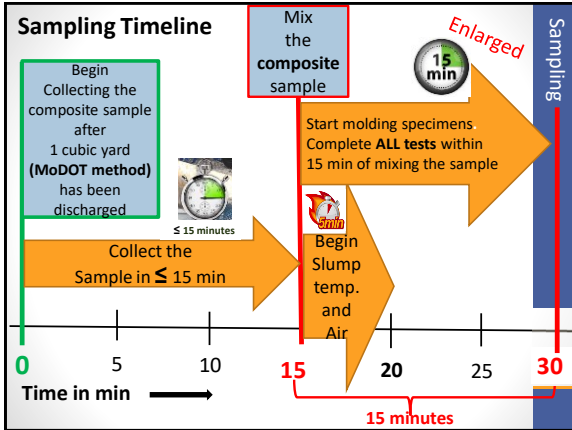

22

---

---

---

---

---

---

---

---

**PROCEDURE**

- Size of Sample – The sample to be used for strength tests, will need at least a minimum of 1 cubic foot. (1ft<sup>3</sup>).

**MODOT:** Sample enough to do all tests.

- **Exception:** Smaller samples could be used if air content and slump tests are the only tests.

23

23

---

---

---

---

---

---

---

---

**MIXERS**

- **Stationary Mixers**  
(Except Paving Mixers)
- **Paving Mixers**
- **Revolving Drum Truck Mixers or Agitators**

24

24

---

---

---

---

---

---

---

---



## STATIONARY MIXERS



25

25

---

---

---

---

---

---

---

---

### Sampling from Stationary Mixers (Except Paving Mixers)

Stationary Mixers

- Obtain two or more portions taken at regularly spaced intervals during discharge of the middle of the batch.
- Obtain these portions within the time limit of 15 min.
- Combine the portions into the composite sample for testing purposes.

26

26

---

---

---

---

---

---

---

---

- Perform sampling by passing a receptacle completely through the discharge stream or by completely diverting the discharge into a sample container.
- If the discharge of the concrete is too rapid to divert the complete discharge stream, discharge the concrete into a container or transportation unit sufficiently large enough to accommodate the entire batch and then accomplish the sampling.

Stationary Mixers

27

27

---

---

---

---

---

---

---

---

- Take care not to restrict the flow of concrete from the mixer, container, or transportation unit so as to cause segregation.
- These requirements apply to both tilting and non-tilting mixers.

---

---

---

---

---

---

---

---

28

- **NOTE:** No sample should be taken before 10 percent or after 90 percent of the batch has been discharged. Due to the difficulty of determining the actual quantity of concrete discharged, the intent is to provide samples that are representative of widely separated portions but not the beginning or end of the load.

---

---

---

---

---

---

---

---

29

### CONTINUOUS MIXERS



New Slide

---

---

---

---

---

---

---

---

30

- Do not collect from very first or last portions of a mixer's continuous discharge.
- After all mixture adjustments have been made,
- Discharge 5 ft<sup>3</sup> of concrete.
- Obtain 2 or more portions at regularly spaced intervals during discharge of the concrete by passing a receptacle through the entire discharge stream or by completely diverting the discharge into a sample container.
- Staying within the time limits.
- Combine into one composite sample for testing purposes.
- Then wait 2 to 5 min. before testing.
  - The waiting period is needed because the mix water was input only seconds before the discharge.

Continuous Mixers

31

New Slide

31

---

---

---

---

---

---

---

---

## PAVING MIXERS



32

32

---

---

---

---

---

---

---

---

- For Central Mixed concrete delivered to a paving operation:
  - Sample the concrete after the contents of the paving mixer have been discharged.
  - Obtain samples from at least **FIVE** different locations of the pile after the concrete is on the sub-grade and then combine them into one sample for testing purposes.

Paving Mixers

33

33

---

---

---

---

---

---

---

---

- Avoid contamination with subgrade material. To preclude contamination or absorption by the subgrade:
  - Sample the concrete by placing three shallow containers on the subgrade and discharging concrete across the containers.

---

---

---

---

---

---

---

---

34

- Combine the samples into one sample for test purposes.
- Mix your sample with a **square nose** shovel to ensure uniformity and eliminate segregation.
- The containers shall be of a size sufficient to provide a composite sample size that agrees with the maximum aggregate size.

---

---

---

---

---

---

---

---

35

### REVOLVING DRUM TRUCK MIXERS or AGITATORS



---

---

---

---

---

---

---

---

36

**AASHTO R60 procedure . . .**

- Sample the concrete by collecting two or more portions taken at regularly spaced intervals during discharge of the middle portion of the batch.
- Take the samples obtained within the time limit specified and combine them into one sample for test purposes.

NOTE: MODOT will release 1 Cubic Yard before sampling for truck mixed or truck delivered mixes. See MoDOT section.

37

---

---

---

---

---

---

---

---

37

- Sample by repeatedly passing a receptacle through the entire discharge stream or by completely diverting the discharge into a sample container.

Regulate the rate of discharge of the batch by the rate of revolution of the drum, **not** by the size of the gate opening.



38

---

---

---

---

---

---

---

---

38

**WET – SIEVING CONCRETE**

(Only when necessary)  
ASTM C172

- When the concrete contains aggregate larger than the appropriate size for the molds or equipment to be used, Wet-Sieve the sample.

39

---

---

---

---

---

---

---

---

39

**Wet-Sieving Video** <https://youtube.com/NH2VdzH5k>



Wet-Sieving Concrete

40

**NOTE:** Use a square nose shovel

40

---

---

---

---

---

---

---

---

**Additional Procedure for Large, Maximum-Size Aggregate Concrete**

- If the sample consists of large maximum-sized aggregate, perform this procedure before running tests.
- **Exception:** Perform density (unit weight) tests for use in yield computations on the full mix (As received, large aggregate and all).

41

41

---

---

---

---

---

---

---

---

• **Equipment** for wet-sieving concrete shall be a sieve of suitable size and conveniently arranged and supported so that one can shake it rapidly by either hand or mechanical means. Generally, a horizontal back-and-forth motion is preferred.

**Receptacle;** a container of suitable size having a nonabsorbent surface, like a wheelbarrow.



42

42

---

---

---

---

---

---

---

---

- How to Perform Wet –Sieving:**
- After sampling the concrete and before remixing, pass the concrete over the designated sieve.
  - Shake or vibrate the sieve by hand or mechanical means until no undersize material remains on the sieve.
  - Remove and discard the aggregate retained.
- NOTE:** Do not wipe off the mortar on the retained aggregate.

---

---

---

---

---

---

---

---

43

- Place only enough concrete on the sieve at any one time so that, after sieving, the thickness of the layer of retained aggregate is not more than one particle thick.
- The concrete that passes the sieve shall fall into a batch pan of suitable size that has been dampened before use or onto a clean, moist, nonabsorbent surface.

---

---

---

---

---

---

---

---

44

- Scrape any mortar adhering to the sides of the wet-sieving equipment into the batch.
- After removing the larger aggregate particles by wet-sieving, remix the batch with a shovel in the minimum amount necessary to ensure uniformity and proceed testing immediately.

---

---

---

---

---

---

---

---

45

## MoDOT Sampling Category 501 - Concrete Engineering Policy Guide



46

---

---

---

---

---

---

---

---

46

### MoDOT - Collection for Truck Mixed or Truck Delivered – Concrete Sampling

- EPG, section 501.4 ***Fresh Concrete Sampling*** – Sampling of fresh concrete shall be in accordance with AASHTO R60, except for central or truck mixed concrete.
- For central or truck mixed concrete the entire sample for temperature, slump, air-content and for molding compressive strength specimens may be taken at one time after all additives and water have been mixed and approximately **one cubic yard** of concrete has been discharged.

47

---

---

---

---

---

---

---

---

47

### MoDOT - Collection for Truck Mixed or Truck Delivered – Concrete Sampling

- Each time water or any admixture is added, the drum shall be turned an additional 30 revolutions, minimum, to mix water into concrete (Standard Specification Section 501.8.6)
- Move the concrete chute so concrete flows into your sample container or passes your sample catcher completely through the stream of concrete.

48

---

---

---

---

---

---

---

---

48



- When a **Concrete Pump Truck** is being used
  - The designated location to obtain your concrete sample is at the point of truck discharge for quality control (see EPG section 501.1.3, section 501.4).
  - Slump and Air Content will be checked when a pump is first used and periodically, at the truck discharge as well as the pump discharge to compare properties.

---

---

---

---

---

---

---

---

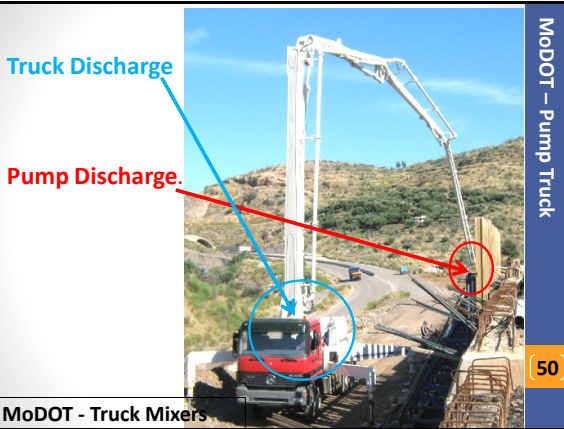

---

---

---

---

---

---

---

---

**Common Errors**

- Sample taken before water is added and all mixing is completed.
- Letting sample set too long before testing.
- Sample contains mud, debris, base rock, unmixed materials.
- Unclean equipment.
- Not periodically checking the difference in properties between the truck discharge and the pump discharge.

---

---

---

---

---

---

---

---



# Sampling Time Line

Begin  
Collecting the  
composite sample  
after  
1 cubic yard  
(MoDOT method)  
has been  
discharged



≤ 15 minutes

Collect the  
Sample in ≤ 15 min

0 5 10  
Time in min →

Sampling

Mix  
the  
composite  
sample

Enlarged



Start molding specimens.  
Complete ALL tests within  
15 min of mixing the sample



Begin  
Slump  
temp.  
and  
Air

15 20 25 30  
15 minutes

Sampling



## Category: 501 Concrete – Engineering Policy Guide

### **501.1.3 Sampling (Sec 501.4 Standard Specifications)**

Sampling of fresh concrete by these instructions will meet the requirements of Section 501.4 of the Standard Specifications. Each sample should be large enough to permit completion of all necessary tests. Methods described should be tempered with judgment to assure that samples are as nearly as possible representative of the true nature and condition of the concrete sampled. For safety reasons, sampling should always be coordinated through contractor personnel.

#### **501.1.3.1 Pumping Concrete**

There has been discussion about the proper place to sample concrete when it is being pumped. The following guidelines will assure uniformity of contract enforcement statewide.

Ordinarily the most representative sample will be taken at the point of final discharge. For safety reasons, however, it is not always practical to do so. When concrete is being pumped our procedure has been to take samples at the truck chute. Usually there is no significant difference unless a new or reconditioned pump is being used, the concrete is being pumped a long distance or if there are high vertical drops in the line.

The first load should be checked at both points. The difference between the truck and the pump should be checked regularly, especially if there are significant changes in drop or distance, and certainly if a different pump is used.

Consider the change in air content when determining specification compliance. If you find that the air drops by 0.3%, subtract that from the reading at the truck. If you are on the low side at the truck the air should be adjusted accordingly. The correction factor from loss through pumping would also apply to the slump. The reported slump and air content should be what is at the point of placement.

The concrete truck boom shall be configured to minimize the free fall of concrete of the point of discharge. This is to minimize segregation, and loss of air and slump.

#### **501.1.3.2 Sampling from Stationary Mixers Except Paving Mixers**

The sample is to be obtained by passing a receptacle completely through the discharge stream of the mixer at about the middle of the batch, or by diverting the stream completely so that it discharges into a container. Do not restrict flow from the mixer in a way that can cause concrete to segregate. This method should be used for both tilting and non-tilting mixers.

#### **501.1.3.3 Sampling Central or Truck Mixed Concrete**

The entire sample for slump and air tests and for molding compressive strength specimens may be taken at one time, after approximately one cubic yard of concrete has been discharged. The sample shall be taken from at least 5 different parts of the pile. Acceptability of concrete for slump and air content and, when applicable, for strength requirements, will be determined by tests on these samples.

## Category: 501 Concrete – Engineering Policy Guide

### **501.1.3.4 Protection of sample**

After the sample has been obtained, it must be protected from direct sunlight and wind until it is used, which must not be more than 15 minutes after sampling. When the sample has been moved to the place where the test is to be made or specimens are to be molded it should be mixed with a shovel if necessary to assure uniformity of the mixed sample.

### **501.1.3.5 Compressive Strength**

Compressive tests are performed both in the field and in the laboratory on cylindrical specimens of concrete, 6 in. diameter and 12 in. tall (6x12) or 4 in. diameter and 8 in. tall (4x8). The Standard Specifications require use of compressive specimens for job control of concrete production.

All concrete for air and slump tests as well as preparation of the specimens should be secured from a single batch of concrete. Air and slump tests should always be made on samples of concrete used for preparation of compressive specimens.

Cylinder forms shall be filled with fresh concrete in accordance with the instructions provided by AASHTO T 23 (ASTM C 31). Care should be taken when placing the caps on the molds to avoid damage to the surface of the concrete. The lids should be kept on tight to prevent moisture loss.

#### **501.1.3.5.1 Curing**

Curing of compressive specimens will depend on whether they are for standard cure or field cure.

Standard Cure is defined as 1) specified strength for 28-day testing; 2) Check of mixture proportions or design strength; 3) Quality control (i.e. monitoring mix variability) or 4) Maturity meter curve.

Standard curing involves two phases of curing: initial and final.

Each set of compressive test specimens for standard cure consists of two 6x12 cylinders or three 4x8 cylinders. Standard Cure specimens shall be cured in accordance with AASHTO T23 (ASTM C31) for initial and final curing.

#### **Standard Cure – Initial**

If specimens cannot be molded at the place where they will receive initial curing, immediately after finishing move the specimens to an initial curing place for storage. Recommended method for initial curing is keeping the specimen in the plastic mold covered with a plastic lid or place in a damp sand pit for a maximum of 48 hours in a temperature range from 60° F to 80° F and an environment preventing moisture loss.

# AASHTO R60 Sampling Freshly Mixed Concrete PROFICIENCY CHECKLIST

Applicant: \_\_\_\_\_

Employer: \_\_\_\_\_

	Trial#	1	2
Checked for required equipment: square nose shovel, scoop, sample container, testing equipment for Slump, Air-Content, Temperature, Strength tests, safety equipment, PPE, tags, molds.			
1. Communicate with the contractor to coordinate sampling and for safety purposes.			
2. Set-up a testing area with all testing equipment			
3. Collected ticket information on the load, name of concrete plant, job#, etc.			
4. Waited until all additives and water were added and mixed into the load			
5. After final additions, wait a minimum of 30 revolutions			
5. Collected the fresh sample(s) within 15 minutes from one of the following sources: <b>-Truck Mixed- Revolving Drum per MoDOT Method</b> *Discharged a minimum of 1 cubic yard *Passed a receptacle completely through the discharge stream or by diverting the discharge chute into a sample container *Collected enough fresh concrete to do all tests *Did not restrict the flow of concrete  <b>-Stationary Mixers</b> *Sampled at the middle of the batch *Obtained 2 or more portions at regular spaced intervals (combined to make composite sample) *Did not restrict flow *Collected enough fresh concrete to do all tests  <b>-Continuous Mixers</b> *Sampled middle portion of the batch *Discharge 5ft <sup>3</sup> of concrete *Obtain 2 or more portions regularly spaced intervals during discharge *Combine into one composite sample to do all tests *Wait 2 to 5 min. before testing  <b>-Paving Mixers</b> at a paving operation *After the contents of the mixer have been discharged *Obtained samples from at least 5 locations (combined to make composite sample) *Collected enough fresh concrete to do all tests *Avoided contamination from subgrade			
7. Performed Wet-Sieving as needed (Except for concrete used for unit weight)			
8. Transported the composite sample to the testing area and remixed with a square nose shovel			
9. Within 5 minutes of mixing the composite sample started tests for Temperature, Air-Content, and Slump			
10. Started molding specimens for strength tests and completed all tests within 15 minutes of mixing the composite sample.			

PASS PASS

Fail Fail

Examiner: \_\_\_\_\_ Date: \_\_\_\_\_





# **ASTM C1064**

## **Temperature of Freshly Mixed Hydraulic-Cement Concrete**

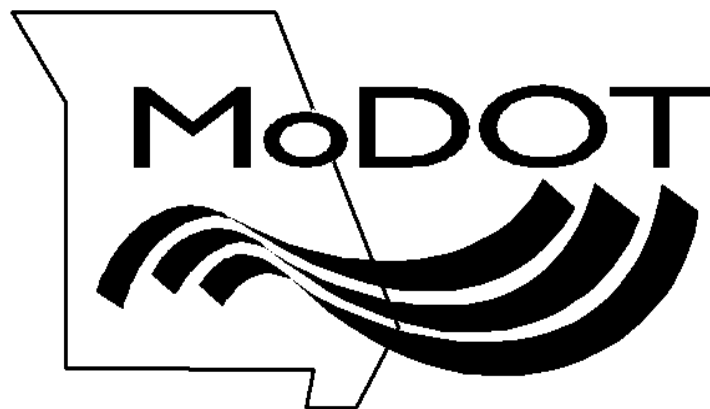



# ASTM C1064

## Temperature of Freshly Mixed Hydraulic-Cement Concrete



Rev 08/18/2023

1

---

---

---

---

---

---

---

---

### SCOPE

- This test method covers the determination of temperature of freshly mixed hydraulic-cement concrete.

2

2

---

---

---

---

---

---

---

---

### TERMINOLOGY

- **NIST - National Institute of Standards and Technology**, is a laboratory, of the United States Department of Commerce.
- **Thermometer** – For this method; refers to any of the devices listed below that are used to measure the temperature of concrete. (Unless the method calls for a specific type of thermometer).
  - Liquid-in-Glass Thermometer (mercury, alcohol, etc.)
  - Electronic Thermometer with probe
  - Dial Thermometer

See the glossary for more definitions.

3

3

---

---

---

---

---

---

---

---

## **SIGNIFICANCE AND USE**

- This test method provides a means for measuring the temperature of freshly mixed concrete. The measured temperature represents the temperature at the time of testing and may not be an indication of the temperature of the freshly mixed concrete at a later time. It may be used to verify conformance to a specified requirement for temperature of concrete.

4

4

---

---

---

---

---

---

---

---

- Concrete containing aggregate of a nominal maximum size greater than **3 inches**, may require up to **20 min.** for the transfer of heat from aggregate to mortar.

Significance and Use

5

5

---

---

---

---

---

---

---

---

## **EQUIPMENT**

- **Container**
  - Will be large enough to provide at least **3"** of concrete in all directions around the sensor of the thermometer; concrete cover must also be at least **three** times the nominal maximum size of the coarse aggregate.
  - **Container examples:** 6" cylinder mold, wheelbarrow, forms, drop bucket, non-mixing transport vehicle etc.
  - **Do not** check temperature inside of a mixer truck, for safety concerns

6

6

---

---

---

---

---

---

---

---

### Container: 6" Cylinder Mold



- A cylinder mold that is **6"** in diameter is acceptable for the required **3"** coverage around the probe or a bulb of the thermometer or as long as the thermometer bulb is in the center.

Equipment

7

7

---

---

---

---

---

---

---

---

### Thermometer

- Capable of accurately measuring the temperature of the freshly mixed concrete to **±1°F** ( $\pm 0.5^{\circ}\text{C}$ ) throughout a range of 30° to 120°F (0° to 50°C).
- Allows **3"** or more immersion during operation.
- Verified annually, or whenever there is a question of accuracy.

Equipment

8

8

---

---

---

---

---

---

---

---

### • Partial immersion liquid-in-glass thermometers:

- The partial immersion thermometer is not to be immersed past the permanent black line.
- Many immersion lines are 76mm = 2.99 inches.



New Slide

9

9

---

---

---

---

---

---

---

---

**Reference Thermometers;** These thermometers are mainly used for verifying other thermometers and are NIST traceable. Keep all certificates in the lab for viewing.



Equipment

10

10

---

---

---

---

---

---

---

---

**Verification of the Accuracy of Thermometers**

Thermometers used in testing Concrete must be verified against an NIST traceable Reference Thermometer **every year** or whenever there is a question of accuracy.



Equipment

11

11

---

---

---

---

---

---

---

---

- A company may send the thermometers off to another company to be verified.

**OR**

- A company may verify the thermometers in house, **see appendix** for more information on verifying the accuracy of thermometers.

- **MoDOT personnel:** Check with your supervisor for information on verifying thermometers.

Equipment

12

12

---

---

---

---

---

---

---

---

## **SAMPLING**

- It is acceptable to measure the temperature of freshly mixed concrete in either the transporting equipment or the forms after discharge provided the sensor of the temperature measuring device has at least **3"** of concrete cover in all directions.
- If the transporting equipment or placement forms are not used as the container, a sample shall be prepared as follows:

13

13

---

---

---

---

---

---

---

---

- Immediately, prior to sampling the freshly mixed concrete, dampen the container with water.
- Sample the freshly mixed concrete in accordance with ASSHTO R 60. The composite sample is not required if the only purpose for obtaining the sample is to determine temperature.
- Place the freshly mixed concrete into the container.

Sampling Concrete

14

14

---

---

---

---

---

---

---

---

## **PROCEDURE**

- Position the thermometer so that the end of the temperature sensing portion is submerged a minimum of **3"** into the freshly mixed concrete.
- Close the void around the thermometer by gently pressing the concrete against the thermometer at the surface of the concrete to prevent ambient air temperature from affecting the reading.

15

15

---

---

---

---

---

---

---

---

## TESTING - Temperature of Concrete



Procedure

16

16

---

---

---

---

---

---

---

---

- Leave the temperature measuring device in the freshly mixed concrete from **2 to 5 min.**
- Read and record the temperature to the nearest **1°F (0.5°C).**

**NOTE:** Do not remove the device from the concrete when reading the temperature.

Procedure

17

17

---

---

---

---

---

---

---

---

## **REPORT**

- Report the measured temperature of the freshly mixed concrete to the nearest **1°F (0.5°C).**

18

18

---

---

---

---

---

---

---

---



occasionally necessary to loosen the insulation to balance the temperature rise.

3. In severely cold weather, to prevent the conduction of cold by the protruding reinforcing steel, it may be necessary to provide supplemental heat at critical points.

4. Care should be taken to check the temperature periodically at critical points until the concrete has reached its required strength.

### 703.2.11 Hot Weather Concreting

Placement of superstructure concrete shall not be done when the ambient temperature is above 85°F.

The internal temperature of the concrete shall not be greater than 85°F at the time of placement in the forms, regardless of ambient temperature.

**Procedures For Checking Surface And Ambient Temperatures** - MoDOT Test Method TM-20 Measurement of Air, Surface or Bituminous Mixture Temperature describes the methods for checking surface temperatures and air temperatures in the immediate vicinity of the work.

### 703.2.12 Checklist

The following checklist is provided as a guide to the inspector during the sequence of operations associated with a deck pour.

#### Checklist For Pouring Bridge Slab

Prior to Pour

Concrete

Where is it to be obtained?

Has batching equipment been checked?

Have truck mixers been checked?

How many yards are in the pour?

Does the contractor have sufficient quantities of inspected-air-entraining agent, cement, sand, stone and water?

Has moisture test been run?

Who is the plant inspector?

Read the specifications on this phase of the work?

Is plant inspector familiar with the plant?

Falsework and Forms

Do we have falsework drawings?

Did the contractor follow these drawings?

Has splicing and blocking been kept to a minimum?

Is the falsework on sound footing?

Was acceptable form lumber used?

Will form ties break behind concrete surface?

Are all forms nailed down?

Do the forms fit tight?

Was a mill cut molding used for bevels?

Have the forms been oiled?

Is there an excess of oil on forms?

Is a method of checking settlement provided?

Has line and grade of forms been checked?

Are all jacks tight and secured?

Read specifications for all material and equipment requirements.



## ASTM C1064 Temperature of Freshly Mixed Hydraulic-Cement Concrete PROFICIENCY CHECKLIST

Applicant: \_\_\_\_\_

Employer: \_\_\_\_\_

		Trial#	1	2
1.	Thermometer verified annually to an NIST traceable thermometer			
2.	Sensing portion of thermometer submerged a minimum of 3 inches into concrete			
3.	Concrete gently pressed around thermometer at surface of concrete			
4.	Thermometer left in concrete for at least 2 minutes but not more than 5 minutes			
5.	Read and reported the temperature to the nearest 1°F (0.5°C)			

PASS    PASS

FAIL    FAIL

Examiner: \_\_\_\_\_ Date: \_\_\_\_\_



# **AASHTO T119**

ASTM C143

## **Test for Slump of Hydraulic Cement Concrete**

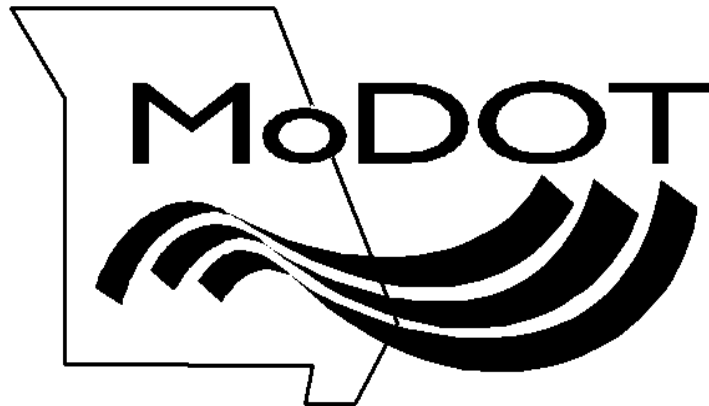



# AASHTO T119

## Test for Slump Of Hydraulic Cement Concrete



Rev 08/31/2023

1

---

---

---

---

---

---

---

---

### SCOPE

- This test method covers determination of slump of concrete, both in the laboratory and in the field.
- **NOTE:** Concretes having slumps less than 0.5 inches may not be adequately plastic and concretes having slumps greater than about 9 inches may not be adequately cohesive for this test to have significance.

2

2

---

---

---

---

---

---

---

---

### SUMMARY

- A sample of freshly mixed concrete is placed and compacted by rodding in a mold in the shape of a cone in 3 layers, each approximately  $\frac{1}{3}$  of the volume of the mold.
- The mold is raised, and the concrete allowed to subside.
- The vertical distance between the original and the displaced position of the center of the top surface of the concrete is measured and reported as the slump of the concrete.

3

3

---

---

---

---

---

---

---

---

## **SIGNIFICANCE AND USE**

- This test method is intended to provide the user with a procedure to determine the slump of plastic hydraulic cement concretes.
- This test method is considered applicable to plastic concrete having coarse aggregate passing the 1½ (37.5mm) inch sieve.
- If the plastic concrete includes aggregate larger than 1½ inch (37.5mm), the larger aggregate particles are to be removed using **wet-sieving** as explained in R60.

4

4

---

---

---

---

---

---

---

---

- This test method is not considered applicable to non-plastic and non-cohesive concrete.

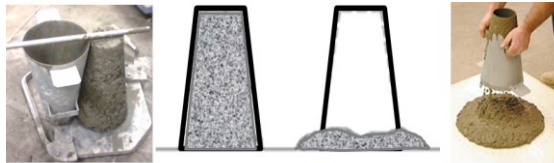

**Zero Slump**  
Potentially  
non-plastic

**Collapsed Slump**  
Potentially  
non-cohesive

Significance and Use

5

5

---

---

---

---

---

---

---

---

## **EQUIPMENT**

### **Mold – “Slump Cone”**

The mold must be free from dents, deformations, or adhered mortar.

- #16 gage metal
- Top diameter of 4±1/8”
- Bottom diameter of 8±1/8”
- Height of 12±1/8”.
- Foot pieces & Handles
- Clamps to nonabsorbent base plate
- Large enough to contain all the slumped concrete



**NOTE:** Information on Cone molds made from material other than metal see AASHTO T119.

6

6

---

---

---

---

---

---

---

---



<ul style="list-style-type: none"> <li>• <b>Tamping Rod</b> –</li> <li>–straight steel rod</li> <li>–circular x-section</li> <li>–<math>\frac{5}{8} \pm \frac{1}{16}</math>" diameter</li> <li>–<math>24 \pm 4</math>" in length</li> <li>–one end shall be rounded to a Hemispherical shape <math>\frac{5}{8}</math>" in diameter.</li> </ul>	<ul style="list-style-type: none"> <li>• <b>Measuring Device</b>–</li> <li>–Rigid Ruler</li> <li>–Metal roll-up tape</li> <li>–Marked in <math>\frac{1}{4}</math>" increments</li> <li>• <b>Scoop</b>–</li> <li>–Large enough to obtain a sample but small enough not to spill during testing.</li> <li>• <b>Base Plate</b>–</li> <li>–Flat, level, rigid, and nonabsorbent</li> </ul>
Equipment	7

---

---

---

---

---

---

---

---

7

<b><u>SAMPLE</u></b>
<ul style="list-style-type: none"> <li>• Obtain a representative sample of cement concrete according to AASHTO R60.</li> </ul> <p><b>NOTE:</b></p> <ul style="list-style-type: none"> <li>• Particles larger than 37.5mm (1½ in.), remove according to Section 6 of AASHTO R60.</li> <li>• Slump testing shall begin within 5 minutes of obtaining the sample.</li> </ul>
<b>8</b>

---

---

---

---

---

---

---

---

8

<b><u>PROCEDURE</u></b>
<ul style="list-style-type: none"> <li>• <b>MoDOT:</b> Concrete slump is to be determined prior to each air-entrainment test taken, and as necessary to maintain proper control of the concrete consistency. See EPG sec 501.</li> <li>• Dampen the inside of the mold and place it on a dampened, rigid, nonabsorbent surface that is level and firm.</li> </ul> <p><b>NOTE:</b> <u>During the test prevent movement of the cone until the lift is performed.</u></p>
<b>9</b>

---

---

---

---

---

---

---

---

9

Hold the mold firmly in place during filling and perimeter cleaning by standing on the two-foot pieces or by clamping the foot pieces to a base plate.



Procedure

10

10

---

---

---

---

---

---

---

---

- **(1<sup>st</sup> Layer)** Using the scoop, fill the mold **one-third full** by volume, to a depth of approximately **2.75 in. (70mm)**.
- Consolidate, with **25 strokes** of the tamping rod, using the rounded end, being careful to completely remove rod from concrete between strokes.
- Distribute the strokes evenly over the entire cross section of the concrete.
- For the bottom layer, incline the rod slightly and make approximately half the strokes near the perimeter, then progress with vertical strokes, spiraling toward the center. **Rod the bottom layer through its depth.**

11

11

---

---

---

---

---

---

---

---

- **(2<sup>nd</sup> Layer)** Use the scoop to fill the mold **two-thirds full** by volume, to a depth of approximately **6.5 in. (160mm)**.
- Consolidate, with **25 strokes** of the tamping rod; penetrate approximately **1 inch** into the bottom layer.
- Distribute the strokes evenly.

Procedure

12

12

---

---

---

---

---

---

---

---

**(3<sup>rd</sup> Layer)** Fill the mold to overflowing. Consolidate with **25 strokes** of the tamping rod; penetrate approximately **1 inch** into the 2<sup>nd</sup> layer. Distribute the strokes evenly.

If the concrete falls below the top of the mold, stop, add more concrete, and continue rodding for a total of 25 strokes. Keep an excess of concrete above the top of the mold at all times. Distribute the strokes evenly.



Procedure

13

---

---

---

---

---

---

---

---

- After the top layer has been rodded, strike off the top using a screeding and rolling motion of the tamping rod.



Procedure

14

14

---

---

---

---

---

---

---

---

- Clean around the base of the mold; carefully raise the mold vertically 12 inches in **5 ± 2 seconds** by a steady upward lift with no lateral or twisting motion.

- Complete the test from filling to mold removal in **≤ 2 ½ minutes**.



Procedure

15

15

---

---

---

---

---

---

---

---

- Immediately turn the mold upside down next to the specimen.
- Place the tamping rod across the mold so that it is over the test specimen.
- Measure the distance between the bottom of the rod and the **displaced original center** of the top of the specimen to the nearest  $\frac{1}{4}$ " (5mm).



**Note:** Do Not reuse the tested specimen for project related materials.

Procedure

16

16

---

---

---

---

---

---

---

---

- If a decided falling away or shearing off of concrete from one side or portion of the mass occurs, disregard the test and make a new test on another portion of the sample.

**NOTE:** If two consecutive tests on a sample of concrete show a falling away or shearing off, the concrete probably lacks necessary plasticity and cohesiveness for the slump test to be applicable.



Procedure

17

17

---

---

---

---

---

---

---

---

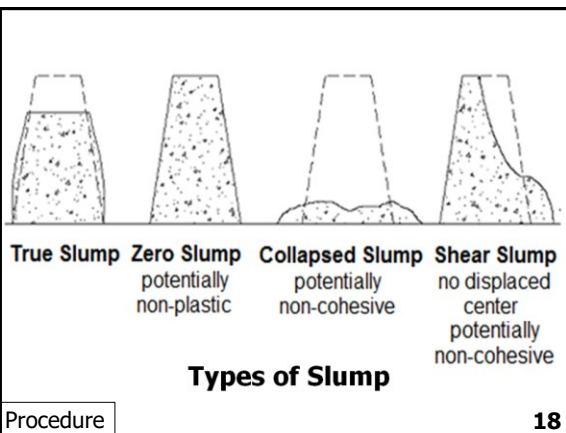

Procedure

18

18

---

---

---

---

---

---

---

---

Enlarged



This concrete is a bit too stiff it will be difficult to pour and vibrate properly, raising the risk of voids.

**ZERO-SLUMP**

This concrete has about a 3.5-inch Slump. It's wet enough to be poured and vibrated properly yet dry enough that, as it cures, it will reach maximum strength.

**TRUE-SLUMP**

Excessive slump means the concrete has too much water. It's likely to shrink excessively and crack. It will be significantly weaker than properly hydrated concrete.

**COLAPSED-SLUMP**

Procedure **19**

---

---

---

---

---

---

---

---

19

## REPORT

- Record the slump in terms of inches to the **nearest 1/4 inch** (5mm) of subsidence of the off-set center of the specimen during the test.
- See MoDOT EPG sec 501 for additional information.

**20**

---

---

---

---

---

---

---

---

20

### What's Wrong with these tests?

Not a good test!



**21**

---

---

---

---

---

---

---

---

21



22

---

---

---

---

---

---

---

---



23

---

---

---

---

---

---

---

---



24

---

---

---

---

---

---

---

---

**GREAT JOB TESTING SLUMP!**



25

25

---

---

---

---

---

---

---

---





# AASHTO T119

## Slump of Hydraulic Cement Concrete

### PROFICIENCY CHECKLIST

Applicant: \_\_\_\_\_

Employer: \_\_\_\_\_

Trial#	1	2
1. A Clean Slump Cone damped and placed on a moist, flat, level, nonabsorbent rigid surface		
2. Cone secured by clamps or by standing on foot pieces while filling the cone in three equal layers and while rodding		
3. Each layer approximately $\frac{1}{3}$ the volume of the mold		
4. Each layer rodded 25 times		
5. Layers rodded properly a. First layer rodded through entire depth while inclining the rod & spiraling toward center b. Second layer rodded approximately 1" into underlying layer c. Third layer was kept heaped above the cone while rodding approximately 1" into the underlying layer		
6. Used a tamping rod to strike off level with the top of the mold		
7. Cone filled and removed within 2 $\frac{1}{2}$ minutes		
8. Excess concrete cleaned away from the bottom of the mold and plate		
9. Movement/vibration of cone restricted until lift was performed		
10. Cone was lifted vertically without twisting, within $5 \pm 2$ seconds		
11. Immediately placed the mold upside-down next to the slumped concrete		
12. Placed the tamping rod on top of the cone, measured the vertical distance of the displaced original center of the slump to the rod		
13. Slump measured and recorded to the nearest $\frac{1}{4}$ inch		

PASS    PASS

FAIL    FAIL

Examiner: \_\_\_\_\_ Date: \_\_\_\_\_



#### **501.1.4 Consistency (Sec 501.5)**

Consistency (slump) of concrete should be determined each time an air-entrainment test is made. Other tests for consistency of concrete should be made as necessary to maintain proper control of the concrete. Placement of concrete should not be permitted until tests for both air entrainment and consistency have been made and results show that specification requirements have been met. When routine tests indicate a deviation from specifications for consistency, placement should be suspended until adjustments have been made and additional tests completed which show concrete to be within specifications limits. Consistency tests are to be made according to the following instructions which will comply with the specification requirements pertaining to AASHTO designation T-119.

A considerable number of tests have been completed comparing results of testing air entrained concrete samples at the truck discharge point and the pump discharge point. The tests, with few exceptions, indicated that there are only minor variations in the results of the tests, with the tests from the pump discharge location usually slightly lower in air content and slump. If slump goes up drastically there probably would have to be a foreign liquid entering the system from somewhere. A high slump above the 6 to 7 in. range normally indicates a risk of segregation. Timing in taking slump tests is important. The designated location for quality control sampling to determine air content and slump is the point of truck discharge. When any of the following conditions occur, it may be necessary to obtain a check sample at the point of pump discharge to assure that there is no significant variation in test results:

1. When a new or reconditioned concrete pump is placed into operation.
2. When there are any indications that a substantial change in air content or slump has occurred between the two points of discharge.

The mold for use in the performance of the slump test is available on requisition. It will be made of galvanized steel, not thinner than #16 gauge and will have the shape of a frustum of a right circular cone with approximate inside diameters at the top of 4 in. and at the bottom of 8 in. Height will be approximately 12 in. The mold is satisfactory if the above dimensions are within 1/16 in. The mold will have foot pieces, and handles for moving mold at end of the test. A mold which clamps to a nonabsorbent base plate is acceptable.

The tamping rod which is used to consolidate the material in the cone shall be a round, straight, steel rod 5/8 inch in diameter, with one end rounded to a hemispherical tip. Length should be approximately 2 feet.

A sample of concrete from which consistency tests are to be made must be representative of the entire batch. Samples should be obtained in accordance with the method of sampling fresh concrete, Section 501.4 of the Standard Specifications.

The mold, which must be clean, should be dampened and placed on a flat, moist, nonabsorbent rigid surface. Hold the mold firmly in place during filling, by standing on the foot pieces.

From the sample of concrete, fill the mold in three layers, each layer being approximately 1/3 the volume of the mold. One-third of the volume fills it to a depth of about 2-5/8 in., 2/3 of the volume fills it to a depth of about 6-1/8 in.

Rod each layer with 25 strokes of the tamping rod. Distribute strokes uniformly over entire cross section of the layer. For the bottom layer this will necessitate inclining the rod slightly and making approximately one-half of the strokes near the perimeter and then progressing with vertical strokes spiraling toward the center. Rod the bottom layer throughout its depth. The other two layers are to be rodded throughout their depth so that strokes just penetrate into the underlying layer **approximately 1 inch**.

In filling and rodding the top layer, heap concrete above the mold before rodding is started. If during the rodding operation concrete subsides below top of the mold, add additional concrete to keep an excess of concrete above top of the mold. After rodding has been completed, strike off the surface of concrete by means of a screeding and rolling motion of the tamping rod.

Immediately remove the mold from the concrete by carefully raising it in a vertical direction. This should be done in approximately 5 seconds by a steady upward lift with no sideways or twisting motion being imparted to the concrete. The entire operation from start of filling through removal of mold should be carried out without interruption. It should be completed within an elapsed time of approximately 2 ½ minutes.

Immediately measure the slump determining the difference between height of the mold and height over the displaced original center of the top surface of the specimen. Slump is measured to the nearest ¼ inch of subsidence below top of the mold.

**A record of each slump test performed should be recorded in Site Manger.**

# **AASHTO T152**

ASTM C231

## **Air Content of Freshly-Mixed Concrete by the Pressure Method**

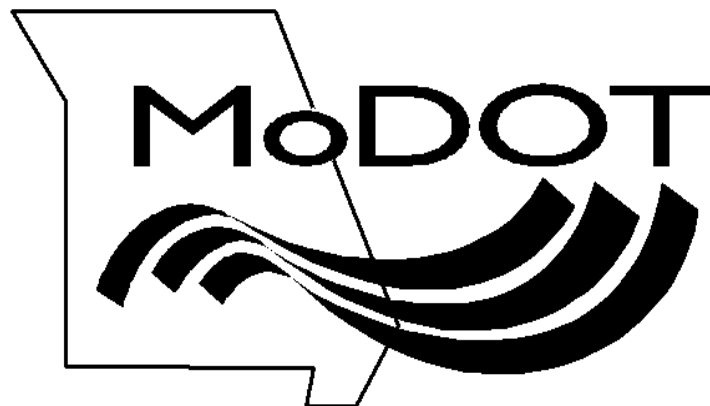



# AASHTO T152



## Air Content of Freshly Mixed Concrete by the Pressure Method

Revised 10/22/2024

1

---

---

---

---

---

---

---

---

### SCOPE

- This method covers determination of the air content of freshly mixed concrete from observation of the change in volume of concrete with a change in pressure.
- Having the correct amount of air in the mix makes the concrete more durable and more resistant to freezing and thawing. Too much air reduces the durability and compressive strength, too little air reduces the durability.

2

2

---

---

---

---

---

---

---

---

### SIGNIFICANCE AND USE

- This test method covers the determination of the air content of freshly mixed concrete.
  - The test determines the air content of freshly mixed concrete exclusive of any air that exists inside voids within aggregate particles.
  - For this reason, it is applicable to concrete made with relatively dense aggregate particles and requires determination of an aggregate correction factor.
- **NOTE:** Concrete with light weight aggregates or aggregates with high porosity may NOT be tested by this method – use AASHTO T196

3

3

---

---

---

---

---

---

---

---

- The three AASHTO methods that provide **gravimetric**, **volumetric**, and **pressure** procedures, respectively, for determining the air content of freshly mixed concrete are:

**1. AASHTO T152**

Air Content by *pressure* testing

- Uses an Air Meter Type A or B
- For Dense aggregate
- Uses a correction factor for the air inside of aggregates

Significance and Use

4

4

---

---

---

---

---

---

---

---

**2. AASHTO T121M**

Air Content by *gravimetric* testing

- Uses a Unit Measure for density
- For "Yield" and "Air" content of concrete

**3. AASHTO T196M**

Air Content by *volumetric* testing

- Uses a Volumetric Air Meter (Roll-a-Meter)
- For all types of aggregate
- Is not affected by air inside of aggregates

Significance and Use

5

5

---

---

---

---

---

---

---

---

**NOTE:**

- The pressure procedure (AASHTO T152) gives substantially the same air content as the other two test methods for concrete made with dense aggregates.
- The air content of hardened concrete may be either higher or lower than that determined by this test method. This depends on the methods and amount of consolidation effort applied to the concrete from which the hardened concrete specimen is taken.

Significance and Use

6

6

---

---

---

---

---

---

---

---



- Items that affect the air content in hardened concrete:
  - A. Uniformity and stability of the air bubbles in the fresh and hardened concrete
  - B. Time of comparison
  - C. Environmental exposure
  - D. The stage in delivery
  - E. Placement
  - F. Consolidation processes at which the air is determined, that is, before or after the concrete goes through a pump; and other factors.

Significance and Use

7

7

---

---

---

---

---

---

---

---

- |  |  |           |
|--|--|-----------|
| <ul style="list-style-type: none"> <li>• Air Meter Type A or B (Typical vol. is 0.25 ft<sup>3</sup>)</li> <li>• Tamping rod           <ul style="list-style-type: none"> <li>- 5/8 ± 1/16" x 20 ± 4"</li> </ul> </li> <li>• Mallet           <ul style="list-style-type: none"> <li>- Rubber or Rawhide head.</li> <li>- Wt. ~1.25 ± 0.50lb.               <ul style="list-style-type: none"> <li>• For measures of 0.5ft<sup>3</sup> or smaller</li> </ul> </li> <li>- Wt. ~2.25 ± 0.50lb.               <ul style="list-style-type: none"> <li>• For measures larger than 0.5ft<sup>3</sup></li> </ul> </li> </ul> </li> <li>• Vibrator</li> <li>• Scoop or shovel <span style="background-color: yellow;">updated</span></li> </ul> | <ul style="list-style-type: none"> <li>• Water Supply</li> <li>• Strike off steel bar           <ul style="list-style-type: none"> <li>- 1/8" thick, 3/4" wide, 12" long</li> </ul> </li> <li>• Strike off plate           <ul style="list-style-type: none"> <li>- Flat rectangular               <ul style="list-style-type: none"> <li>• Metal 1/4" thick</li> <li>• Glass or acrylic ≥ 1/2" thick</li> </ul> </li> <li>- Length ≥ 2" of the diameter of the measure</li> <li>- Edges straight and smooth</li> </ul> </li> <li>• Rubber syringe, Plastic wash bottle</li> </ul> | EQUIPMENT |
|--|--|-----------|

8

8

---

---

---

---

---

---

---

---

**Internal Vibrators:**

- ≥ 9000 vpm (150hz) while in operation
  - Check periodically with a vibrating – reed tachometer
- Vibrator element must be ≤ 1/4 of the diameter of the cylinder mold or beam width
- Combined length of vibrator element and shaft ≥ 3" longer than depth of section being vibrated.



Equipment

9

9

---

---

---

---

---

---

---

---

**External Vibrators:**

- The two types of external vibrators permitted are either table or plank.
- The external vibrator frequency shall be 3600 vpm (60Hz) or higher.



Equipment

10

10

---

---

---

---

---

---

---

---

**Type A Air-Meters**



More information can be found in the Appendix.

Apparatus

11

11

---

---

---

---

---

---

---

---

**Type "B" Air-Meters**

Covered in this certification



More information on equipment can be found in the Appendix.

Apparatus

12

12

---

---

---

---

---

---

---

---

### Diagram of a Type "B" Air-Meter

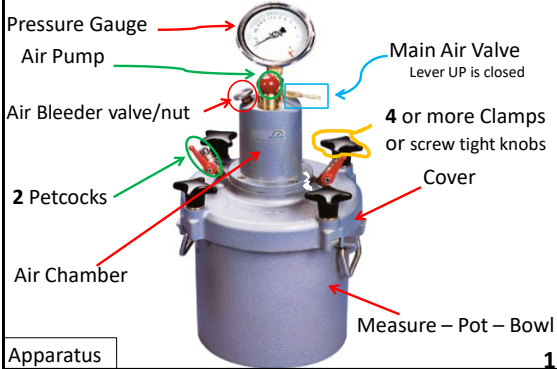

Apparatus

13

13

---

---

---

---

---

---

---

---

### Horizontal Type B Air-Meter

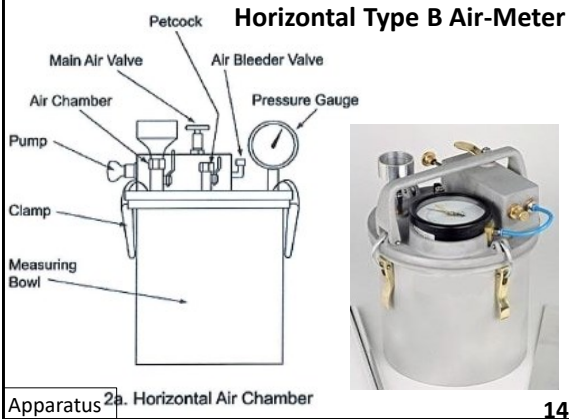

Apparatus

2a. Horizontal Air Chamber

14

14

---

---

---

---

---

---

---

---

### CALIBRATION/STANDARDIZATION OF APPARATUS



15

15

---

---

---

---

---

---

---

---

- Unless otherwise specified, follow the requirements and intervals for equipment calibrations, standardizations, and checks in AASHTO R 18, and procedures in AASHTO R 61.
- Rough handling will affect the standardization of both type A and Type B meters. Barometric pressure will affect the standardization of only type A meter.

Calibration of Apparatus

16

16

---

---

---

---

---

---

---

---

• **Annual Calibration must be performed at 5% Air.**

– The quick field check using 1.2% air is **NOT** acceptable as calibration on horizontal gauges.



Calibration of Apparatus

17

17

---

---

---

---

---

---

---

---



5%



**See Annex and MoDOT EPG for more information on Calibration and Standardization.**

Calibration of Apparatus

18

18

---

---

---

---

---

---

---

---

## Calibration of Air Meter – Video

updated 10/22/24 <https://youtu.be/Qu03gynuFk0?si=HMz8abqP-xbtUawb>



Updated Video

19

---

---

---

---

---

---

---

---

## Air Meter Check

- If needed for a spot check in-between the annual calibration, use one of the “**Air Meter Calibrators (5%)**” below.
- **Verify the calibrator with the calibration of the Air Meter. In comparing results, note if there is a small off-set to apply to the calibrator.**

Follow manufacturers instructions on how to use these devices.



Calibration of Apparatus

20

20

---

---

---

---

---

---

---

---

- **Calibration/Standardization Records** – Information to be maintained in the records shall include determination of expansion factor, size of the standardization vessel used, and the reading of the meter at the standardization test point(s).

Calibration of Apparatus

21

21

---

---

---

---

---

---

---

---

**DETERMINATION  
OF THE  
AGGREGATE CORRECTION FACTOR**



22

22

---

---

---

---

---

---

---

---

**Procedure** – Determine the aggregate correction factor on a combined sample of fine and coarse aggregate. It is determined independently by applying the standardized pressure to a sample of fine and coarse aggregate covered in water in approximately the same moisture condition, amount, and proportions occurring in the concrete sample under test.

**Aggregate Sample Size** – Calculate the weights of fine and coarse aggregate present in the sample of fresh concrete whose air content is to be determined, as follows:

Aggregate Correction Factor

23

23

---

---

---

---

---

---

---

---

Aggregate Correction Factor – Fine Aggregate

$$F_s = \frac{S \times F_b}{B}$$

**F<sub>s</sub>** = weight of the fine aggregate used in the aggregate correction factor test, in pounds.

**S** = volume of the air meter measuring bowl; for MoDOT gauges **0.25** cubic feet.

**B** = volume of concrete produced per batch, this should be 27 cubic feet (1 cubic yard).

**F<sub>b</sub>** = total weight of fine aggregate used in one cubic yard of concrete. This will be the scale weight, in lbs., taken from the pouring report.

24

24

---

---

---

---

---

---

---

---

Aggregate Correction Factor – Coarse Aggregate

$$C_s = \frac{S \times C_b}{B}$$

C<sub>s</sub> = weight of the coarse aggregate used in the aggregate correction factor test, in pounds.

S = volume of the air meter measuring bowl; for MoDOT gauges **0.25** cubic feet.

B = volume of concrete produced per batch; this should be 27 cubic feet (1 cubic yard).

C<sub>b</sub> = total weight of coarse aggregate used in one cubic yard of concrete. This will be the scale weight, in lbs., taken from the pouring report.

25

25

---

---

---

---

---

---

---

---

**Placement of Aggregate in the Measuring Bowl**

- Mix representative samples of fine aggregate F<sub>s</sub> and coarse aggregate C<sub>s</sub>, and place in the measuring bowl filled one-third full of water.
- Place the mixed aggregate, a small amount at a time, into the measuring bowl; if necessary, add additional water to submerge all of the aggregate.
- Add each scoopful in a manner that will entrap as little air as possible and remove accumulations of foam promptly.
- Tap around the perimeter of the measuring bowl and lightly rod the upper 1 inch of the aggregate about 8-12 times. Stir after each addition of aggregate to eliminate entrapped air.

26

---

---

---

---

---

---

---

---

**Initial Procedure for Type A and Type B Meters**

- After all the aggregate is in the measuring bowl, remove excess foam and keep the aggregate covered in water for a period of time approximately equal to the time between introduction of the water into the mixer and the time of performing the test for air content before proceeding with the determination as directed per AASHTO T152.

Aggregate Correction Factor

27

27

---

---

---

---

---

---

---

---

**Type A Meter** – Complete the test for the Determination of Aggregate Correction Factor as described in the Appendix.

**Type B Meter** – Perform the procedure for Determining Air Content.

Remove a volume of water from the assembled and filled apparatus approximately equivalent to the volume of air that would be contained in a typical concrete sample. (generally 5%) See Annex A1.9 for this procedure.

Aggregate Correction Factor

28

28

---

---

---

---

---

---

---

---

### Classroom Exercise

- Given Scale weights from Concrete Mix Design:

Fine Aggregate – 1281 lbs./yd.<sup>3</sup>

Coarse Aggregate – 1843 lbs./yd.<sup>3</sup>

- Report** both the weight of Fine and Coarse aggregate to the nearest **0.01 pound**, used to determine Aggregate Correction Factor.

Aggregate Correction Factor

29

29

---

---

---

---

---

---

---

---

### Classroom Exercise

Determine the weight of the coarse and fine aggregate that will be in the air meter for testing using the following formulas to calculate the weights.

Fine Agg.  $F_S = \frac{S \times F_b}{B}$  OR  $F_s = (S/B) \times F_b$

Coarse Agg.  $C_S = \frac{S \times C_b}{B}$  OR  $C_s = (S/B) \times C_b$

Aggregate Correction Factor

30

30

---

---

---

---

---

---

---

---



Classroom  
Exercise

$$F_b = 1281 \text{ lb. yd}^3$$
$$C_b = 1843 \text{ lb. yd}^3$$
$$S = 0.25$$
$$B = 27$$

*Answer*

S = Volume of the air meter measuring bowl; for MoDOT gauges 0.25 cubic feet.

B = Volume of concrete produced per batch; this should be 27 cubic feet (1 cubic yard).

$$F_s = \frac{0.25 \times 1281}{27} = 11.861 = \mathbf{11.86 \text{ lb.}}$$

$$C_s = \frac{0.25 \times 1843}{27} = 17.064 = \mathbf{17.06 \text{ lb.}}$$

Report the answer to nearest **0.01 lb.**

**31**

31

---

---

---

---

---

---

---

---

## MoDOT

### EPG Section 501

Air tests are to be made at the beginning of each pour on structures and for each 100 cubic yards there after.

Aggregate correction factors shall be made available by the district to the Central laboratory when coarse aggregate samples are submitted for AASHTO T161 testing – Cycles of Freezing and thawing – test for durability.

NOTE: See the EPG for additional information on MoDOT practices for testing Air Content of Concrete.

**32**

32

---

---

---

---

---

---

---

---

## PREPARATION AND PROCEDURE FOR DETERMINING AIR CONTENT OF CONCRETE



**33**

33

---

---

---

---

---

---

---

---

## **PREPARATION**

- Obtain a sample of freshly mixed concrete in accordance with applicable procedures of AASHTO R 60.



34

34

---

---

---

---

---

---

---

---

- If the concrete contains coarse aggregate particles that would be retained on a 2-inch sieve, wet-sieve a sufficient amount of the representative sample over a 1½ inch sieve, as described in AASHTO R60, to yield somewhat more than enough material to fill the measuring bowl of the size selected for use.
- Take caution to minimize disturbing the mortar when wet sieving.

Preparation

35

35

---

---

---

---

---

---

---

---

## **PROCEDURE**

- **Dampen the interior** of the measuring bowl and place it on a flat, level, firm surface.



36

36

---

---

---

---

---

---

---

---

**Place a representative sample** of concrete in the measuring bowl in **3** equal layers using a scoop.



Procedure 37

37

---

---

---

---

---

---

---

---

• **Consolidate each layer by rodding or by vibration.**

A slump greater than **3** inches = **ROD**

A slump of **1** to **3** inches = **ROD or VIBRATE**

A slump less than **1** inch = **VIBRATE**

**NOTE:** Self-Consolidating Concrete (SCC) prohibits rodding and internal vibration, so slightly overfill the measure with SCC in one continuous lift.

Procedure 38

38

---

---

---

---

---

---

---

---

### Consolidation by Rodding

- When rodding the concrete, place the concrete in three equal layers. Rod each layer 25 times with the tamping rod.
- The strokes should be evenly dispersed across the area of the concrete.



Procedure - Rodding 39

39

---

---

---

---

---

---

---

---

- Rod the **bottom layer** throughout its depth, but do not forcibly strike the bottom of the bowl.
- When rodding the **second and final layers** only allow the rod to penetrate the previous layer about 1 inch.
- When the **final layer** of concrete is added, be careful to avoid excessive overfilling. ( $\frac{1}{8}$  inch is optimum)



Procedure - Rodding **40**

40

---

---

---

---

---

---

---

---

• **Tap the side with a mallet.**

- After each layer is rodded, sharply tap the side of the bowl with the mallet 10 to 15 times. This will close the voids left by the tamping rod and will release any entrapped air.



Procedure - Rodding **41**

41

---

---

---

---

---

---

---

---

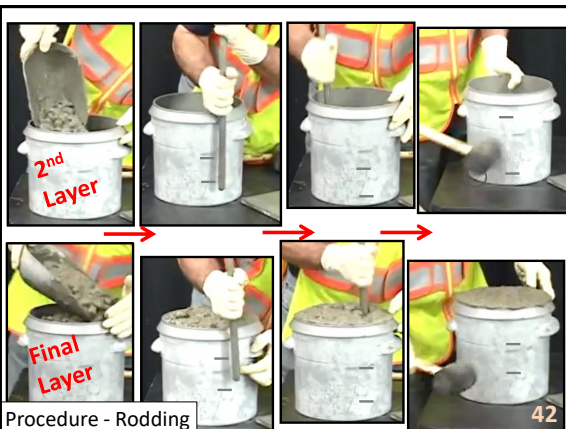

Procedure - Rodding **42**

42

---

---

---

---

---

---

---

---

## Consolidation by Vibrating

When vibrating the concrete, place the concrete in **2** approximately equal layers.

- Vibrate each layer by inserting the vibrator in **3 places** evenly dispersed across the area of the concrete.
- Avoid excessive overfilling with the final layer.
- When vibrating the bottom layer, do not let the vibrator touch the bottom or sides of the bowl.

Procedure - Vibrating

43

43

---

---

---

---

---

---

---

---

- Always be careful when removing the vibrator so that air voids are not left in the concrete.
- Do not over vibrate the concrete.
- Vibration should stop when the concrete becomes relatively smooth and has a glazed appearance.

If froth begins to form on top of the concrete, then the concrete has been vibrated too long. Redo the test.



Procedure - Vibrating

44

44

---

---

---

---

---

---

---

---

## CONSOLIDATION SUMMARY

### Rodding

3 layers  
25 strokes/layer  
10–15 sharp taps/layer



Procedure

### Vibration

2 layers  
3 insertions per layer  
Evenly distributed over cross section



45

45

---

---

---

---

---

---

---

---

• **Strike Off**

• After consolidation, Strike Off the top surface with the strike off bar using a sawing motion until the bowl is just level full. Removal of approximately 1/8 inch is optimum.

- A small quantity of concrete may be added to fill any voids in the surface.
- Large excesses of concrete should be removed with a scoop before the strike off.



**Do Not** use the tamping rod to strike off the bowl.

Procedure

46

46

---

---

---

---

---

---

---

---

• **Clean the rims** of the bowl and cover.

- To ensure a tight pressure seal is made when the cover is placed on the bowl.



• **Moisten the bottom of the cover**

• **Secure the cover** on the bowl.



Procedure

47

47

---

---

---

---

---

---

---

---

• **Close the air valve** between the air chamber and the measuring bowl and open both petcocks on the holes through the cover.



• **Introduce water** through one petcock until it comes out the opposite petcock.



48

48

---

---

---

---

---

---

---

---

- **Jar the meter** gently until all air is expelled from this same petcock.



Procedure

49

49

---

---

---

---

---

---

---

---

- **Pump air into the air chamber** until the gauge hand is on the initial pressure (IP) line.

- » IP is found written on the dial face
- » IP marks are below 0%

- **Wait a few seconds**

for the gauge to stabilize at the initial gauge line.



50

50

---

---

---

---

---

---

---

---

Air Content of Concrete by the Pressure Method

Example on dial I/P = 3

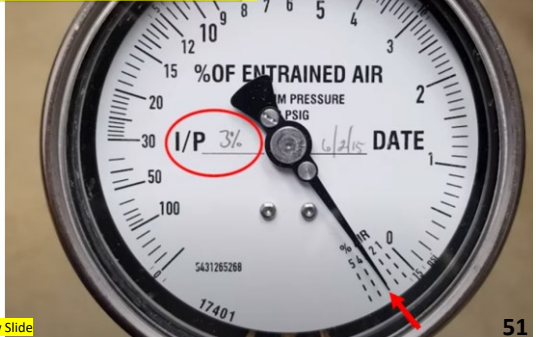

New Slide

51

51

---

---

---

---

---

---

---

---



• **Tap the gauge lightly** with fingers until reading stabilizes.

• **Adjust air to initial pressure line.**

– Bleed air off by loosening the air bleeder nut.

– Pump additional air if needed.

– Tap gauge lightly after adjustments.

• **Close both petcocks.**



Procedure

52

52

---

---

---

---

---

---

---

---



• **Open the air valve** between the air chamber and the measuring bowl.

• **Tap the sides** of the measuring bowl sharply with the mallet to relieve local restraints.

Procedure

53

53

---

---

---

---

---

---

---

---

• **Lightly tap the pressure gauge** by hand and read the percentage of air on the dial of the pressure gauge.

• This reading **minus the aggregate correction factor** is the air content of the concrete mixture.



Procedure

54

54

---

---

---

---

---

---

---

---



## CALCULATION – AIR CONTENT

- Calculate the air content of the concrete in the measuring bowl as follows:

$$A_s = A_1 - G$$

$A_s$  = Air content of sample tested, percent.

$A_1$  = Apparent Air content of the sample tested, percent.

$G$  = Aggregate correction factor, percent.

55

55

---

---

---

---

---

---

---

---

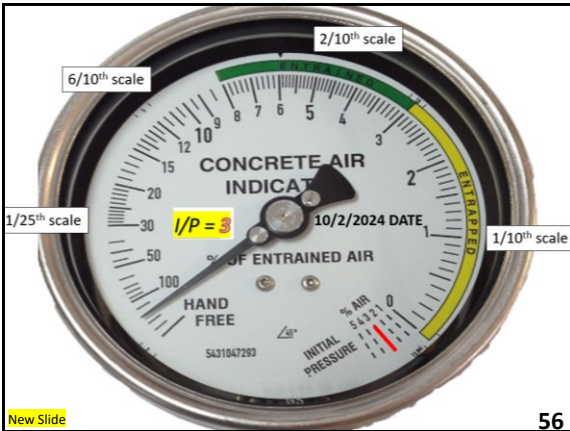

New Slide

56

56

---

---

---

---

---

---

---

---

## Reading the Percent Air

- Air Content  $\leq 8.0\%$ 
  - Report to nearest 0.1%
- Air Content  $> 8.0\%$ 
  - Report to nearest half-scale division

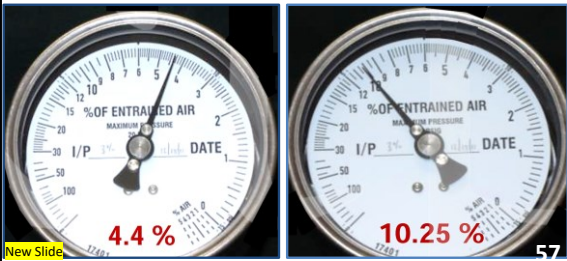

New Slide

57

57

---

---

---

---

---

---

---

---

## REPORT

Report the air content of the concrete sample to the **nearest 0.1 percent** after subtracting the aggregate correction factor, unless the gauge reading of the meter **exceeds 8 percent**, in this case the corrected reading shall be reported to the **nearest 1/2 scale** division on the dial.

Example, to the nearest 0.1% or 0.5%.

Report the date and time of the test

(For MoDOT See EPG Section 501.1.8.2.)

58

58

---

---

---

---

---

---

---

---

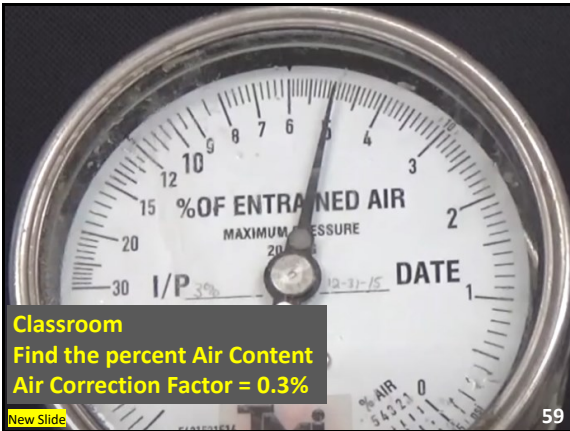

Classroom  
Find the percent Air Content  
Air Correction Factor = 0.3%

New Slide

59

59

---

---

---

---

---

---

---

---

### Air Content Calculation

Air% = Gauge Reading – Aggregate Correction Factor

#### **Example:**

ACF = 0.3%

Gauge Reading = 5.0%

Air% = 5.0% – 0.3

Air% = 4.7%

New Slide

60

60

---

---

---

---

---

---

---

---

**On your own**

Using the following information, what three items would be reported for air content per AASHTO T152? Report air to the correct decimal place.

**Air Content Reading, job information:**

Taken on: 05/24/2024 at 10 AM,  
Producer/Supplier: ABC Concrete Producers LLC  
Job#: Jen8675309  
Location: 830 MoDOT Drive, Jefferson City MO. 65102  
Slump: 4.00 inches  
Air-Content pressure gauge reading: *\_gauge on next slide\_*  
Aggregate Correction Factor: 0.3%

- 1. \_\_\_\_\_
- 2. \_\_\_\_\_
- 3. \_\_\_\_\_

New Slide

61

---

---

---

---

---

---

---

---

61

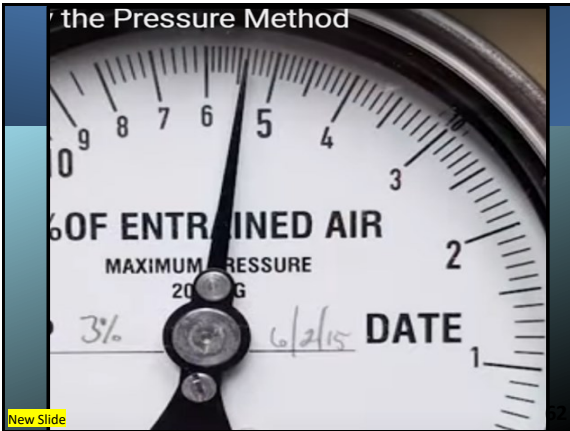

New Slide

62

---

---

---

---

---

---

---

---

**Common Testing Errors:**

- Failure to close the main air valve before releasing the pressure from either the container or the air chamber will result in water being drawn into the air chamber, thus introducing error in subsequent measurements.
- Not having a tight pressure seal between the cover and the bowl due to not cleaning the rim of the pot or meter top.
- Not tapping the pot between layers.
- Not rodding or vibrating each layer.

63

63

---

---

---

---

---

---

---

---



**ANNEX****(Mandatory Information)****A1—STANDARDIZATION OF APPARATUS**

**A1.1 – Standardization tests** shall be performed in accordance with the following procedures as applicable to the meter type being employed.

**A1.2 – standardization of the standardization vessel** – Determine accurately the weight of water required to fill the standardization vessel,  $w$ , using a scale accurate to 0.1 percent of the weight of the vessel filled with water. This step shall be performed for Type A and Type B meters.

**A1.3 – Standardization of the Measuring Bowl** – Determine the weight of water required to fill the measuring bowl,  $W$ , using the scale accurate to 0.1 percent of the weight of the measuring bowl filled with water. Slide a glass plate carefully over the flange of the measuring bowl in a manner to ensure that the measuring bowl is completely filled with water. A thin film of cup grease smeared on the flange of the measuring bowl will make a water tight joint between the glass plate and the top of the measuring bowl. This step shall be performed for Type A and Type B meters.

**A1.4 – Effective volume of the Standardization Vessel,  $R$**  – The constant  $R$  represents the effective volume of the standardization vessel expressed as a percentage of the volume of the measuring bowl.

**A1.4.1—For A meters**, calculate  $R$  as follows (Note A1) :

$$R = 0.98 w/W$$

Where:

$w$  = weight of water required to fill the standardization vessel,

$W$  = weight of water required to fill the measuring bowl.

**Note A1:** the factor 0.98 is used to correct for the reduction in the volume of air in the standardization vessel when it is compressed by a depth of water equal to the depth of the measuring bowl. The value of this constant will decrease by about 0.01 for each 4 inches increase in measuring bowl depth. The depth of the measuring bowl and atmospheric pressure do not affect the effective volume of the B Type meters.

**A1.4.2-- For Type B meters**, calculate  $R$  as follows:  $R = w/W$

**A1.5—Determination of, or Check of, Allowance for Expansion Factor,  $D$**

**A1.5.1** For **Type A meter**, determine the expansion factor,  $D$  (note A2) by filling the apparatus with water only (making certain that all entrapped air has been removed and the water level is exactly on the zero mark (Note A3) and applying an air pressure approximately equal to the operating pressure,  $P$ , determined by the standardization test described in Section A1.7 the amount the water column lowers will be the equivalent expansion factor,  $D$ , for that particular apparatus and pressure (Note A4).

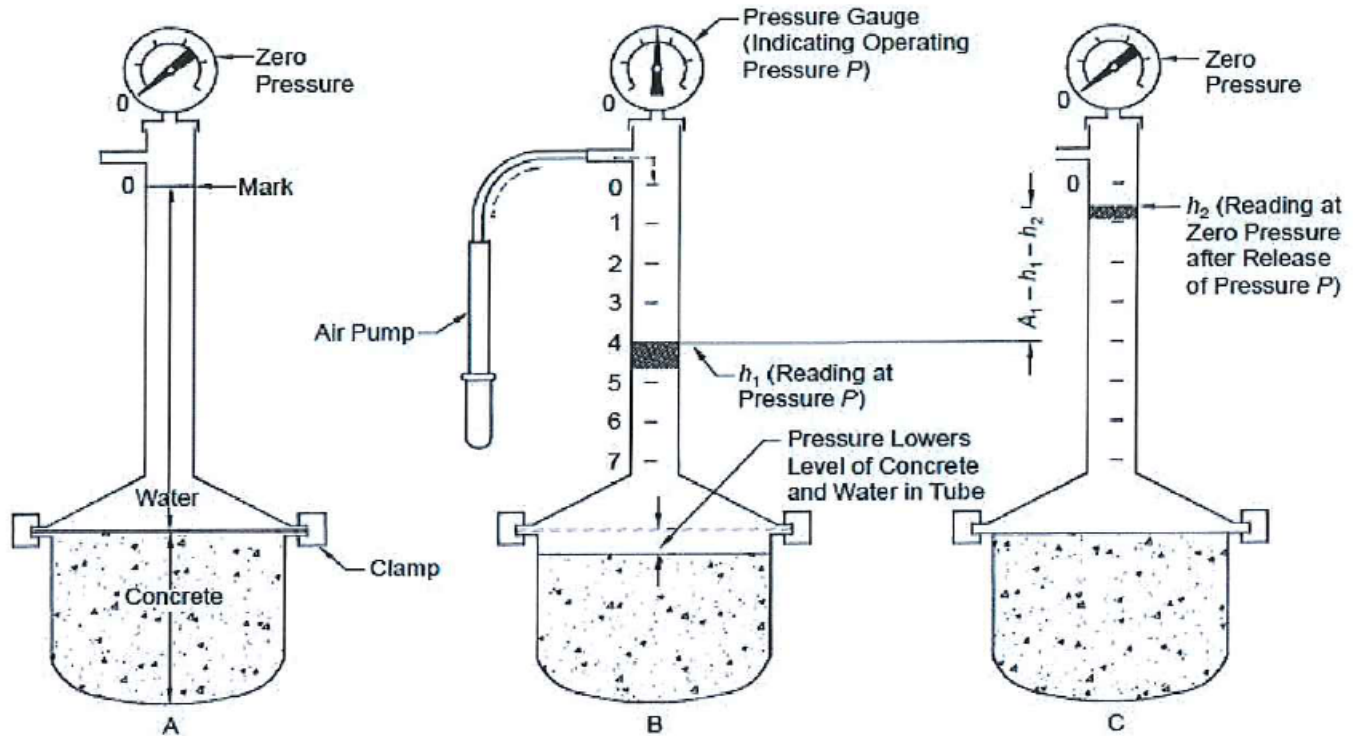

Note:  $A_1 = h_1 - h_2$  when measuring bowl contains concrete as shown in this figure; when measuring bowl contains only aggregate and water,  $h_1 - h_2 = G$  (aggregate correction factor).  
 $A_1 - G = A$  (entrained air content of concrete).

**Figure 1**—Illustration of the Pressure Method for Air Content: Type A Meter

**Note A2** – The application of internal pressure will result in a small increase in volume. This expansion will not affect the test results because, with the procedure described in Section s6 and 8, the amount of expansion is the same for the test and as for the correction factor, and is thereby automatically cancelled. However, it does enter into the standardization test to determine the air pressure to be used in testing fresh concrete.

**Note A3**—The water columns on some meters of Type a design are marked with an initial water level and a zero mark, the difference between the two marks being the allowance for the expansion factor. This allowance should be checked in the same manner as for meters not so marked and in such a case, the expansion factor should be omitted in computing the standardization readings in section A1.7

**Note A4**—It will be sufficiently accurate for this purpose to use an approximate value for P determined by making a preliminary standardization test as described in Section A1.7 except that an approximate value for the standardization factor, K, should be used. For this test  $K = 0.98R$  which is the same as Equation A1.2 except that the expansion reading, d, as yet unknown, is assumed to be zero.

**A1.5.2**—For **meters of Type B**, the allowance for the expansion factor, D, is included in the difference between the initial pressure indicated on the pressure gauge and the zero percent mark on the air-content scale on the pressure gauge. This allowance shall be checked by filling the apparatus with water (making certain that all entrapped air has been removed), pumping air into the air chamber until the gauge hand is stabilized at the indicated initial pressure line, and then releasing the air to the measuring bowl (Note A5). If the initial pressure line is correctly positioned, the gauge should read zero percent. The initial pressure line shall be adjusted if two or more determinations show the same variation from zero percent and the test repeated to check the adjusted initial pressure line.

**Note A5**—this procedure may be accomplished in connection with the standardization test described in Section A1.9.

**A1.6-- standardization Reading K** – The standardization reading, K, is the final meter reading to be obtained when the meter is operated at the correct standardization pressure.

**A1.6.1**—for **Type A meters**, the standardization reading, K, is as follows:

$$K = R + D$$

Where:

**R** = effective volume of the standardization vessel (Section a1.4.1),

**D** = expansion factor (Section a1.5.1 and Note A6)

**A1.7—Standardization Test to Determine Operating Pressure, P, on Pressure Gauge, Type A meter** – If the rim of the standardization cylinder contains no recesses or projections, fit it with three or more spacers equally spaced around the circumference. Invert the cylinder and place it at the center of the dry bottom of the measuring bowl. The spacers will provide an opening for flow of water into the standardization cylinder when pressure is applied.

**A1.7.1**—Secure the inverted cylinder against displacement and carefully lower the cover assembly. After the cover is clamped in place, carefully adjust the apparatus assembly to a vertical position and add water at air temperature, by means of the tube and funnel, until it rises above the zero mark on the standpipe. Close the vent and pump air into the apparatus to the approximate operating pressure.

**A1.7.2**—Incline the assembly about 30 degrees from vertical and, using the bottom of the measuring bowl as a pivot, describe several complete circles with the upper end of the standpipe, simultaneously tapping the cover and sides of the measuring bowl lightly to remove any entrapped air adhering to the inner surfaces of the apparatus. Return the apparatus to a vertical position, gradually release the pressure (to avoid loss of air from the standardization vessel) and open the vent.

**A1.7.3**—Bring the water level exactly to the zero mark by bleeding water through the petcock in the top of the conical cover. After closing the vent, apply pressure until the water level has dropped an amount equivalent to about 0.1 to 0.2 percent of air more than the value of the standardization reading,  $K$ , determined as described in Section A1.6. To relieve local restraints, lightly tap the sides of the measuring bowl and when the water level is exactly at the value of the standardization reading,  $K$ , read the pressure,  $P$ , indicated by the gauge and record to the nearest 0.1 psi.

**A1.7.4**—Gradually release the pressure and open the vent to determine whether the water level returns to the zero mark when the side of the measuring bowl is tapped lightly (failure to do so indicates loss of air from the standardization vessel or loss of water due to a leak in the assembly). If the water level fails to return to within 0.05 percent air of the zero mark and no leakage beyond a few drops of water is found, some air probably was lost from the standardization cylinder. In this case, repeat the standardization procedure step-by-step from the beginning of this paragraph. If the leakage is more than a few drops of water, tighten the leaking joint before repeating the standardization procedure.

**A1.7.5**—check the indicated pressure reading promptly by bringing the water level exactly to the zero mark, closing the vent, and applying pressure,  $P$ , just determined. Tap the gauge lightly with a finger. When the gauge indicates the exact pressure,  $P$ , the water column should read the value of the standardization factor,  $K$ , used in the first pressure application, within about 0.05% of air.

**Note A7**—CAUTION—The apparatus assembly should not be moved from the vertical position until pressure has been applied that will force water about one third of the way up into the standardization cylinder. Any loss of air from this cylinder will nullify the standardization.



**A1.8—Standardization Test to determine alternative Operating Pressure P1 – Type A Meter** – the range of air contents that can be measured with a given meter can be doubled by determine an alternative operating pressure P1 such that the meter reads half of the standardization reading, K, (equation A1.3). Exact standardization will require determination of the expansion factor at the reduced pressure in Section A1.5. for most purposes, the change in expansion factor can be disregarded and the alternative operating pressure determined during the determination of the regular operating pressure in section A1.7.



**A1.9—Standardization Test to Check the Air Content Graduations of the Pressure Gauge, Type B Meter**—Fill the measuring bowl with water as described in Section A1.3. Screw the short piece of tubing or pipe furnished with the apparatus into the threaded petcock hole on the underside of the cover assembly. Assemble the apparatus. Close the air valve between the air chamber and the measuring bowl and open the two petcocks on holes through the cover assembly. Add water through the petcock on the cover assembly, leaving the short piece of tubing or pipe extension in place until all air is expelled from the second petcock.

**A1.9.1**—Pump air into the air chamber until the pressure reaches the indicated initial pressure line. Allow a few seconds for the compression air to cool to normal temperature. Stabilize the gauge hand at the initial pressure line by pumping or bleeding off air as necessary, tapping the gauge lightly.



Close the petcock not provided with the tube or pipe extension on the underside of the cover. Remove water from the assembly to the calibrating vessel controlling the flow, depending on the particular meter design, by opening the petcock provided with the tube or pipe extension and cracking the air valve between the air chamber and the measuring bowl or by opening the air valve and using the petcock to control flow.

**A1.9.2**—Perform the standardization at an air content that is within the normal range of use. If the standardization vessel (Section A1.2) has a capacity within the normal range of use, remove exactly that amount of water. With some meters, the calibrating vessel is quite small and it will be necessary to remove several times that volume to obtain an air content within the normal range of use. In this instance, carefully collect the water in an auxiliary container and determine the amount removed by weighing to the nearest 0.1%.

**A1.9.3**—Calculate the correct air content,  $R$ , by using Equation A1.2. Release the air from the apparatus at the petcock not used from filling the standardization vessel and if the apparatus employs an auxiliary tube for filling the standardization container, open the petcock to which the tube is connected to drain the tube back into the measuring bowl (Note A7). At this point of the procedure, the measuring bowl contains the percentage of air determined by the standardization test of the calibrating vessel.

**A1.10**—Pump air into the air chamber until the pressure reaches the initial pressure line marked on the pressure gauge, close both petcocks in the cover assembly, and then open the valve between the air chamber

and the measuring bowl. The indicated air content on the pressure gauge dial should correspond to the percentage of air determined to be in the measuring bowl. If two or more determinations show the same variation from the correct air content, the dial hand shall be reset to the correct air content and the test repeated until the gauge reading corresponds to the standardized air content within 0.1%. If the dial hand was reset to obtain the correct air content, recheck the initial pressure mark as in Section A1.5.2. If a new initial pressure reading is required, repeat the standardization to check the accuracy of the graduation on the pressure gauge described earlier in this section. If difficulty is encountered in obtaining consistent readings, check for leaks, for the presence of water inside the air chamber (Figure 2), or the presence of air bubbles clinging to the inside surfaces of the meter from the use of cool, aerated water. In this latter instance, use deaerated water, this can be obtained by cooling hot water to room temperature.

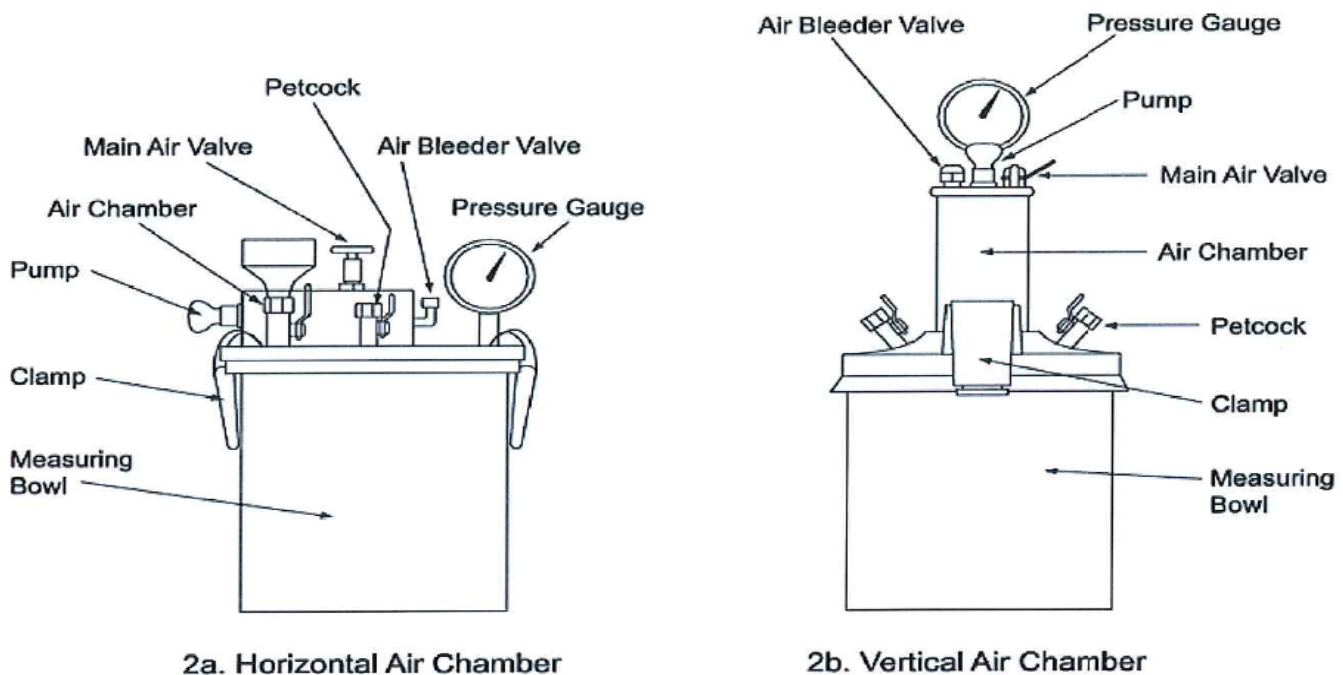

**Figure 2**—Schematic Diagram: Type B Meter

Note A8—If the calibrating vessel is an integral part of the cover assembly, the petcock used in filling the vessel should be closed immediately after filling the standardization vessel and not opened until the test is complete.

### **Air entrainment tests by the pressure method**

Test methods outlined in the following paragraphs were derived from AASHTO T-152 to provide a basis for determining air content of freshly mixed concrete. Principles involved are based on the fact that air is the only compressible component in freshly mixed concrete. Operation of testing equipment is to be in accordance with the manufacturer's instructions.

The pressure method of determining air entrainment is to be used for concrete intended for both structures and pavement, with the exception of lightweight concrete. Porosity of lightweight aggregates introduces errors into results which make other procedures necessary.

Air test are to be made at the beginning of each pour on structures and for each 100 cubic yards thereafter.

Equipment used to determine the air content of concrete shall meet the requirements of AASHTO T-152. All types of apparatus used for determining air content by the pressure method have several features in common.

- (a) A measuring bowl which is sufficiently rigid to make a pressure tight container of accurate volume and which is suitable to hold a representative sample of the concrete to be tested.
- (b) A cover which is designed to be attached to the measuring bowl in a way which produces a rigid, pressure-tight assembly.
- (c) Means of applying a known pressure to the system, and for observing its effect on the volume of the sample.
- (d) Appropriate tools for placing and consolidating the sample and using the apparatus. A tampering rod 5/8 inch in diameter with a hemispherical tip is furnished for compacting concrete. This rod should be approximately 2 feet in length. A mallet with a rubber or rawhide head weighing approximately ½ lb. is furnished for tapping the measuring bowl during the testing process. Other accessories such as a trowel, strike-off bar, funnel, and water measure are part of the set.

The following procedures for calibration of the apparatus, determination of air content of concrete, and calculations of results will be given in general terms since minor changes are necessary for different types of apparatus. However, the intent will serve as a guide to exact procedures to be used if equipment furnished is slightly different.

Aggregate correction factors shall be made available by the district to the Central Laboratory when coarse aggregate samples are submitted for AASHTO T161 testing.

**501.1.8.1 Calibration**

**Protex Meter.** Calibration of pressure-type apparatus is affected by changes in barometric pressure such as those caused by changes of temperature and humidity, and by rough handling. Steps (a) through (e) normally need to be made only at time initial calibration, and occasionally there after to check the stability of volume for the calibration cylinder and measuring bowl. Step (f) must be made as frequent as necessary to insure that proper gauge pressure is being used in tests for air content of concrete.

- (a) Calibration of the calibration cylinder. Accurately determine weight of water,  $w$ , in grams required to fill the calibration cylinder, using a scale sensitive to 0.5 gram.
- (b) Calibration of measuring bowl. Determine weight of water,  $W$ , (in pounds) required to fill the measuring bowl. Use a scale sensitive to 0.1 percent of the weight of the bowl filled with water. Slide a glass plate carefully over the flange of the bowl in a way to insure that the bowl is completely filled with water. A Thin film of cup grease smeared on the flange of the bowl will make a water tight joint between the glass and the top of the bowl.
- (c) Determination of Constant,  $R$ . The Constant,  $R$ , represents the volume of the calibration cylinder expressed as a percentage of the volume of the measuring bowl. Calculate  $R$  by the following equation:

$$R = \frac{0.2205w(\text{grams})}{W(\text{pounds})}$$

If the scales of adequate capacity are available and the inspector so desires,  $W$  may be determined in grams. If that is done the equation reduces to:

$$R = \frac{w(\text{grams})}{W(\text{grams})}$$

- (d) Determination of the expansion factor,  $D$ . Determine the expansion factor,  $D$ , for any giving apparatus assembly by filling the apparatus with only water. Make certain that all entrapped air has been removed and that the water level is exactly on the zero mark. Apply an air pressure approximately equal to the operating pressure,  $P$ , determined by the calibration test described in (f). The amount the water column lowers will be the equivalent expansion factor,  $D$ , for that particular apparatus and pressure. For this portion of the calibration, it will be satisfactory to use an approximate value for  $P$ . This is determined by making a preliminary test described in (f), except that an approximate value for calibration factor,  $K$ , will be used. For this test,  $K$ , will be approximate, because the factor,  $D$ , as yet unknown, is assumed to be zero. See (e).
- (e) Determination of calibration factor,  $K$ . The calibration factor,  $K$ , is the amount the water column must be depressed during the calibration procedure to obtain the gauge pressure required, so that graduations on the glass tube correspond directly to the percentage of air introduced into the measuring bowl by the calibration cylinder when the bowl is level full of water. Calculate  $K$  as follows:

$$K = 0.98R + D$$

(f) Calibration test to determine operating pressure,  $P$ , on pressure gauge. If the rim of the calibration cylinder contains no recesses or projections, fit it with three or more spacers equally spaced around the circumference. Invert cylinder and place it at the center of the dry bottom of the measuring bowl. The spacers provide opening for flow of water into the calibration cylinder when pressure is applied. Secure the inverted cylinder against displacement and carefully lower the conical cover into place and clamp. After cover is clamped in place, carefully adjust the apparatus assembly to a true vertical position. Add water at air temperature by means of the tube and funnel until water rises above the zero mark in the standpipe. Close vent and pump air into the apparatus to the approximate pressure. Incline the assembly about 30 degrees from vertical, and using bottom of the bowl as a pivot, describe several complete circles with the upper end of the standpipe. Simultaneously, tap over and sides of the bowl lightly to remove any entrapped air which might be adhering to inner surfaces of the apparatus. Return the apparatus to a vertical position, gradually release pressure to avoid loss of air (from the calibration cylinder), and open vent. Bring water level exactly to the zero mark by bleeding the petcock in the top of the conical cover. When the zero mark has been reached, close vent and apply pressure until the water level has dropped an amount equivalent to about 0.1 to 0.2 percent of air more than the value of the calibration factor,  $K$ , determined as described in (e). To relieve local restraints lightly tap sides of the bowl. When the water level is exactly at the value of calibration factor,  $K$ , read the pressure,  $P$ , indicated by the gauge and record to the nearest 0.1 psi. Gradually release pressure and open vent to determine whether the water level returns to the zero mark when sides of the bowl are tapped lightly. Failure to do so indicates loss of air from the calibration cylinder or loss of water due to a leak in the assembly. If the water level fails to return to within 0.05% air of the zero mark and no leakage beyond a few drops of water is found, some air probably was lost from the calibration cylinder. In this case, repeat the entire calibration procedure, step by step. If leakage is more than a few drops of water, tighten the leaking joint before repeating the calibration procedure. Check the indicated pressure reading promptly by bringing the water level exactly to the zero mark, closing vent, and applying the pressure,  $P$ , just determined. Tap gauge lightly with a finger. When gauge indicates the exact pressure,  $P$ , water column should read the value of the calibration factor  $K$ , used in the first pressure application. The reading should be within about 0.5 percent of air.

**Soiltest Meter** The easiest method of calibrating the Soiltest Air Meter is by using the calibration block.

**Special Note:** Use the 5% block only for checking in-between annual calibrations. The 5% block must be calibrated alongside the yearly calibration of the air-pot to note any offsets. dh - TCP – 11/13/2018

- a. Fill the material container with water
- b. Place the 5 percent calibration block in the material container.
- c. Place and clamp lid onto container, run air test as you normally would for concrete.
- d. If the gauge hand indicates 5 percent air ( $\pm$  any calibrated offset), the equipment is properly calibrated.
- e. If the gauge hand indicates air content other than 5 percent, adjust the initial starting point (the yellow needle) and run through the test again. This may be done a few times until the gauge is properly calibrated.

**Determination of Aggregate Correction Factor.** Determine the aggregate correction factor on a combined sample of fine and coarse aggregate by the methods outlined in the following paragraphs:

Calculate weights of fine and coarse aggregate present in the volume,  $S$ , of the sample of fresh concrete whose air content is to be determined as follows:

$$F_g = \frac{S \times F_b}{B}$$

$$C_g = \frac{S \times C_b}{B}$$

Where:

$F_s$  = weight of fine aggregate in concrete sample under test, in lbs.

$S$  = volume of concrete sample (Same as volume of measuring bowl of apparatus), in cubic feet.

$B$  = volume of concrete produced per batch, in cubic feet.

$F_b$  = total weight of fine aggregate in batch, in lbs.

$C_s$  = weight of coarse aggregate in concrete sample under test, in lbs., and

$C_b$  = total weight of coarse aggregate in batch, in lbs.

Mix representative samples of fine aggregate of weight,  $F_s$ , and coarse aggregate of weight,  $C$ , and place in the measuring bowl which has been previously filled 1/3 full of water. Add mixed aggregate a little at a time until all the aggregate is inundated. Add each scoopful in a manner that will entrap as little air as possible. Promptly remove accumulation of foam. Tap sided of the bowl and lightly rod the upper inch of the aggregate about 10 times. Stir after each addition of mixed aggregate to eliminate entrapped air.

While all the aggregate has been placed in the bowl and inundated for at least 5 minutes, strike off all foam and excess water, and thoroughly clean flanges of both the bowl and conical cover so that when the cover is clamped in place, a pressure tight seal will be obtained. Complete test as described below. The aggregate correction factor,  $G$ , is equal to  $h_1 - h_2$ , as determined in the tests on the aggregate. The factor will normally remain fairly constant for any given aggregates but since different aggregated will have different factors, a new factor must be determined for each source.



**501.1.8.2 Procedure for Determining Air Content of Concrete**

With the Protex Meter, place a representative sample of concrete in the measuring bowl in three equal layers. Consolidate each layer by rodding, and by tapping the bowl. When concrete is placed, consolidate each layer of concrete with 25 strokes of the tamping rod, evenly distributed over the cross section. Follow the rodding of each layer by tapping sides of the bowl with the mallet, until cavities left by rodding are leveled out and no large bubbles of air appear on the surface of the rodded layer. When rodding the first layer, rod should not strike bottom of the bowl. In rodding the second and final layers, use only enough force to cause the rod to penetrate the surface of the previous layer. Slightly overfill the bowl with the third layer. After rodding, remove excess concrete by sliding the strike off bar across the top flange with a sawing motion, until the bowl is just level full.

Thoroughly clean flanges of the bowl and conical cover so that when the cover is clamped in place, a pressure-tight seal will be obtained. Assemble the apparatus and add water over the concrete by means of the tube. Water should be added until it rises to about the half way mark in the standpipe. Incline the apparatus assembly about 30 degrees from vertical, using bottom of the bowl as a pivot. Describe several complete circles with the upper end of the column, simultaneously, tapping the conical cover lightly to remove any entrapped air bubbles above the concrete sample. Return the apparatus assembly to its vertical position. Fill the water column lightly above the zero mark, while lightly tapping sides of the bowl. Foam on the surface of the water column may be removed with a syringe or with spray of alcohol to provide a clear meniscus. Bring the water level to the zero mark of the graduated tube before closing vent at top of the water column.

Apply slightly more than the desired test pressure,  $P$  (about 0.2 psi more), to the concrete by means of the hand pump. To relieve local restraints, tap sides of the measure. When the pressure gauge indicates exact test pressure,  $P$  (as determined in accordance with instructions for the calibration test), read the water level,  $h_1$ , and record to the nearest division or half division (0.10 or 0.05% air content) on the graduated bore tube or gauge glass of the standpipe. For extremely harsh mixes, it may be necessary to tap the bowl vigorously until further tapping produces no change in indicated air content. Gradually release air pressure to vent at the top of the water column, and tap sides of the bowl lightly for about 1 minute. Record the water level,  $h_2$ , to the nearest division or half division. The apparent air content,  $A_1$  is equal to  $h_1 - h_2$ .

Repeat the steps described in Section 501.16.4.3.3.2 without adding water to reestablish the water level at the zero mark. The two consecutive determinations of apparent air content should check within 0.2% of the air. Use the average to get the value.  $A_1$ , to be used in calculating the air content,  $A$ , in accordance with Section 501.16.4.4.

**Calculation.** Calculate the air content of the concrete as follows:

$$A = A_1 - G$$

Where:

$A$  = Air content percentage, by volume of concrete.

$A_1$  = Apparent air content percentage, by volume of concrete.

$G$  = Aggregate correction factor percentage, by volume.



Concrete placement shall be halted if results of tests for entrained air indicate non-compliance with specification requirements.

Data for tests for air entrainment should be entered directly in a bound field book by the inspector. The aggregate correction factor should be determined at start of the work for each mix and complete data and calculation entered in the field book. Each test for determination of operating pressure, P, must also be entered.

In the record of test for air entrainment the aggregate correction factor and operating pressure should be identified with the test from which they were determined. This can be done by reference to book and page on which the test is recorded.



**AASHTO T152**  
**Air content of freshly Mixed Concrete by Pressure Method**

**PROFICIENCY CHECKLIST**

Applicant: \_\_\_\_\_

Employer: \_\_\_\_\_

	Trial#	1	2
<b>General</b>			
1. Bowl dampened			
2. Bowl filled in three equal layers			
3. Each layer rodded 25 times			
4. After rodding each layer, bowl tapped 10 to 15 times with a mallet			
5. Excess concrete removed with sawing motion of strike-off bar			
<b>Type "B" Meter</b>			
1. flanges of bowl cleaned and unit assembled			
2. Air valve between air chamber and bowl closed			
3. Using rubber syringe water injected through one petcock until water emerged from opposite petcock			
4. Meter jarred gently until all air was expelled			
5. Air pumped into chamber until gauge hand is on initial pressure line			
6. Waited a few seconds to allow for the gauge to stabilize at the initial pressure line.			
7. Initial pressure stabilized while tapping gauge lightly			
8. Petcocks closed. (Not before filling of air chamber, Step 5)			
9. Air valve between air chamber and measuring bowl opened			
10. Sides of measuring bowl tapped sharply			
11. Pressure gauge tapped lightly and percentage of air read			
12. Air content of sample calculated as follows: Air content (%) = Apparent Air Content – Aggregate Correction Factor			
13. Aggregate correction factor determined for different aggregates			

PASS    PASS

FAIL    FAIL

Examiner: \_\_\_\_\_ Date: \_\_\_\_\_



# **AASHTO R100**

## **Making and Curing Of Concrete Beam Specimens in the Field**

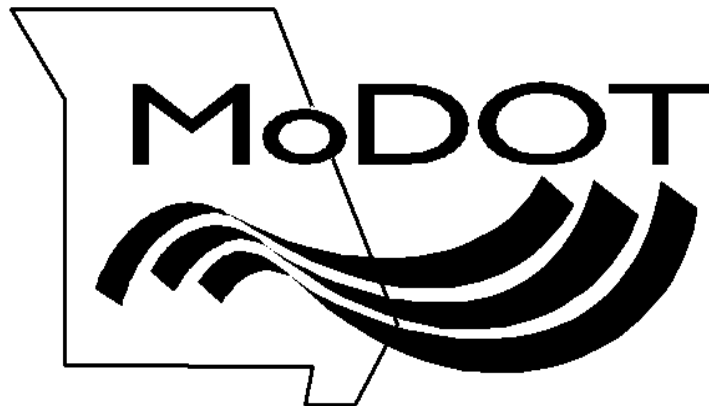



# AASHTO R100

## Making and Curing Concrete Test Specimens in the field



Cylinders



Beams

Revised 10/23/2024

1

---

---

---

---

---

---

---

---

### SCOPE

- This practice covers procedures for making and curing cylinder and beam specimens from representative samples of fresh concrete for a construction project.
- The concrete used to make the molded specimens shall be sampled after all on-site adjustments have been made to the mixture proportions, including the addition of mix water and admixtures.

2

2

---

---

---

---

---

---

---

---

### SIGNIFICANCE AND USE

- This practice provides standardized requirements for making, curing, protecting, and transporting concrete test specimens under field conditions.
- For acceptance testing for strength, perform the following 3 tests for each sample of concrete from which the specimens are made.
  1. Slump
  2. Air Content
  3. And Temperature

3

3

---

---

---

---

---

---

---

---

### **EQUIPMENT**

- Tamping Rod  
(Size determined by the size of specimen being made)
  - Cylinder Mold and Cap
  - Beam Molds  
(See the Appendix for specifics)
  - Scoop
  - Marker
  - Trowel or Straight-Edge
  - Internal Vibrator
  - Mallet  
(Rubber or rawhide weighing 0.75-1.75 lb.)
  - Personal Protective Equipment  
(Safety Vest, Gloves, Hard Hat etc.)
- See **Appendix** for additional equipment information.

---

---

---

---

---

---

---

---

4

### **TESTING REQUIREMENTS**

- The number and size of specimens for acceptance testing is determined by the agency in charge.
- If NMAS > 2 inches, wet sieve over a 2" (50mm) sieve using AASHTO R60.
- Method of consolidation is based on the slump table 3:

AASHTO Table 3	
Slump	Consolidation Method
≥ 1 inch	Rod or Vibrate
≤ 1 inch	Vibrate

5

---

---

---

---

---

---

---

---

5

### **MOLDING SPECIMEN LOCATION**



- Promptly mold Cylinders and Beams as close as possible to the place where they are to be stored.
- Mold specimens on a level rigid surface.
- Surface should be free of vibration and other disturbances.

6

---

---

---

---

---

---

---

---

6



### Summary for Casting Cylinders and Beams

- Sample concrete per AASHTO R60.
- Test Temperature, Slump, and Air.
- Determine method of consolidation from slump result (see Table 3).
- Select proper size mold, scoop, tamping rod or vibrator.
- Consolidate each layer according to size of the sample.
- Vibrate or rod into previous layers by 1 inch
- Final layer, add enough concrete to over-fill the mold after consolidation.
- Finish by striking off the excess concrete using a tamping rod, float, or trowel.
- Prepare specimens for initial curing.

7

---

---

---

---

---

---

---

---

7

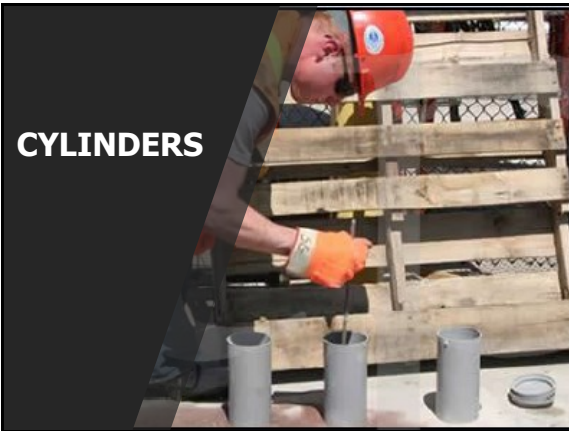

8

---

---

---

---

---

---

---

---

### TESTING REQUIREMENTS - Cylinders

NMAS = Nominal Maximum Aggregate Size

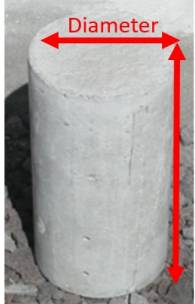

- **Diameter**  
≥ 3 x NMAS
- **Length**  
2 x Diameter
- **Acceptance Testing**  
6" x 12" cylinder  
or  
4" x 8" cylinder

Fig.1: Concrete Cylinder for Compression Test

9

9

---

---

---

---

---

---

---

---

### 6 x 12" Cylinders

<ul style="list-style-type: none"> <li>• <b>Rodding</b> 5/8" Rod 3 Lifts 25 Rods per Lift (Penetrate previous lift by 1")  – <b>Tap 10-15 times with a mallet after each lift is consolidated.</b> Use open hand on single use molds that could be damaged from using a mallet.</li> </ul>	<ul style="list-style-type: none"> <li>• <b>Vibration</b> Internal Vibrator 2 lifts 2 insertion per lift (Penetrate previous lift by 1")  – <b>Tap 10-15 times with a mallet after each lift is consolidated.</b> Use open hand on single use molds that could be damaged from using a mallet.</li> </ul>
--	---

10

10

---

---

---

---

---

---

---

---

### 4 x 8" Cylinders

<ul style="list-style-type: none"> <li>• <b>Rodding</b> 3/8" Rod 2 Lifts 25 Rods per Lift (Penetrate previous lift by 1")  – <b>Tap 10-15 times with a mallet after each lift is consolidated.</b> Use open hand on single use molds that could be damaged from using a mallet.</li> </ul>	<ul style="list-style-type: none"> <li>• <b>Vibration</b> Internal Vibrator 2 lifts 1 insertion per lift (Penetrate previous lift by 1")  – <b>Tap 10-15 times with a mallet after each lift is consolidated.</b> Use open hand on single use molds that could be damaged from using a mallet.</li> </ul>
--	---

11

11

---

---

---

---

---

---

---

---



**PROCEDURE**  
**RODDING**  
**6" x 12" Cylinders**

12

---

---

---

---

---

---

---

---

**1<sup>ST</sup> LAYER**  
6"X 12" Cylinders

Filling 1<sup>st</sup> Layer  
1/3 of Volume,  
Move scoop  
around the  
perimeter.

Rodding 25 times  
do not forcibly  
strike the bottom.

Tapping 10-15 times  
with a mallet or Use  
palm of hand for single  
use molds susceptible  
to damage.

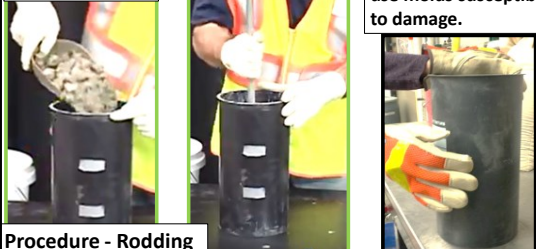

Procedure - Rodding 13

13

---

---

---

---

---

---

---

---

---

---

**2<sup>ND</sup> LAYER**  
6"X 12" Cylinders

Filling 2<sup>nd</sup> Layer  
2/3<sup>rd</sup>s of volume.

Measuring 1 inch  
Into first layer.

Rodding 25 times.

Tapping 10-15

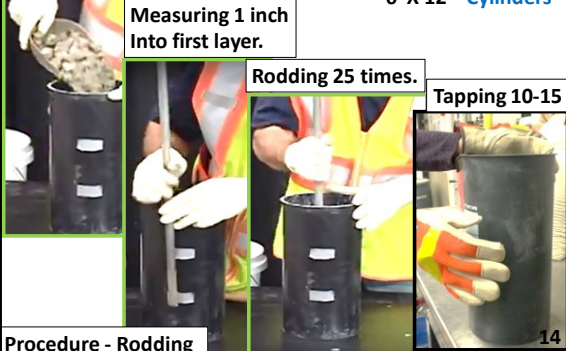

Procedure - Rodding 14

14

---

---

---

---

---

---

---

---

---

---

**3<sup>RD</sup> LAYER**  
6"X 12" Cylinders

Slightly over fill  
Final 3<sup>rd</sup> Layer

Measuring 1 inch  
Into 2<sup>nd</sup> layer.

Rodding 25 times

Tapping 10-15

- Under filled molds - add concrete during consolidation.
- After tapping the last layer go to the [Finishing Procedure for Cylinders.](#)

Procedure - Rodding 15

15

---

---

---

---

---

---

---

---

---

---



**PROCEDURE**  
**Vibrating**  
**6" x 12" Cylinders**

16

---

---

---

---

---

---

---

---

**Vibrating 6 x 12" Cylinder:**

- Complete 2 equal lifts/layers.
- Move the scoop around the perimeter when filling.
- Vibrate after each layer.
- Avoid touching the sides or bottom of the mold.
- Tap the sides with a mallet 10-15 times.
  - For light gauge molds **susceptible to damage** use an open hand to tap the sides.
- On the last layer, do not overfill by more than 1/4".
- Number of Insertions per lift:
  - **1 location** for 4" x 8" cylinders.
  - **2 locations** for 6" x 12" cylinders

17

17

---

---

---

---

---

---

---

---

- Vibrate into the *lower* layer approximately **1"**
- Slowly remove the vibrator to avoid air pockets.
- Continue vibration only long enough to achieve proper consolidation.
  - Up to 5 seconds for slumps > 3"
  - Up to 10 seconds for slumps ≤ 3"
  - Exceeding 10 seconds is rare.
- After tapping the last layer go to the **Finishing Procedure for Cylinders.**

18

18

---

---

---

---

---

---

---

---

**PROCEDURE  
FINISHING  
6 x 12"  
Cylinders**



19

---

---

---

---

---

---

---

---

**FINISHING PROCEDURE - Cylinders**



- Strike-off excess concrete using a tamping rod, float or trowel.

–Use the minimum manipulation necessary to produce a flat, even surface level with the rim of the mold.

–No depressions or projections greater than  $\frac{1}{8}$ "

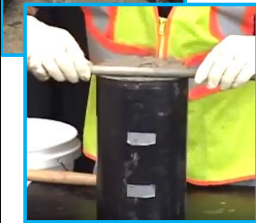

20

20

---

---

---

---

---

---

---

---

**IDENTIFICATION - Cylinders**

- Wipe off excess concrete.
- Put the cap on.
- Write the ID and other information on the mold, not the cap.
- Secure the lid with duct tape.

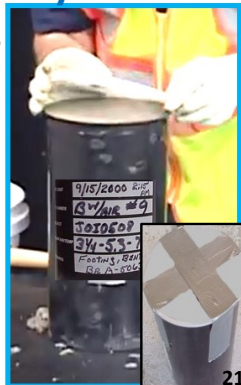

21

21

---

---

---

---

---

---

---

---

- Within 15 minutes of molding, move to cylinders to initial place of curing.
- Maintain cylinders in upright position.
- Protect specimen from moisture loss, direct sunlight, and radiant heating devices.
- Initial Curing begins
  - Store for a period of 48 hours at 60 to 80° F
  - Specimens that are  $\geq 6,000$  PSI store at 68 to 78° F
  - Record temperature with a min/max thermometer.



22

22

---

---

---

---

---

---

---

---

### **TRANSPORTATION**

- Transport Specimens
  - Specimens shall not be transported until at least 8 hours after final set.
  - **MoDOT** Cylinders; after the initial cure period, the specimen shall be removed from the mold and placed in a sealed plastic bag to maintain free moisture during shipping.
- Protect specimens during transport from:
  - Jarring
  - Freezing
  - Moisture loss
- Transportation
  - Time allowed  $\leq 4$  hours

23

23

---

---

---

---

---

---

---

---

### **BEAMS**

Note: All tables are at the end of this presentation.



24

24

---

---

---

---

---

---

---

---

## TESTING REQUIREMENTS - Beams

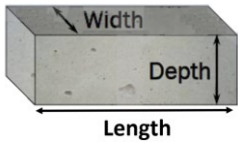

**Standard Beam**  
**6" x 6" x 20"**

- **Beams**
  - **Ratio of Width to Depth**
    - $\frac{\text{Width}}{\text{Depth}} \leq 1.5$
  - **Length**
    - $2" > 3 \times \text{depth}$
  - Standard beam shall be 6 x 6 unless otherwise specified.

25

25

---

---

---

---

---

---

---

---

## PROCEDURE – Molded Beams

### 6" X 6" X 20" Beam

- Fill the beam in the correct number of lifts
  - Rodding – 2 lifts
  - Vibration – 1 lift
- When filling the final layer, avoid overfilling by more than  $\frac{1}{4}"$ .

26

26

---

---

---

---

---

---

---

---



**PROCEDURE**  
**Rodding**  
**6" x 6" x 20" Beams**

27

---

---

---

---

---

---

---

---



**PROCEDURE – Rodding Beams**

**6" x 6" x 20" Beam**

- Use a 5/8" Rod
- Each layer , 1 rod every 2 in.<sup>2</sup> of surface area.
  - 60 rods/lift.
  - Penetrate previous lifts about 1".
- Tap mold 10 – 15 times with a mallet after each lift has been consolidated.
- When placing the final layer, avoid overfilling by more than 1/4 ".
- Spade each layer with a trowel.
  - Spade sides and ends.

28

28

---

---

---

---

---

---

---

---



29

29

---

---

---

---

---

---

---

---



30

30

---

---

---

---

---

---

---

---



**PROCEDURE – Vibrating Beams**

- Insert vibrator full depth.
  - Don't touch mold with vibrator.
  - Vibrate about 10 sec. per insertion or less.
- Insert at Intervals  $\leq 6''$  along centerline.
  - 3 - 4 insertions for a standard beam (6"x 6"x 20")



31

31

---

---

---

---

---

---

---

---

**PROCEDURE – Vibrating Beams**

- For beams wider than 6" use alternating insertions along two lines.

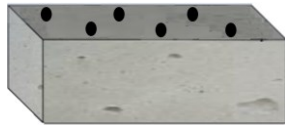

- Tap mold sharply 10 – 15 times with a mallet after each lift has been consolidated.
- Do not spade.

32

32

---

---

---

---

---

---

---

---

**Finishing – Beams**

- Finish beams using a float or trowel.
  - Use minimum manipulation necessary.
    - Strike off the top surface.
    - Work for a flat even surface that is level with the rim or edge of the mold.
  - No depressions or projections greater than  $\frac{1}{8}''$ .
  - Within 15 minutes of molding, move to initial place of curing.

33

33

---

---

---

---

---

---

---

---

## Finishing – Beams

- Refinish surface if needed.
- Place ID tag on outside of mold.
- Protect from moisture loss.
  - Use plastic sheeting.

34

34

---

---

---

---

---

---

---

---

## Consolidation Quick Chart for Beams

Rodding	Vibration
$\frac{3}{8}$ " Rod (4 inch in width) $\frac{5}{8}$ " Rod (6-8 inch in width)	Do not touch mold with Vibrator
<b>2 Lifts</b>	<b>1 Lift</b> (avoid over filling > $\frac{1}{4}$ " )
Rod once every 2-inch <sup>2</sup> of surface area. Penetrate previous layer by 1 inch.	<b>1</b> insertion per lift Insert full depth at intervals $\leq 6"$ along center line. 4 insertions standard beam Beams wider than 6", use alternating insertions along 2 lines
<b>Tap 10-15 times</b> with a mallet per lift	<b>Tap 10-15 times</b> with a mallet per lift
Spade each layer with trowel Sides and ends	Do not spade

35

35

---

---

---

---

---

---

---

---

## CURING

- **Curing** is the process of maintaining moisture and temperature conditions for proper hydration of concrete mixtures.



36

---

---

---

---

---

---

---

---

<ul style="list-style-type: none"> <li>• <b>Standard Curing</b> <ul style="list-style-type: none"> <li>– Acceptance testing for specified strength</li> <li>– Checking adequacy of mixture proportions</li> <li>– Quality control</li> </ul> </li> </ul>	<ul style="list-style-type: none"> <li>• <b>Field Curing</b> <ul style="list-style-type: none"> <li>– Determining when a structure may be put into service</li> <li>– Form removal time</li> <li>– Checking adequacy of curing and protection of structure</li> <li>– Comparison tests</li> </ul> </li> </ul>
Significance and Use	37

---

---

---

---

---

---

---

---

37

<p align="center"><b>Standard Curing - Cylinders</b></p> <ul style="list-style-type: none"> <li>• Includes two parts:           <ol style="list-style-type: none"> <li>1. <b>Initial Curing:</b> Is the time in which the fresh concrete "sets" and becomes rigid.</li> <li>2. <b>Final Curing:</b> Is the time in which the fresh concrete begins to harden and gain strength.</li> </ol> </li> </ul>
38

---

---

---

---

---

---

---

---

38

<p align="center"><b>Standard Curing - Cylinders</b></p> <ul style="list-style-type: none"> <li>• Initial Curing Conditions:           <ul style="list-style-type: none"> <li>– Time Period               <ul style="list-style-type: none"> <li>• Up to 48 hours after molding.</li> </ul> </li> <li>– Temperature               <ul style="list-style-type: none"> <li>Record temp. using a <b>Max-Min Thermometer</b> <ul style="list-style-type: none"> <li>• For specimens &lt; 6000 psi 60 to 80 °F</li> <li>• For specimens ≥ 6000 psi 68 to 78 °F</li> </ul> </li> </ul> </li> </ul> </li> </ul>	
39	

---

---

---

---

---

---

---

---

39

### Standard Curing - Cylinders

- Choose one or more of the following to control moisture environment of the specimen:

Cover with containers with removable plastic lids.

- Store in properly constructed boxes.
- Damp sand pits.
- Place inside plastic bags.
- Immediately immerse in water saturated with calcium hydroxide.



40

40

---

---

---

---

---

---

---

---

### Standard Curing - Cylinders

- Controlling Temperature

– Thermostatically controlled heating and cooling devices.

- Light bulbs
- Fans
- Water baths
- Ice

– Record minimum and maximum temperatures for each set.

– Shield specimens from direct sunlight, heat or loss of moisture.



41

41

---

---

---

---

---

---

---

---

### Standard Curing - Cylinders

- Remove Molds

- Copy identification markings on to specimen.
- Final curing must begin within 30 minutes of mold removal.

- Final Curing

- Always maintain free water on surfaces using;
  - Moist rooms
  - Storage tanks

- Temperature

- $73.5 \pm 3.5$  °F

- At the end of curing, test the specimen.

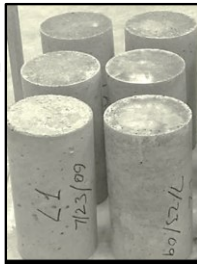

42

---

---

---

---

---

---

---

---

### Standard Curing – Beams

- **Beams** are cured same as cylinders, except beams are stored in water saturated with calcium hydroxide at 70 to 77°F for at least 20 hours prior to testing.
- Guard against drying between time of removal from curing to testing.



43

---

---

---

---

---

---

---

---

43

### Field Curing - Cylinders

- **Field Curing Conditions**
  - Store near the point of deposit.
  - Protect like the formed concrete.
    - Provide like temperature and moisture conditions.
      - Including during transport.
  - Remove cylinders from molds when formwork is removed.
- **Testing**
  - Remove from field
    - Maintain moisture and test in "as is" condition.

44

---

---

---

---

---

---

---

---

44

### Field Curing - Beams

- Cure in the same manner as concrete in the structure.

At the end of  $48 \pm 4$  hours, take the molded beams to the storage location and remove the molds.
- **Slabs**
  - Store on ground as molded, with top surfaces up.
  - Bank sides and ends with damp earth or sand leaving top surface exposed.

45

---

---

---

---

---

---

---

---

45

## Field Curing - Beams

- Structures
  - Store beams near the structure they represent.
  - Provide same temperature protection and moisture environment as structure.
- Testing
  - Remove from field and store in water saturated with calcium hydroxide for  $24 \pm 4$  hours prior to testing.

46

46

---

---

---

---

---

---

---

---

## REPORT

- Identification number
- Location of concrete represented by the samples
- Date, Time, and Name of individual molding specimens
- Test Results
  - Slump, air content, and temperature
  - Method Deviations
- Curing Method –
  - **For Standard Curing:** Report the initial with Max and Min Temperatures and final curing method.
  - **For Field Curing:** Report the location where stored, manner of protection from the elements, temperature, and moisture environment, and time of removal from molds.

47

47

---

---

---

---

---

---

---

---

## Common Errors:

- Not enough or too many strokes of rod per layer.
- Uneven distribution of strokes around layer.
- Mold not lightly tapped after rodding each layer.
- Shipped without maintaining proper moisture.



48

48

---

---

---

---

---

---

---

---

## TABLES

49

49

---

---

---

---

---

---

---

---

### **CASTING - Cylinders**

- Select tamping rod or vibrator from Table 1.
- Determine method of consolidation Table 3.
- Rodding, molding requirements on Table 4.
- Vibrating, molding requirements on Table 5.
- Select the right size scoop.
- While placing the sample in the mold, move the scoop around the perimeter of the mold.
- Consolidate each layer as required.
- *Self-Consolidating Concrete* – cast specimens without layers or consolidation.

50

50

---

---

---

---

---

---

---

---

### **AASHTO Table 1**

#### Tamping Rod Requirements

Diameter of cylinder or Width of Beam mm (inch)	Rod Dimensions <sup>a</sup>	
	Diameter mm (inch)	Length of rod mm (inch)
<b>&lt; 150 (4)</b>	<b>10 (3/8)</b>	<b>300 (12)</b>
<b>150 (6)</b>	<b>16 (5/8)</b>	<b>500 (20)</b>
<b>225 (9)</b>	<b>16 (5/8)</b>	<b>600 (24)</b>

<sup>a</sup>Rod tolerances length ± 100mm (4 inches) and diameter ±2mm (1/16 inch).

51

51

---

---

---

---

---

---

---

---

<b>AASHTO Table 3 - Cylinders</b>	
<b>Method of Consolidation Requirements</b>	
<b>Slump, mm (in)</b>	<b>Method of Consolidation</b>
<b>≥25mm (≥ 1 inch)</b>	<b>Rodding or Vibration</b>
<b>≤25mm (≤1 inch)</b>	<b>Vibration</b>
<b>NOTE: 1" you can Rod or Vibrate</b>	

52

52

---

---

---

---

---

---

---

---

<b>AASHTO Table 4 - Cylinders</b>		
<b>Molding Requirements by Rodding</b>		
<b>Specimen Type and Size Cylinders:</b>	<b>Number of Layers of Approximately Equal Depth</b>	<b>Number of Roddings per Layer</b>
<b>Diameter, mm (inch)</b>		
<b>100 (4 inch)</b>	<b>2</b>	<b>25</b>
<b>150 (6 inch)</b>	<b>3</b>	<b>25</b>
<b>225 (9 inch)</b>	<b>4</b>	<b>50</b>

53

53

---

---

---

---

---

---

---

---

<b>AASHTO Table 1 - Beams</b>		
<b>Tamping Rod Requirements</b>		
	<b>Rod Dimensions<sup>a</sup></b>	
<b>Diameter of cylinder or Width of Beam mm (inch)</b>	<b>Diameter mm (inch)</b>	<b>Length of rod mm (inch)</b>
<b>&lt; 150 (6)</b>	<b>10 (3/8)</b>	<b>300 (12)</b>
<b>150 (6)</b>	<b>16 (5/8)</b>	<b>500 (20)</b>
<b>225 (9)</b>	<b>16 (5/8)</b>	<b>600 (24)</b>

<sup>a</sup>Rod tolerances length ± 100mm (4 inches) and diameter ±2mm (1/16 inch).

54

54

---

---

---

---

---

---

---

---



<b>AASHTO Table 2 - Beams</b>	
<b>Minimum cross-Sectional Dimensions of Beams</b>	
<b>Nominal Maximum Aggregate Size (NMAS)</b>	<b>Minimum Cross-Sectional Dimension</b>
≤ 25mm (≤ 1 inch)	100 by 100mm (4 x 4 inches)
25mm (1 inch) < NMAS ≤ 50mm (2inch)	152 by 152 mm (6 by 6 inches)

55

55

---

---

---

---

---

---

---

---

<b>AASHTO Table 3 - Beams</b>	
<b>Method of Consolidation Requirements</b>	
<b>Slump, mm (in)</b>	<b>Method of Consolidation</b>
≥25mm (≥ 1 inch)	Rodding or Vibration
≤25mm (≤1 inch)	Vibration

56

56

---

---

---

---

---

---

---

---

<b>AASHTO Table 4 - Beams</b>		
<b>Molding Requirements by Rodding</b>		
<b>Specimen Type and Size Beams:</b>	<b>Layers of Approx. Equal Depth</b>	<b>Roddings per Layer</b>
<b>Width, mm (inch)</b>	2	Once every 2 inch <sup>2</sup> of surface area
100 (4 inch) to 200 (8 inch)		
Over 200 (8 inch)	3 or more equal depths, each not to exceed (6 inch)	Once every 2 inch <sup>2</sup> of surface area

57

---

---

---

---

---

---

---

---

<b>AASHTO Table 5 - Beams</b>			
<b>Molding Requirements by Vibration</b>			
<b>Beam Width</b>	<b>Layers</b>	<b>Vibrator Insertions per Layer</b>	<b>Approximate Depth of Layer</b>
<b>6 to 8 inches</b>	<b>1</b>	<b>*</b>	Depth of specimen as near as practicable
<b>&gt; 8 inches</b>	<b>2 or more</b>	<b>*</b>	Depth of specimen as near as practicable

\*Vibrator inserted at intervals not exceeding 6 inches, use alternating insertions along two lines.

58

---



---



---



---



---



---



---



---

58

## AASHTO Table 5

<b>Table 5 – Molding Requirements by Vibration</b>			
Specimen Type and Size	Number of Layers	Number of Vibrator Insertions per Layer	Approximate Depth of Layer
<b>Cylinder Diameter**</b>			
4 in.	2	1	1/2 depth of specimen
6 in.	2	2	1/2 depth of specimen
9 in.	2	4	1/2 depth of specimen
<b>Beam Width</b>			
6 to 8 in.	1	*	depth of specimen as near as practicable
>8 in.	2 or more	*	depth of specimen as near as practicable

\* Vibrator inserted at intervals not exceeding 6 in. along center of line of long dimension of specimen. For specimens wider than 6 in., use alternating insertions along two lines.

\*\* Cylinders at least three times the nominal maximum size of the coarse aggregate

#### **501.1.3.4 Protection of sample**

After the sample has been obtained, it must be protected from direct sunlight and wind until it is used, which must not be more than 15 minutes after sampling. When the sample has been moved to the place where the test is to be made or specimens are to be molded it should be mixed with a shovel if necessary to assure uniformity of the mixed sample.

#### **501.1.3.5 Compressive Strength**

Compressive tests are performed both in the field and in the laboratory on cylindrical specimens of concrete, 6 in. diameter and 12 in. tall (6x12) or 4 in. diameter and 8 in. tall (4x8). The Standard Specifications require use of compressive specimens for job control of concrete production.

All concrete for air and slump tests as well as preparation of the specimens should be secured from a single batch of concrete. Air and slump tests should always be made on samples of concrete used for preparation of compressive specimens.

Cylinder forms shall be filled with fresh concrete in accordance with the instructions provided by AASHTO R 100 (ASTM C 31). Care should be taken when placing the caps on the molds to avoid damage to the surface of the concrete. The lids should be kept on tight to prevent moisture loss.

##### **501.1.3.5.1 Curing**

Curing of compressive specimens will depend on whether they are for standard cure or field cure.

Standard Cure is defined as 1) specified strength for 28-day testing; 2) Check of mixture proportions or design strength; 3) Quality control (i.e. monitoring mix variability) or 4) Maturity meter curve.

Standard curing involves two phases of curing: initial and final.

Each set of compressive test specimens for standard cure consists of two 6x12 cylinders or three 4x8 cylinders. Standard Cure specimens shall be cured in accordance with AASHTO R 100 (ASTM C31) for initial and final curing.

##### **Standard Cure – Initial**

If specimens cannot be molded at the place where they will receive initial curing, immediately after finishing move the specimens to an initial curing place for storage. Recommended method for initial curing is keeping the specimen in the plastic mold covered with a plastic lid or place in a damp sand pit for a maximum of 48 hours in a temperature range from 60° F to 80° F and an environment preventing moisture loss.

##### **Standard Cure - Final**

Upon completion of initial curing and within 30 minutes of removing the molds, cure specimens with free water maintained on their surfaces at all times at a temperature of 70° F to 77° F using water storage tanks or moisture room per AASHTO M201 (ASTM C511).

**Storage Tanks** When water tanks are used for final curing the temperature shall be maintained at 70° F to 77° F. Method of recording temperature is required. Transportation of Specimens may be transported to the Central Laboratory for final curing. To transport, after the initial cure period, the specimen shall be removed from the mold and placed in a plastic bag to maintain free moisture during shipping. Specimens should not be transported to begin final cure until at least 8 hours after final set. During transporting, use suitable material to prevent damage from jarring and use suitable insulation material during cold weather. Show shipper's name and address on the outside of the box. The box comes with the address of Central Laboratory printed on the side and a preprinted form that provides basic information about the cylinders. If the box does not have the form preprinted, contact the Central Laboratory for copies of the self-stick form. Sample ID number should be written on the side of cylinders or cylinder molds. Necessary boxes, cardboard liners, polyethylene bags, wire ties and rolls of strapping tape are stock items available by requisition.

#### Field Curing

Field cure is defined as 1) Opening to traffic strength or staged construction; 2) Comparison with test results of standard cure to in place methods, such as maturity method verification; 3) Adequacy of curing and protection of concrete in the structure, such as cold weather placement or 4) Form removal.

Field curing shall be in accordance with AASHTO R100 (ASTM C 31). Store cylinders in or on the structure as near as practical to the represented concrete. Protect all surfaces of the cylinders from the elements, and ensure a temperature and moisture environment similar to the formed work. To meet these conditions specimens made for the purpose of determining when a structure is capable of being put in service shall be removed from the molds at the time of removal of form work.

Compressive test specimens for field cures may consist of one or more for either 6x12 cylinders 4x8 cylinders. Specimens prepared to determine when forms may be removed will be cured as described in above except for bridge decks or heated concrete. Specimens representing bridge decks are to be cured on the deck under wet mats until the cylinders are to be broken or wet curing is discontinued. If cylinders remain after wet curing has ended, they shall be cured in plastic molds under field conditions until they are to be broken.

Specimens representing heated concrete are to be left in the enclosure subject to the same protection as concrete they represent until they are to be broken. Cylinders should be left in molds and covered with wet burlap for 48 hours. If cylinders remain after the heating period has ended they shall be cured in plastic molds under field conditions until they are to be broken.

Curing of bridge decks shall be in accordance with Standard Specification 704, wet curing shall be maintained for 7 days and until the concrete has reached a minimum of 3000 psi.



**AASHTO R100 Making and Curing  
of  
Concrete Cylinder Specimens  
in the Field  
PROFICIENCY CHECKLIST**

Applicant: \_\_\_\_\_

Employer: \_\_\_\_\_

	Trial#	1	2
Sampled concrete per AASHTO R60			
Conducted Slump, Air Content, and Temperature Tests a. Reported results.			
<b>Molding Cylinders</b>			
1. Each layer properly consolidated per results of Slump, AASHTO T119			
2. 4" x 8" Mold filled in 2 approx. equal layers (Vibrated = 2 layers)			
6" x 12" Mold filled in 3 approx. equal layers (Vibrated = 2 layers)			
3. Rod each layer 25 times a. 4" x 8", vibrator, one location per layer b. 6" x 12", vibrator, two locations per layer			
4. Mold tapped lightly 10 to 15 times after each layer			
5. Mold tapped with mallet or open hand for light gauge single use molds			
6. Cylinder finished using either a tamping rod, handheld float, or a trowel so that the specimen is level with the rim of the mold.			
7. Mold properly cleaned and sealed with cap			
8. Identification information written on the container side and duct tape closed			
9. Set up initial cure per AASHTO R100 at 60-80°F			
10. Reported all core information, temperatures, and curing information			

PASS PASS  
FAIL FAIL

Examiner: \_\_\_\_\_ Date: \_\_\_\_\_





**AASHTO R 100 Making and Curing  
of  
Concrete BEAM Specimens  
In the Field  
PROFICIENCY CHECKLIST**

Applicant: \_\_\_\_\_

Employer: \_\_\_\_\_

	Trial#	1	2
Sample concrete per AASHTO R60			
Conducted Slump, Air Content, and Temperature Procedures a. Reported all results of these tests			
<b>Molding Beams – 6" x 6" Standard Size</b>			
1. Each layer properly consolidated per results of slump, AASHTO T 119			
2. Mold filled in 2 approximately equal layers (Vibrated = 1 layer)			
3. Rodded each layer every 2 square inches of surface area, into 1 inch of the layer below it. Spade each layer on the ends and sides. a. If vibrator used, 1 insertion per layer, insert full depth at intervals of approximately 6 inches along the center line of the length of the mold alternating insertions between 2 lines. Do not spade when consolidating by vibration.			
4. Mold tapped lightly 10 to 15 times after each layer was rodded			
5. Beam finished using either a tamping rod, handheld float, or a trowel so that the specimen was level with the rim of the mold			
6. Identification, information written on the mold			
7. Beams cured the same as cylinders, except they are stored in water saturated with calcium hydroxide at 70-77°F at least 20 hours prior to testing			
8. Reported all beam information, temperatures, and curing information			
<b>Transportation</b>			
1. Waited at least 8 hours after final set to transport, protected specimens from the cold, moisture maintained, and did not exceed 4 hours of transport time			

PASS    PASS

FAIL    FAIL

Examiner: \_\_\_\_\_ Date: \_\_\_\_\_



# **AASHTO T 121M**

ASTM C138

**Density (Unit Weight), Yield,  
and Air Content (Gravimetric)  
of Concrete Method**

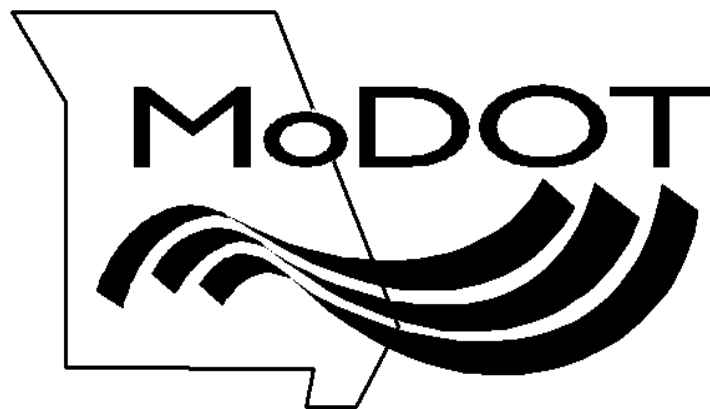



# AASHTO T121M

## Density (Unit Weight), Yield, and Air Content (Gravimetric) of Concrete



Updated  
Rev 10/23/2024

1

---

---

---

---

---

---

---

---

### SCOPE

- This method covers determination of the density of freshly mixed concrete and gives formulas for calculating:
  - Yield
  - Relative Yield
  - Cement Content
  - Gravimetric Air Content

2

2

---

---

---

---

---

---

---

---

### TERMINOLOGY - DEFINITIONS

**Absolute Volume (V)** – The absolute volume of each ingredient in cubic yards is equal to the quotient of the mass of the ingredient divided by the product of its specific gravity times 62.4.

**Total Mass (M)** – The total mass of all materials batched is the sum of the masses of the cement, the fine aggregate in the condition used, the coarse aggregate in the condition used, the mixing water added to the batch, and any other solid or liquid materials used.

**Yield** is defined as the volume of concrete produced from a mixture of known quantities of the component materials.

3

3

---

---

---

---

---

---

---

---

## EQUIPMENT

### Scale

- Accurate to 0.1 lb. (45g) or 0.3% of test load  
Whichever is greater.



### Measure

- Steel or suitable metal.
- Capacity of measure is based on NMAS (see table 1).
  - May use pressure meter bowl (if NMAS if meets table 1).
- Top rim of air meter bowls must be smooth and plane within 0.01" (0.3mm).

4

4

---

---

---

---

---

---

---

---

**Table 1: Required Measure Capacity**

Nominal Maximum Size of coarse Aggregate		Capacity of Measure	
mm	Inch	Liter	ft <sup>3</sup>
25.0	<b>1</b>	6	<b>0.2</b>
37.5	<b>1.5</b>	11	<b>0.4</b>
50	<b>2</b>	14	<b>0.5</b>
75	<b>3</b>	28	<b>1.0</b>
112	<b>4.5</b>	70	<b>2.5</b>
150	<b>6</b>	100	<b>3.5</b>

5

5

---

---

---

---

---

---

---

---

## EQUIPMENT

### Tamping Rod

- 5/8 ± 1/16" steel
- Hemispherical tip
- At least 4" > than the measure depth, but ≤ 24 ± 1/8" length.



### Internal Vibrator

- Element 3/4 - 1 1/2" diameter
- Frequency ≥ 9000 vibrations per min. while in concrete.
  - Verify at least every 2 years.
- Outside diameter of the vibrating element between 0.75 - 1.50".
- Length of the vibrator shaft and element shall be at least 3" above the depth being vibrated.

6

6

---

---

---

---

---

---

---

---

## **EQUIPMENT**

- **Scale**
  - Accurate to 0.1 lb. (45g) or
  - 0.3% of test load which ever is greater accuracy.
- **Strike-Off Plate –**
  - **Size**
    - Length and width at least 2" greater than the diameter of the measure.
  - **Can be Metal, Glass or Acrylic**
    - Metal  $\geq \frac{1}{4}$  " thick
    - Glass or acrylic  $\geq \frac{1}{2}$ " thick
  - **Edges**
    - Shall be straight and smooth with in  $\frac{1}{16}$ "

7

7

---

---

---

---

---

---

---

---

## **EQUIPMENT**

### **Mallet**

### **Scoop**

- **Size**
  - ~1.25  $\pm$  0.50 lb.  
Measure of  $\leq 0.5$  ft.<sup>3</sup>  
14 liters or smaller
  - ~2.25  $\pm$  0.50 lb.  
Measure of  $> 0.5$  ft.<sup>3</sup>
- **Head**
  - ~Rubber or Rawhide
- Large enough to obtain representative scoops of concrete.
- Small enough so concrete is not spilled during placement into the measure.



8

8

---

---

---

---

---

---

---

---

## **STANDARDIZATIONS**

- AASHTO R 18, states to standardize the measure every 12 months.
  - Mark the measure with an ID.
  - Record the volume of measure to 0.001 ft<sup>3</sup> in your quality control manual or report.

See the Appendix for more Information on how to Standardize a measure.

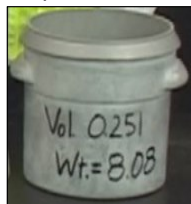

9

9

---

---

---

---

---

---

---

---

## **CONSOLIDATION**

Use the slump result and the chart below to determine to vibrate or rod the sample:

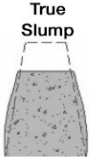

<b>Consolidation</b>	
<b>Slump</b>	<b>Consolidate by</b>
Less than 1"	Vibrate
1" to 3"	Rod or Vibrate
Greater than 3"	Rod

Procedure

10

10

---

---

---

---

---

---

---

---

## **SAMPLE**



Obtain the sample of freshly mixed concrete in accordance with AASHTO R60.

11

11

---

---

---

---

---

---

---

---

## **Procedure**

For this example, using a 0.25 ft<sup>3</sup> measure & slump is > 3 inches.

- Dampen the measure
  - Remove excess water
- Record the empty weight of the measure to 0.1 lb.
- Fill the measure in 3 equal layers
  - Move scoop around the perimeter while filling for even distribution of concrete.

12

12

---

---

---

---

---

---

---

---



### Procedure

- Consolidate each layer by rodding 25 times per lift.
  - Penetrate each previous lift by ~ 1 inch.
  - Tap each layer 10 – 15 times using a rubber mallet
    - Use enough force to close holes left by rodding.
- After consolidation, there should be about 1/8" (3mm) excess concrete above the top of the measure.
  - Adjust the top level if needed by adding or removing a representative portion of concrete.
  - Make all adjustments prior to strike off.

13

13

---

---

---

---

---

---

---

---

### After Rodding 25 times



### After Tapping 10-15 times Consolidated



14

14

---

---

---

---

---

---

---

---

### Strike off procedure



- Strike off the concrete by pressing the strike-off plate on the top surface of the measure to cover about **two thirds** of the surface and withdraw the plate towards the operator with a sawing motion to finish only the area originally covered.

15

15

---

---

---

---

---

---

---

---



- Then place the plate on the top of the measure to cover the original **two thirds** of the surface and advance it with a vertical pressure and a sawing motion away from the operator to cover the whole surface of the measure.

16

16

---

---

---

---

---

---

---

---



Finally, hold the plate at an incline and apply the final strokes to produce a smooth finished surface. Clean all excess concrete from the exterior of the measure including the rim.

17

17

---

---

---

---

---

---

---

---

### Record weight

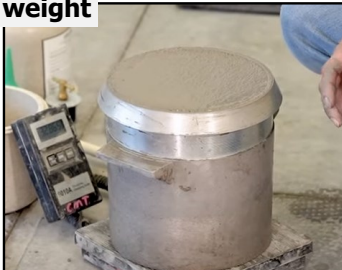

Determine the net mass of the concrete in the measure with a scale.

**Record the weight to the nearest 0.1 lb. (This is  $M_c$ )**

18

18

---

---

---

---

---

---

---

---

**PROCEDURE – Self Consolidating Concrete**

- Dampen the measure, weigh, **Record the weight to the nearest 0.1 lb.**
- Slightly overfill the measure in one continuous lift.
- Drop height ≤5 inches when filling measure.
- Do not Rod, Tap or Vibrate.
- Strike off, clean, weigh, **Record the weight to the nearest 0.1 lb.**



19

19

---

---

---

---

---

---

---

---

**PROCEDURE - VIBRATING**

- 2 layers or lifts using a scoop.
- Move the scoop around the perimeter of the measure while placing concrete.
- Insert the vibrator at **3** different points of each layer.
- Final layer, vibrate into lower layer ~ 1".
- Do not allow vibrator to touch the bottom or side of the measure.
- Avoid creating air pockets when removing vibrator.



Updated

20

20

---

---

---

---

---

---

---

---

**Internal Vibration steps cont. . .**

- When consolidating the bottom layer, do not allow the vibrator to touch the bottom or sides of the measure, and do not over vibrate.
- On the final layer, vibrate into the underlying layer approximately **1 inch**.
- Withdraw the vibrator without creating air pockets.
- Overfill by **1/8** inch above the top of the rim.
- Tap measure sharply **10-15** times with the appropriate mallet using enough force to close any voids left by the vibrator.
- Add or remove concrete as needed.
- Strike off with a glass plate. (See previous slides)

21

21

---

---

---

---

---

---

---

---

## CALCULATIONS

### **SYMBOLS:**

- A** = air content, %
- C** = actual cement content lb./yd<sup>3</sup> (kg/m<sup>3</sup>)
- C<sub>b</sub>** = mass of cement in the batch, lb. (kg)
- D** = density (unit weight) of concrete, lb./ft<sup>3</sup> (kg/m<sup>3</sup>)
- M** = total mass of all materials batched, lb. (kg)
- M<sub>c</sub>** = mass of the measure filled with concrete, lb. (kg)
- M<sub>m</sub>** = mass of the measure, lb. (kg)
- R<sub>y</sub>** = relative yield

22

22

---

---

---

---

---

---

---

---

### **SYMBOLS:**

- T** = Theoretical density of the concrete computed on an air free basis, lb./ft<sup>3</sup> (kg/m<sup>3</sup>).
- V** = Total absolute volume of the component ingredients in the batch, ft<sup>3</sup> (m<sup>3</sup>).
- V<sub>m</sub>** = Volume of the measure, ft<sup>3</sup> (m<sup>3</sup>).
- Y** = Yield, volume of concrete produced per batch, yd<sup>3</sup> or (m<sup>3</sup>).
- Y<sub>d</sub>** = Yield, volume of concrete that the batch was designed to produce, yd<sup>3</sup> or (m<sup>3</sup>).
- Y<sub>f</sub>** = Yield, volume of concrete produced per batch, ft.<sup>3</sup> (m<sup>3</sup>)

23

23

---

---

---

---

---

---

---

---

## CALCULATIONS

**Theoretical Density (T)** – The theoretical density is, customarily, a laboratory determination. The value for the theoretical density is assumed to remain constant for all batches made using identical component ingredients and proportions. It is calculated from the equation:

$$T = \frac{M}{V}$$

Report to the nearest 0.1 lb./ft<sup>3</sup>

24

24

---

---

---

---

---

---

---

---

• **Density (Unit Mass)**

- Calculate the net mass of the concrete in pounds by subtracting the mass of the measure ( $M_m$ ) from the gross mass ( $M_c$ ).
- Calculate the *density*, ( $D$ ), by dividing the net mass of the concrete by the volume of the measure ( $V_m$ ) as follows:

$$D = \frac{(M_c - M_m)}{V_m}$$

Report to the nearest 0.1 lb./ft<sup>3</sup>

25

25

---

---

---

---

---

---

---

---

- **Yield**, volume of concrete produced per batch, yd<sup>3</sup> or ft<sup>3</sup>.

For Yield in cubic yards

For Yield in cubic feet

$$Y \text{ (yd}^3\text{)} = \frac{M}{(D \times 27)}$$

$$Y \text{ (ft}^3\text{)} = \frac{M}{D}$$

$D$  = Density (unit weight) of concrete, kg/m<sup>3</sup> (lb./ft<sup>3</sup>)

$M$  = total mass of all materials batched, kg (lb.)

$27$  = The amount of cubic feet in a yd<sup>3</sup>

Report to the nearest 0.1 yd<sup>3</sup>, 0.1 ft<sup>3</sup>

26

26

---

---

---

---

---

---

---

---

- **Relative Yield** – Relative yield is the ratio of the actual volume of concrete obtained to the volume as designed for the batch calculated as follows.

$$R_y = \frac{Y}{Y_d}$$

Report to the nearest 0.1 ft<sup>3</sup>/yd<sup>3</sup>

**NOTE:** A value for  $R_y$  greater than **1.00** indicates an excess of concrete being produced, whereas a value less than this indicates the batch to be "short" of its designed volume. In practice, a ratio of yield in cubic feet per cubic yard of design concrete mixture is frequently used, for example, 27.3 ft<sup>3</sup>/yd<sup>3</sup>.

27

27

---

---

---

---

---

---

---

---

- **Cement Content:** Calculate the actual cement content as follows:

$$C = \frac{C_b}{Y}$$

C = actual cement content kg/m<sup>3</sup> (lb./yd<sup>3</sup>)

C<sub>b</sub> = mass of cement in the batch, kg (lb.)

Y = yield, volume of concrete produced per batch, m<sup>3</sup> or (yd<sup>3</sup>)

Report to the nearest whole 1 lbs./yd<sup>3</sup>.

28

28

---

---

---

---

---

---

---

---

- **Air Content** – Calculate the air content as follows:

$$A = \frac{(T - D) \times 100}{T}$$

T = theoretical density of the concrete computed on an air free basis, kg/m<sup>3</sup> (lb./ft<sup>3</sup>).

D = density (unit weight) of concrete, kg/m<sup>3</sup> (lb./ft<sup>3</sup>).

(lb./ft<sup>3</sup>) also abbreviated as **pcf** = pounds per cubic foot.

Report to the nearest 0.1%.

29

29

---

---

---

---

---

---

---

---

## REPORT

- **Identification of concrete** represented by the sample.
- **Date of test**
- **Volume of density measure** to the nearest **0.001 ft<sup>3</sup>**
- **Density** (Unit Weight) to the nearest **0.1 lb./ft<sup>3</sup>**
- **Yield**, when requested, to the nearest **0.1 yd<sup>3</sup>**
- **Relative Yield**, when requested to the nearest **0.01**
- **Cement Content**, when requested to the nearest **lb./yd<sup>3</sup>**
- **Air Content**, when requested, to the nearest **0.1 %**.

30

30

---

---

---

---

---

---

---

---

### Classroom - Exercise

- A batch design of **9.0 yd<sup>3</sup>**, with a total of **34,850 lbs.** of materials, with a theoretical density of **142.5 lb./ft<sup>3</sup>**, using a **0.500 ft<sup>3</sup>** measure weighing **19.8 lbs.**, when filled with concrete the measure weighs **90.7 lbs.**
- Calculate the following:
  1. **Density**
  2. **Yield per batch in yd<sup>3</sup>**
  3. **Yield per batch in ft<sup>3</sup>**
  4. **Yield per batch ft<sup>3</sup>/ yd<sup>3</sup>**
  5. **All Relative Yield calculations**
  6. **Air Content**

31

31

---

---

---

---

---

---

---

---

#### 1. Density

ANSWER

$$D = \frac{M_c - M_m}{V_m}$$

- $M_c = 90.7 \text{ lbs.}$
- $M_m = 19.8 \text{ lbs.}$
- $V_m = 0.500 \text{ ft}^3$

$$D = \frac{90.7 \text{ lbs.} - 19.8 \text{ lbs.}}{0.500 \text{ ft}^3} = 141.8 \text{ lb./ft}^3$$

Density (Unit Weight) is 141.8 lb./ft<sup>3</sup>

Report to the nearest 0.1 lb./ft<sup>3</sup>.

32

32

---

---

---

---

---

---

---

---

#### 2. Yield per batch in cubic yard, yd<sup>3</sup>

ANSWER

$$Y \text{ (yd}^3\text{)} = \frac{M}{(D \times 27)}$$

- $D = 141.8 \frac{\text{lbs.}}{\text{ft}^3}$
- $27 =$  The amount of cubic feet in a yd<sup>3</sup>
- $M = 34,850$  total weight of materials

$$Y \text{ (yd}^3\text{)} = \frac{34,850 \text{ lbs.}}{141.8 \frac{\text{lbs.}}{\text{ft}^3} \times 27 \frac{\text{ft}^3}{\text{yd}^3}} = 9.10 = 9.1 \text{ yd}^3$$

Report to the nearest 0.1 yd<sup>3</sup>.

33

33

---

---

---

---

---

---

---

---

3. Yield per batch in cubic feet, ft<sup>3</sup> ANSWER

$$Y \text{ (ft}^3\text{)} = \frac{M}{D}$$

- D = 141.8  $\frac{\text{lbs.}}{\text{ft}^3}$
- M = 34,850 lbs.

$$Y \text{ (ft}^3\text{)} = \frac{34,850 \text{ lbs.}}{141.8 \frac{\text{lbs.}}{\text{ft}^3}} = 245.8 \text{ ft}^3$$

Report to the nearest 0.1 ft<sup>3</sup>.

**34**

34

---

---

---

---

---

---

---

---

4. Yield in ft<sup>3</sup> per yd<sup>3</sup> ANSWER

$$\text{Yield per Batch} = \frac{Y \text{ (ft}^3\text{)}}{Y \text{ (yd}^3\text{)}_{\text{Design}}}$$

$$\text{Yield per Batch} = \frac{245.8 \text{ ft}^3}{9.0 \text{ yd}^3} = 27.31 = 27.3 \frac{\text{ft}^3}{\text{yd}^3}$$

Report to the nearest 0.1 ft<sup>3</sup>/yd<sup>3</sup>.

**35**

35

---

---

---

---

---

---

---

---

5. All Relative Yield calculations ANSWER

**R<sub>y</sub> using cubic yards**

- Y = 9.1 yd<sup>3</sup>
- Y<sub>d</sub> = 9.0 yd<sup>3</sup>

$$R_y = \frac{Y}{Y_d} = \frac{9.1 \text{ yd}^3}{9.0 \text{ yd}^3} = 1.01$$

**R<sub>y</sub> using cubic feet**

- Y = 245.8 ft<sup>3</sup>
- Y<sub>f</sub> = 243.0 ft<sup>3</sup>

$$R_y = \frac{Y}{Y_d} = \frac{245.8 \text{ ft}^3}{243.0 \text{ ft}^3} = 1.01$$

9 x 27 = 243

**R<sub>y</sub> using cubic feet / cubic yard**

- Y = 27.3 ft<sup>3</sup>/yd<sup>3</sup>
- Y<sub>df</sub> = 27.0 ft<sup>3</sup>/yd<sup>3</sup>

$$R_y = \frac{Y}{Y_d} = \frac{27.3 \text{ ft}^3/\text{yd}^3}{27.0 \text{ ft}^3/\text{yd}^3} = 1.01$$

Report to the nearest whole 0.01

**36**

36

---

---

---

---

---

---

---

---



6. Gravimetric Air Content

ANSWER

$$A = \frac{(T - D) \times 100}{T}$$

T = 142.5 pcf  
 D = 141.8 pcf  
 pcf = (lb./ft<sup>3</sup>)

$$A = \frac{(142.5 - 141.8)}{142.5} \times 100 = 0.491 = 0.5\%$$

Report to the nearest 0.1%.

37

37

---

---

---

---

---

---

---

---

Calculate the Cement Content – Practice Problem

$$C = \frac{C_b}{Y}$$

Design = 7 yd<sup>3</sup>

Y = 7.2 yd<sup>3</sup>

Mix = 6.5 sack mix (611 lbs./yd<sup>3</sup>)

C<sub>b</sub> = 4,330 lbs. of cement batched

Report to the nearest whole 1 lbs./yd<sup>3</sup>.

38

38

---

---

---

---

---

---

---

---

Cement Content

ANSWER

Design = 7 yd<sup>3</sup>

Y = 7.2 yd<sup>3</sup>

Mix = 6.5 sack mix (611 lbs./yd<sup>3</sup>)

C<sub>b</sub> = 4,330 lbs. of cement batched

$$C = \frac{C_b}{Y}$$

Report to nearest whole number.

$$C = \frac{4,330 \text{ lbs.}}{7.2 \text{ yd}^3} = 601.38 = 601 \text{ lbs./yd}^3$$

39

39

---

---

---

---

---

---

---

---

**Classroom – Exercise – on your own**

- A batch design of **7.0 yd<sup>3</sup>**, with a total of **27,878 lbs.** of materials, and a theoretical density of **146.4 lb./ft<sup>3</sup>**, using a **0.500 ft<sup>3</sup>** measure weighing **19.5 lbs.**, when filled with concrete the measure weighs **91.2 lbs.**
- Calculate the following:
  1. Density
  2. Yield per batch in yd<sup>3</sup>
  3. Yield per batch in ft<sup>3</sup>
  4. Yield per batch ft<sup>3</sup>/ yd<sup>3</sup>
  5. All Relative Yield calculations
  6. Air Content

40

40

---

---

---

---

---

---

---

---

**Answers**

1. Density = 143.4 lb./ft<sup>3</sup>
2. Yield per batch in cubic yard = 7.2 yd<sup>3</sup>
3. Yield per batch in cubic feet = 194.4 ft<sup>3</sup>
4. Yield per batch in ft<sup>3</sup> per yd<sup>3</sup> = 27.8  $\frac{\text{ft}^3}{\text{yd}^3}$
5. All yields = 1.03
6. Air Content = 2.0%

41

41

---

---

---

---

---

---

---

---

**Calculate the Cement Content – on your own**

$$C = \frac{C_b}{Y}$$

9 yd<sup>3</sup> (designed)

Yield = 9.3 yd<sup>3</sup>

6.5 sack mix (611 lbs./yd<sup>3</sup>)

5,499 lbs. of cement batched

Report to the nearest whole 1 lbs./yd<sup>3</sup>.

42

42

---

---

---

---

---

---

---

---

**Cement Content - Answer**

$$C = \frac{C_b}{Y}$$

$$C = \frac{5,499 \text{ lbs.}}{9.3 \text{ yd}^3} = 591 \text{ lbs./yd}^3$$

43

---

---

---

---

---

---

---

43

### CONSOLIDATION

Use the slump result and the chart below to determine to vibrate or rod the sample:

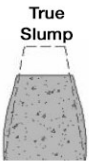

True Slump

Consolidation	
Slump	Consolidate by
Less than 1"	Vibrate
1" to 3"	Rod or Vibrate
Greater than 3"	Rod

Procedure 1

1

### SAMPLE



Obtain the sample of freshly mixed concrete in accordance with AASHTO R 60.

2

2

### PROCEDURE - RODDING

For procedure, using a 0.250 ft<sup>3</sup> measure & slump is > 3 inches:



- Dampen the inside of the pot and Remove excess water.

3

3



- Weigh and record the empty weight of the measure. Record to nearest 0.1 lb.

4

4

### LIFT 1



Place the measure on a firm, flat, level surface. Fill the measure in **3 equal layers**. Move the scoop around the perimeter while filling to obtain an even distribution of concrete.

5

5

### Consolidation by Rodding:

- Rod each lift based on the size of the measure:

Today we are using a 0.25 ft<sup>3</sup> measure.

Rod/Lift	Size of Measure	Mallet Size
25	≤ 0.5 ft <sup>3</sup>	1.25 ± 0.5 lb.
50	1.0 ft <sup>3</sup>	2.25 ± 0.5 lb.
1/3 in <sup>2</sup> Area	> 1.0 ft <sup>3</sup>	2.25 ± 0.5 lb.

- Rod **25** times each lift.
- Mallet size will be 1.25 lb.

6

6

**LIFT 1**

**ROD 25 TIMES**



Rod the bottom layer throughout its depth but do not forcibly strike the bottom of the measure. Distribute the strokes uniformly over the cross section of the measure.

7

**LIFT 1**

**Use mallet 10 - 15 X**





- With a mallet tap around the perimeter 10 - 15 times after each lift. Use enough force to close voids left by the tamping rod and release trapped air bubbles

8

**LIFT 2**

**2<sup>nd</sup> LIFT Fill Height 2/3 Volume**





Rod **25 times** into the underlying layer about **1 inch**. Then tap 10 - 15 times with a mallet.

9

**LIFT 3**



**3rd LIFT OVERFILL By 1/8" Volume**

Rod **25 times** into the underlying layer about **1 inch**. Then tap 10 - 15 times with a mallet.

10

**After Rodding 25 times**      **After Tapping 10-15 times Consolidated**





After consolidation, adjust the top level if needed by adding or removing a representative portion of concrete. Make all adjustments prior to strike-off.

11

**DENSITY**

**STRIKEOFF**



- Strike off the concrete by pressing the strike-off plate on the top surface of the measure to cover about **two thirds** of the surface and withdraw the plate towards the operator with a sawing motion to finish only the area originally covered.

12

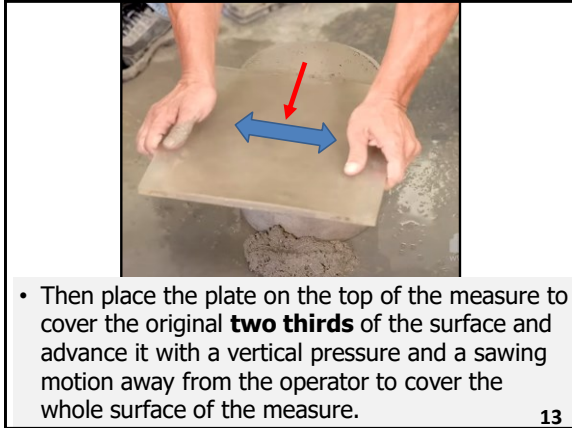

- Then place the plate on the top of the measure to cover the original **two thirds** of the surface and advance it with a vertical pressure and a sawing motion away from the operator to cover the whole surface of the measure.

13

13

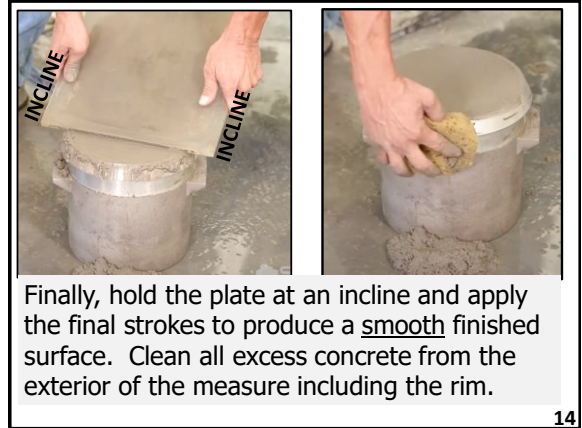

Finally, hold the plate at an incline and apply the final strokes to produce a smooth finished surface. Clean all excess concrete from the exterior of the measure including the rim.

14

14

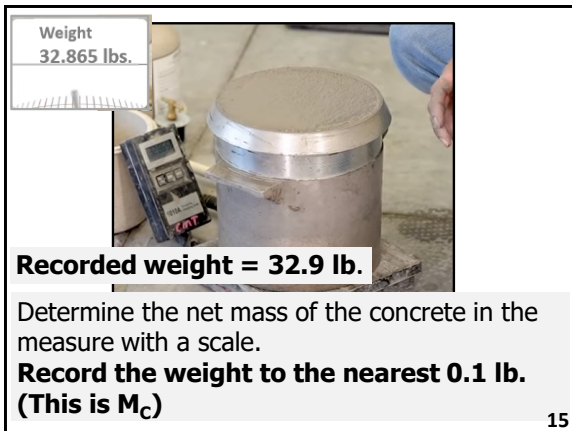

**Recorded weight = 32.9 lb.**

Determine the net mass of the concrete in the measure with a scale.

**Record the weight to the nearest 0.1 lb. (This is  $M_c$ )**

15

15

CONCRETE – UNIT WEIGHT – **WORKSHEET** – AASHTO T121M

**Y<sub>d</sub>** = Batch Design: \_\_\_\_\_ yd<sup>3</sup>

**M** = Total Mass of weighed materials: \_\_\_\_\_ lbs.

**T** = Theoretical Density: \_\_\_\_\_ lbs./ft<sup>3</sup>

**V<sub>m</sub>** = 0.500 ft<sup>3</sup> measure

**M<sub>m</sub>** = Measure weighs: \_\_\_\_\_ lbs.

**M<sub>c</sub>** = Measure filled with concrete: \_\_\_\_\_ lbs.

---

1. **Density**     **D** =  $\frac{M_c - M_m}{V_m}$

(Report to **0.1** lbs./ft<sup>3</sup>)

---

2. Yield per batch in cubic yards     **Y (yd<sup>3</sup>)** =  $\frac{M}{(D \times 27)}$

(Report to **0.1** yd<sup>3</sup>)

---

3. Yield per batch in cubic feet     **Y (ft<sup>3</sup>)** =  $\frac{M}{D}$

(Report to **0.1** ft<sup>3</sup>)

---

4. Yield per batch cubic foot per cubic yard     **Y** =  $\frac{Y(\text{ft}^3)}{Y_d (\text{Yd}^3) \text{ design}}$

(Report to **0.1** ft<sup>3</sup>/yd<sup>3</sup>)

---

5. Relative Yield in cubic yards     **R<sub>y</sub>** =  $\frac{Y (\text{yd}^3)}{Y_d (\text{yd}^3) \text{ design}}$

(Report to **0.01**)

---

6. Air content     **A** =  $\frac{(T - D)}{T} \times 100$

(Report to **0.1**%)





CONCRETE – UNIT WEIGHT – **WORKSHEET** – AASHTO T121M

**Y<sub>d</sub>** = Batch Design: \_\_\_\_\_ yd<sup>3</sup>

**M** = Total Mass of weighed materials: \_\_\_\_\_ lbs.

**T** = Theoretical Density: \_\_\_\_\_ lbs./ft<sup>3</sup>

**V<sub>m</sub>** = 0.500 ft<sup>3</sup> measure

**M<sub>m</sub>** = Measure weighs: \_\_\_\_\_ lbs.

**M<sub>c</sub>** = Measure filled with concrete: \_\_\_\_\_ lbs.

---

1. **Density**     **D** =  $\frac{M_c - M_m}{V_m}$

(Report to **0.1** lbs./ft<sup>3</sup>)

---

2. Yield per batch in cubic yards     **Y (yd<sup>3</sup>)** =  $\frac{M}{(D \times 27)}$

(Report to **0.1** yd<sup>3</sup>)

---

3. Yield per batch in cubic feet     **Y (ft<sup>3</sup>)** =  $\frac{M}{D}$

(Report to **0.1** ft<sup>3</sup>)

---

4. Yield per batch cubic foot per cubic yard     **Y** =  $\frac{Y(\text{ft}^3)}{Y_d (\text{Yd}^3) \text{ design}}$

(Report to **0.1** ft<sup>3</sup>/yd<sup>3</sup>)

---

5. Relative Yield in cubic yards     **R<sub>y</sub>** =  $\frac{Y (\text{yd}^3)}{Y_d (\text{yd}^3) \text{ design}}$

(Report to **0.01**)

---

6. Air content     **A** =  $\frac{(T - D)}{T} \times 100$

(Report to **0.1**%)



CONCRETE – UNIT WEIGHT – **WORKSHEET** – AASHTO T121M

**Y<sub>d</sub>** = Batch Design: \_\_\_\_\_ yd<sup>3</sup>

**M** = Total Mass of weighed materials: \_\_\_\_\_ lbs.

**T** = Theoretical Density: \_\_\_\_\_ lbs./ft<sup>3</sup>

**V<sub>m</sub>** = 0.500 ft<sup>3</sup> measure

**M<sub>m</sub>** = Measure weighs: \_\_\_\_\_ lbs.

**M<sub>c</sub>** = Measure filled with concrete: \_\_\_\_\_ lbs.

---

1. **Density**     **D** =  $\frac{M_c - M_m}{V_m}$

(Report to **0.1** lbs./ft<sup>3</sup>)

---

2. Yield per batch in cubic yards     **Y (yd<sup>3</sup>)** =  $\frac{M}{(D \times 27)}$

(Report to **0.1** yd<sup>3</sup>)

---

3. Yield per batch in cubic feet     **Y (ft<sup>3</sup>)** =  $\frac{M}{D}$

(Report to **0.1** ft<sup>3</sup>)

---

4. Yield per batch cubic foot per cubic yard     **Y** =  $\frac{Y(\text{ft}^3)}{Y_d (\text{Yd}^3) \text{ design}}$

(Report to **0.1** ft<sup>3</sup>/yd<sup>3</sup>)

---

5. Relative Yield in cubic yards     **R<sub>y</sub>** =  $\frac{Y (\text{yd}^3)}{Y_d (\text{yd}^3) \text{ design}}$

(Report to **0.01**)

---

6. Air content     **A** =  $\frac{(T - D)}{T} \times 100$

(Report to **0.1**%)



# AASHTO T121M: Density (Unit Weight), Yield, and Air Content (Gravimetric) of Concrete

## PROFICIENCY CHECKLIST

Applicant \_\_\_\_\_

Employer \_\_\_\_\_

	Trial #	1	2
<b>Standardize</b>			
Mass and volume of empty measure determined in yearly standardization.			
<b>Sample</b>			
Obtained sample in accordance with AASHTO R60.			
<b>Procedure – Rodding – Rod 25 or (50) times according to size of the measure</b>			
1. Determined which consolidation method to use from the slump.			
2. Determine which size measure and size mallet to use from the nominal maximum size of the aggregate. (Use chart)			
3. Dampened the measure, weigh to 0.1 lbs., and place on a flat, level, firm surface.			
4. Weigh and record empty measure to nearest 0.1 lbs.			
5. Scooped representative sample of concrete into the measure, moving the scoop around the perimeter to fill the measure in 3 equal layers.			
6. - <b>Bottom layer</b> , fill 1/3 full, rod 25 (50) times through without striking the bottom of the measure, tap 10-15 times with a mallet.  - <b>2<sup>nd</sup> layer</b> , fill 2/3 full, rod 25 (50) times 1 inch into the bottom layer, tap 10-15 times with a mallet.  - <b>3<sup>rd</sup> layer</b> , overfill by 1/8 inch and rod 25 (50) times 1 inch into the 2 <sup>nd</sup> layer, tap 10-15 times with a mallet.			
7. Ensure proper consolidation has been achieved.			
8. If needed adjust the concrete by adding or removing concrete to be 1/8 inch overfill.			
9. Ensure proper consolidation has been achieved.			
<b>Procedure - Vibration</b>			
10. <b>For internal vibration</b> , measure filled in <b>2</b> equal layers.			
11. Vibrated each layer at <b>3</b> different points.			
12. Ensured proper consolidation has been achieved.			
<b>Finishing</b>			
13. Use a glass plate for strike off method, ending with a smooth finish.			
14. Clean the outside of the measure and the rim			
15. Weigh and record the full measure to the nearest 0.1 lbs.			
16. Calculate Density (unit weight), report to nearest 0.1 lb./ft <sup>3</sup>			
17. When requested, report: Yield, Relative Yield, Cement Content, and Gravimetric Air Content.			

PASS    PASS

Examiner: \_\_\_\_\_ Date: \_\_\_\_\_

FAIL    FAIL



# **AASHTO T196M**

ASTM C173

## **Air Content of Freshly Mixed Concrete by the Volumetric Method**

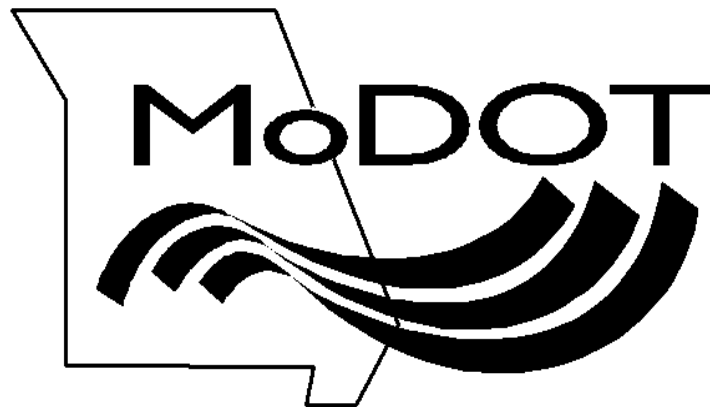





**AASHTO T196M**  
**Air Content**  
**of**  
**Freshly Mixed Concrete**  
**by the Volumetric Method**



UPDATED

Rev 10/24/2024

1

---

---

---

---

---

---

---

---

**SCOPE**

- This test method covers determination of the air content of freshly mixed concrete containing any type of aggregate
  - Dense
  - Cellular
  - Lightweight.

2

2

---

---

---

---

---

---

---

---

**TERMINOLOGY**

- **Air-Content:** The amount of air in mortar or concrete, exclusive of pore space in the aggregate particles, usually expressed as a percentage of total volume of mortar or concrete.

3

3

---

---

---

---

---

---

---

---

### **SIGNIFICANCE AND USE**

- This test covers the determination of the air content of freshly mixed concrete. It measures the air contained in the mortar fraction of the concrete but is not affected by air that may be present inside porous aggregate particles. Therefore, this is the appropriate test to determine the air content of concretes containing lightweight aggregates, air-cooled slag, and highly porous or vesicular natural aggregates.

4

4

---

---

---

---

---

---

---

---

- This test method requires the addition of sufficient isopropyl alcohol, when the meter is initially being filled with water, so that after the first or subsequent rolling, little or no foam collects in the neck of the top section of the meter.
- If more foam is present than that equivalent to **2%** air above the water level, the test is declared invalid and must be repeated using a larger quantity of alcohol.
- Addition of alcohol to dispel foam any time after the initial filling of the meter to the zero mark is not permitted.

Significance and Use

5

5

---

---

---

---

---

---

---

---

- The air content of hardened concrete may be either higher or lower than that determined by this test method.
  - Depends on the methods and amounts of consolidation effort applied to the concrete from which the hardened concrete specimen is taken.
  - Uniformity and stability of the air bubbles in the fresh and hardened concrete.
  - Accuracy of the microscopic examination, if used.
  - Time of comparison
  - Environmental exposure

Significance and Use

6

6

---

---

---

---

---

---

---

---

- Stage in the delivery, placement, and consolidation processes at which the air content of the unhardened concrete is determined, that is, before or after the concrete goes through a pump.
- Other factors

Significance and Use

7

7

---

---

---

---

---

---

---

---

### APPARATUS

- Air Meter (Roll-a-Meter)
  - The top section of the meter shall be at least 20% larger than the measuring bowl
- Funnel
- Tamping Rod
- Strike-off Bar
- Standardized Cup
- Measuring Vessel for Isopropyl Alcohol
- Syringe
- Pouring Vessel for Water
- Scoop
- Isopropyl Alcohol
- **NOTE: See the Appendix for additional information on Apparatus**



8

8

---

---

---

---

---

---

---

---

**Numbers get larger  
As you go down the tube.**

Watertight Cap

Graduations at least 0.5% increments that cover a range of 0 to 9% of bowl Volume.

Rubber gasket  
For a watertight seal.

Measuring bowl  
or bowl

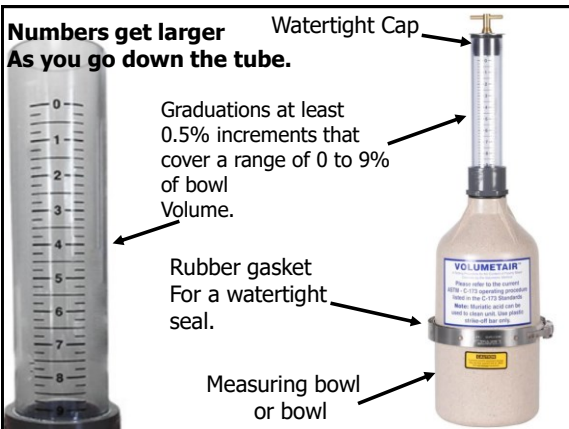

9

---

---

---

---

---

---

---

---

## CALIBRATION

- Calibrate the meter and standardized cup initially and at three-year intervals or whenever there is reason to suspect damage or deformation of the meter or calibrated cup.
- **See the Appendix** for calibration of the Air Meter or (Roller Meter).

10

10

---

---

---

---

---

---

---

---

## SAMPLING

- Obtain a sample of freshly mixed concrete in accordance with AASHTO R 60.
- If the concrete contains coarse aggregate particles that would be retained on a **1 1/2** inch sieve, wet-sieve a representative sample over a **1-inch** sieve to yield somewhat more than enough material to fill the measuring bowl.
- **NOTE:** Wet-sieving procedure is described in AASHTO R 60.

11

11

---

---

---

---

---

---

---

---

## PROCEDURE

- Mix the sample in the wheelbarrow.
- Dampen the inside of the bowl and dry it to a damp, not shiny, appearance.



Bowl = Measuring Bowl

12

12

---

---

---

---

---

---

---

---

- Using the scoop, fill the bowl in **2** equal layers.
- Rod each layer **25 times** and tap sides **10-15 times** with a mallet.
  - **1<sup>st</sup>** layer, fill halfway, and rod 25 times, without striking the bottom, tap 10 – 15 times.
  - **2<sup>nd</sup>** layer, overfill by  $\frac{1}{8}$ ", rod 25 times, **1 inch** into the bottom layer, tap 10 – 15 times.

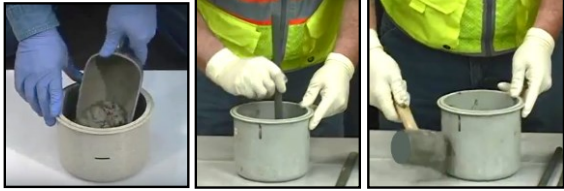

Procedure

13

13

---

---

---

---

---

---

---

---

---

---

- If needed, add or remove concrete to obtain approximately  $\frac{1}{8}$  inch of concrete above the rim of the bowl.
- Strike off the surface to be flush with the top of the bowl using a strike-off bar.
- Clean bowl flange.



Procedure

14

14

---

---

---

---

---

---

---

---

---

---



- Wet the top portion of the Roll-a-Meter and gasket and clamp the top on to the bowl for a watertight seal.

15

15

---

---

---

---

---

---

---

---

---

---



- Insert the funnel through the top and add at least **0.5 L (1 pint)** of water.

16

16

---

---

---

---

---

---

---

---

- Add the selected amount of 70% isopropyl alcohol. Record the amount of alcohol added.

**NOTE:**

Add the amount of isopropyl alcohol necessary to obtain a stable reading and a minimum of foam at the top of the water column.



- A typical amount is 1,000ml or 2 pints.
- Larger amounts will need less initial water

17

17

---

---

---

---

---

---

---

---

- Then add the **2<sup>nd</sup>** amount of water up to the zero mark.

- Pull out the funnel.

- Fine tune the liquid level (adding or subtracting liquid) with a syringe until the bottom of the meniscus is on the zero mark.

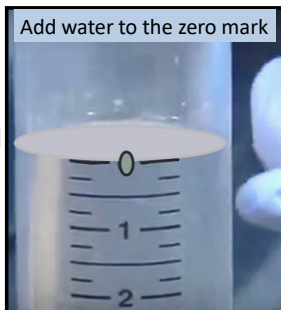

Procedure

18

18

---

---

---

---

---

---

---

---

- Put the cap on and tighten.



Shake to free the concrete from the Measuring bowl.



- Invert the meter
- Shake horizontally
- No more than 5 seconds at a time.
- Return meter to an upright position.
- Repeat; invert, shake 5 sec., back to upright position.
- Repeat up to a max of 45 seconds total.

Procedure

19

19

---

---

---

---

---

---

---

---



**Rolling Procedure:**

- Tilt meter to 45° angle on floor or table.
- Vigorously roll the meter ¼ to ½ turn back and forth.
- Rotate the base 1/3 turn
- Continue rolling and turning for approximately 1 minute.
  - Aggregate must be heard sliding in the base.

20

---

---

---

---

---

---

---

---

- If, at any time, during the inversion and rolling procedure liquid is found to be leaking from the meter, the test is considered **invalid**, and a new test shall be started on a new sample.

Procedure

21

21

---

---

---

---

---

---

---

---

- Set the unit upright.
- Loosen the top.
- Allow any pressure to stabilize while the air rises to the top and until the liquid level stabilizes.
- The liquid level is considered stable when does not change more than **0.25%** air within **2-minute** period.

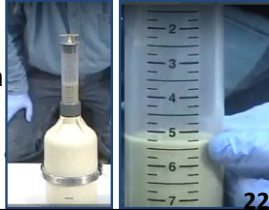
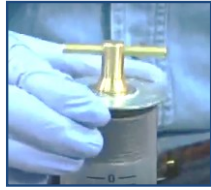

22

22

---

---

---

---

---

---

---

---

- If it takes more than **6 minutes** for the liquid level to stabilize or if there is more foam than that equivalent to **2** full percent air content divisions on the meter scale over the liquid level, **discard** the trial and **start a new test** on a new sample of concrete.
  - Use a larger addition of alcohol than used in the initial testing.
- If the level is stable without excessive foam, read the bottom of the meniscus to the nearest **0.25%** and record the initial meter reading.

Procedure

23

23

---

---

---

---

---

---

---

---

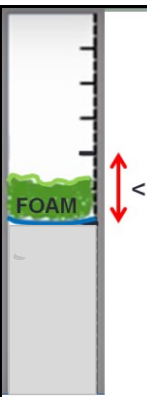

**1<sup>st</sup> reading:**

- Less than **2%** increments of foam above water line.
- Must be stable within **6** minutes.

Stable Reading:

Drops  $< \frac{1}{4}\%$  in 2 minutes.

$\frac{1}{4} \% = 0.25\%$

Procedure

24

24

---

---

---

---

---

---

---

---



- If the air content is greater than the **9%** range of the meter, the water level will not appear in the graduated neck of the meter. To fix this, add enough standardized cups of water to bring the liquid level within the graduate range.
- Record the number of standardized cups added to get the water up into the graduated neck of the meter.
- Read the bottom of the meniscus to the nearest **0.25%**.

Procedure

25

25

---

---

---

---

---

---

---

---

- Record the number of standardized cups of water to be added to the final meter reading.



Procedure

26

26

---

---

---

---

---

---

---

---

**Confirmation of the Initial Meter Reading**

- When an initial meter reading is obtained, retighten the top and repeat the **1-minute** rolling procedure.



Second Rolling Procedure

Procedure

27

27

---

---

---

---

---

---

---

---

- When the liquid level is stable on the 2<sup>nd</sup> rolling, make a direct reading to the bottom of the meniscus and estimate to **0.25%** air.
- If this reading has not changed more than **0.25%** from the initial meter reading, record it as the final meter reading of the sample tested.
- However, if the reading has changed from the initial meter reading by more than **0.25%** air, record this reading as the NEW "initial reading" and repeat the 1-minute rolling for a 3<sup>rd</sup> time.

28

28

---

---

---

---

---

---

---

---

- Read the indicated air content. If this reading has not changed by more than **0.25%** air from the NEW "initial reading" record it as the final meter reading.
- If the reading has changed by more than **0.25%**, discard the test and start a new test on a new sample of concrete using more alcohol.

Procedure

29

29

---

---

---

---

---

---

---

---

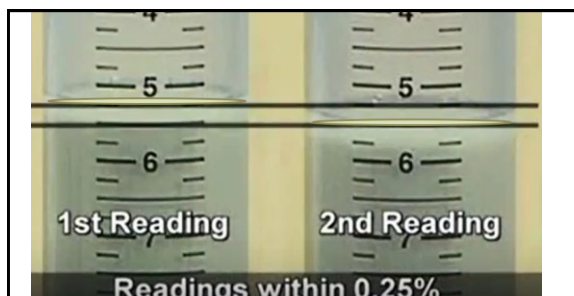

**1<sup>st</sup> reading is 5.25%, 2<sup>nd</sup> reading is 5.50%**  
**readings are within 0.25%**  
**therefore the 2<sup>ND</sup> reading is the final reading**  
**5.50% = Air Content**

Procedure

30

30

---

---

---

---

---

---

---

---

- Take the cap off and pour out the liquid.
- Disassemble the apparatus and examine the contents to be sure that there are no portions of undisturbed, tightly packed concrete in the base.



Procedure

31

31

---

---

---

---

---

---

---

---

**The measuring bowl should empty with no clumps left.**



If portions of undisturbed concrete are found, the test is **invalid!**

Procedure

32

32

---

---

---

---

---

---

---

---

### **CALCULATIONS - REPORTING**

- If more than 1.25L (2.5 pt.) of alcohol was used, correct the final meter reading.
- Round the volume of alcohol used to the nearest 0.5 L (1 pt.) and select the correction factor from Table 1.

Report air content to the nearest **0.25 percent air**.

Calculate the Air Content:

$$A = A_R - C + W$$

A = air content, percent

A<sub>R</sub> = final meter reading, percent

C = correction factor from Table 1, percent, and

W = number of standardized cups of water added to the meter. **33**

33

---

---

---

---

---

---

---

---

**Table 1: Correction for the Effect of Isopropyl Alcohol on Air Meter Reading**

PINTS of Alcohol	Ounces of Alcohol	Liters of Alcohol	Correction (subtract) <sup>a</sup>
≤ 2.0	≤ 32	≤ 1.0	0.00 <sup>b</sup>
3.0	48	1.5	0.25
4.0	64	2.0	0.50
5.0	80	2.5	0.75

34

34

---

---

---

---

---

---

---

---

**Table 1 added information:**

- **a** = Subtract from final meter reading.
- **b** = Corrections less than 0.125 are not significant and are to be applied only when 1.2L (2.5 pints) or more alcohol is used.
- The values given are for air meters with a measuring bowl volume of 2.1L (0.075ft<sup>3</sup>) and a top section that is 1.2 times the volume of the measuring bowl.

Calculation

35

35

---

---

---

---

---

---

---

---

**Practice #1**

**INTRODUCING A NEW FORMAT FOR CALCULATING AIR CONTENT**

Calculate the reported air content (volumeter) of the concrete.

PINTS of Alcohol	Ounces of Alcohol	Liters of Alcohol	Correction (subtract) <sup>a</sup>
≤ 2.0	≤ 32	≤ 1.0	0.00 <sup>b</sup>
3.0	48	1.5	0.25
4.0	64	2.0	0.50
5.0	80	2.5	0.75

Initial meter reading      6.50  
 Final meter reading      6.75  
 Pints of alcohol used      1.5  
 Alcohol content correction      \_\_\_\_\_ SUBTRACT  
 Calibrated cups of water added      0 ADD  
 Reported air content      \_\_\_\_\_ %



NOTE: Report air to the nearest 0.25%

36

36

---

---

---

---

---

---

---

---

**Practice #1** **ANSWER**

Calculate the reported air content (volumeter) of the concrete.

PINTS of Alcohol	Ounces of Alcohol	Liters of Alcohol	Correction (subtract)*
≤ 2.0	≤ 32	≤ 1.0	0.00 <sup>b</sup>
3.0	48	1.5	0.25
4.0	64	2.0	0.50
5.0	80	2.5	0.75

Initial meter reading	6.50	
Final meter reading	6.75	
Pints of alcohol used	1.5	
Alcohol content correction	- 0	SUBTRACT
Calibrated cups of water added	0	ADD
Reported air content	6.75	%

Calculations
6.75
- 0
6.75
+ 0
6.75



---

---

---

---

---

---

---

---

---

---

37

**Practice #2** **Enlarged**

Calculate the reported air content (volumeter) of the concrete.

PINTS of Alcohol	Ounces of Alcohol	Liters of Alcohol	Correction (subtract)*
≤ 2.0	≤ 32	≤ 1.0	0.00 <sup>b</sup>
3.0	48	1.5	0.25
4.0	64	2.0	0.50
5.0	80	2.5	0.75

Initial meter reading	6.00	
Final meter reading	6.00	
Pints of alcohol used	3	
Alcohol content correction		SUBTRACT
Calibrated cups of water added	0	ADD
Reported air content		%

---

---

---

---

---

---

---

---

---

---

38

**Practice #2** **ANSWER**

Calculate the reported air content (volumeter) of the concrete.

PINTS of Alcohol	Ounces of Alcohol	Liters of Alcohol	Correction (subtract)*
≤ 2.0	≤ 32	≤ 1.0	0.00 <sup>b</sup>
3.0	48	1.5	0.25
4.0	64	2.0	0.50
5.0	80	2.5	0.75

Initial meter reading	6.00	
Final meter reading	6.00	
Pints of alcohol used	3	
Alcohol content correction	-0.25	SUBTRACT
Calibrated cups of water added	0	ADD
Reported air content	5.75	%

Calculations
6.00
- 0.25
5.75
+ 0
5.75



---

---

---

---

---

---

---

---

---

---

39

Practice #3 Enlarged

Calculate the reported air content (volumeter) of the concrete.

PINTS of Alcohol	Ounces of Alcohol	Liters of Alcohol	Correction (subtract)*
≤ 2.0	≤ 32	≤ 1.0	0.00 <sup>b</sup>
3.0	48	1.5	0.25
4.0	64	2.0	0.50
5.0	80	2.5	0.75

Initial meter reading	<u>7.75</u>
Final meter reading	<u>8.00</u>
Pints of alcohol used	<u>4</u>
Alcohol content correction	_____ SUBTRACT
Calibrated cups of water added	<u>3</u> ADD
Reported air content	_____ %

**40**

---

---

---

---

---

---

---

---

40

Practice #3 ANSWER

Calculate the reported air content (volumeter) of the concrete.

PINTS of Alcohol	Ounces of Alcohol	Liters of Alcohol	Correction (subtract)*
≤ 2.0	≤ 32	≤ 1.0	0.00 <sup>b</sup>
3.0	48	1.5	0.25
4.0	64	2.0	0.50
5.0	80	2.5	0.75

Initial meter reading	<u>7.75</u>
Final meter reading	<u>8.00</u>
Pints of alcohol used	<u>4</u>
Alcohol content correction	<u>-0.50</u> SUBTRACT
Calibrated cups of water added	<u>3</u> ADD
Reported air content	<u>10.50</u> %

Calculations

8.00	
- .50	
7.50	
+3.00	
10.50	

**41**

---

---

---

---

---

---

---

---

41

**Practice #1**

**INTRODUCING A NEW FORMAT FOR CALCULATING AIR CONTENT**

*Enlarged*

Calculate the reported air content (volumeter) of the concrete.

PINTS of Alcohol	Ounces of Alcohol	Liters of Alcohol	Correction (subtract) <sup>a</sup>
≤ 2.0	≤ 32	≤ 1.0	0.00 <sup>b</sup>
3.0	48	1.5	0.25
4.0	64	2.0	0.50
5.0	80	2.5	0.75

Initial meter reading	6.50	
Final meter reading	6.75	
Pints of alcohol used	1.5	
Alcohol content correction		SUBTRACT
Calibrated cups of water added	0	ADD
Reported air content		%



NOTE: Report air to the nearest **0.25%**

**Practice #1**

**ANSWER**

Calculate the reported air content (volumeter) of the concrete.

PINTS of Alcohol	Ounces of Alcohol	Liters of Alcohol	Correction (subtract) <sup>a</sup>
≤ 2.0	≤ 32	≤ 1.0	0.00 <sup>b</sup>
3.0	48	1.5	0.25
4.0	64	2.0	0.50
5.0	80	2.5	0.75

Initial meter reading	6.50	
Final meter reading	6.75	
Pints of alcohol used	1.5	
Alcohol content correction	- 0	SUBTRACT
Calibrated cups of water added	0	ADD
Reported air content	6.75	%



Calculations  
 6.75  
 - 0  
 -----  
 6.75  
 + 0.  
 -----  
 6.75



Enlarged

Practice #2

Calculate the reported air content (volumeter) of the concrete.

PINTS of Alcohol	Ounces of Alcohol	Liters of Alcohol	Correction (subtract) <sup>a</sup>
≤ 2.0	≤ 32	≤ 1.0	0.00 <sup>b</sup>
3.0	48	1.5	0.25
4.0	64	2.0	0.50
5.0	80	2.5	0.75

Initial meter reading	6.00	
Final meter reading	6.00	
Pints of alcohol used	3	
Alcohol content correction		SUBTRACT
Calibrated cups of water added	0	ADD
Reported air content		%

38

Practice #2

ANSWER

Calculate the reported air content (volumeter) of the concrete.

PINTS of Alcohol	Ounces of Alcohol	Liters of Alcohol	Correction (subtract) <sup>a</sup>
≤ 2.0	≤ 32	≤ 1.0	0.00 <sup>b</sup>
3.0	48	1.5	0.25
4.0	64	2.0	0.50
5.0	80	2.5	0.75

Initial meter reading	6.00	
Final meter reading	6.00	
Pints of alcohol used	3	
Alcohol content correction	-0.25	SUBTRACT
Calibrated cups of water added	0	ADD
Reported air content	5.75	%

Calculations  
 6.00  
 - 0.25  
 -----  
 5.75  
 + 0  
 -----  
 5.75



39



Enlarged

Practice #3

Calculate the reported air content (volumeter) of the concrete.

PINTS of Alcohol	Ounces of Alcohol	Liters of Alcohol	Correction (subtract) <sup>a</sup>
≤ 2.0	≤ 32	≤ 1.0	0.00 <sup>b</sup>
3.0	48	1.5	0.25
4.0	64	2.0	0.50
5.0	80	2.5	0.75

Initial meter reading	<u>7.75</u>	
Final meter reading	<u>8.00</u>	
Pints of alcohol used	<u>4</u>	
Alcohol content correction	<u>          </u>	SUBTRACT
Calibrated cups of water added	<u>3</u>	ADD
Reported air content	<u>          </u>	%

40

Practice #3

ANSWER

Calculate the reported air content (volumeter) of the concrete.

PINTS of Alcohol	Ounces of Alcohol	Liters of Alcohol	Correction (subtract) <sup>a</sup>
≤ 2.0	≤ 32	≤ 1.0	0.00 <sup>b</sup>
3.0	48	1.5	0.25
4.0	64	2.0	0.50
5.0	80	2.5	0.75

Initial meter reading	<u>7.75</u>	
Final meter reading	<u>8.00</u>	
Pints of alcohol used	<u>4</u>	
Alcohol content correction	<u>-0.50</u>	SUBTRACT
Calibrated cups of water added	<u>3</u>	ADD
Reported air content	<u>10.50</u>	%

Calculations

$$\begin{array}{r}
 8.00 \\
 - .50 \\
 \hline
 7.50 \\
 +3.00 \\
 \hline
 10.50
 \end{array}$$

41



# AASHTO T196M: Air Content of Freshly Mixed Concrete by the Volumetric Method

## PROFICIENCY CHECKLIST

Applicant \_\_\_\_\_

Employer \_\_\_\_\_

	Trial #	1	2
<b>Sample</b>			
1. Obtained sample in accordance with AASHTO R60			
<b>Procedure</b>			
2. Bowl filled in 2 layers			
3. Each layer rodded 25 times			
4. Bowl tapped (sharply) 10-15 times after rodding each layer			
5. Used funnel, water added, then alcohol added, then final water added until liquid level close to zero			
6. Funnel removed, adjusted the water to where the bottom of the meniscus is on zero			
7. Screw cap attached and tightened			
<b>Initial Reading</b>			
1. Unit inverted and agitated at 5 second intervals for a minimum of 45 seconds and until concrete is free from the base			
2. Unit vigorously rolled $\frac{1}{4}$ to $\frac{1}{2}$ turn forward and back several times with base at a $45^\circ$ angle, then turn base about $\frac{1}{3}$ turn and rolling process resumed			
3. Meter checked for leaks; if leaking, test started over with a new sample			
4. Apparatus placed upright, cap loosened and allowed to stand until air rises to the top <ul style="list-style-type: none"> <li>a. Less than 0.25% change in 2 minutes (without excessive foam), initial reading recorded to the nearest 0.25%</li> <li>b. More than 6 minutes to stabilize or observed excessive foam, test discarded and new test ran</li> </ul>			
<b>Confirmation of Initial Meter Reading</b>			
1. One-minute rolling repeated, and liquid level checked			
2. Confirmation reading is greater than 0.25% of initial, new meter reading recorded as new initial reading, repeat 1-minute rolling			
3. Level of liquid read less than 0.25% change, final meter reading recorded to nearest 0.25%			
4. Apparatus disassembled and checked for undisturbed concrete			
<b>Calculations</b>			
1. Correction factor from Table 1 subtracted for use of 2.5 pints or more of alcohol			
2. If required, number of calibration cups of water added to air content			
3. Air content reported to the nearest 0.25% air			

PASS    PASS

FAIL    FAIL

Examiner: \_\_\_\_\_ Date: \_\_\_\_\_



# APPENDIX





## Standardization of AASHTO T121m Measure

Measure the inside diameter, the inside height, and the minimum thicknesses for the measure, see Table 1 below. Record these measurements in a lab quality manual.

**Table 1**  
**Dimensions of Measures**

Capacity m <sup>3</sup> (ft <sup>3</sup> )	Inside Diameter mm (in.)	Inside Height mm (in.)	Minimum Thicknesses mm (in.)		Nominal Maximum Size of Coarse Aggregate** mm (in.)
			Bottom	Wall	
0.0071 (1/4)*	203 ±2.54 (8.0 ±0.1)	213 ±2.54 (8.4 ±0.1)	5.1 (0.20)	3.0 (0.12)	25 (1)
0.0142 (1/2)	254 ±2.54 (10.0 ±0.1)	279 ±2.54 (11.0 ±0.1)	5.1 (0.20)	3.0 (0.12)	50 (2)
0.0283 (1)	356 ±2.54 (14.0 ±0.1)	284 ±2.54 (11.2 ±0.1)	5.1 (0.20)	3.0 (0.12)	76 (3)

\* *Note:* Measure may be the base of the air meter used in the FOP for AASHTO T 152.

\*\* Nominal maximum size: One sieve larger than the first sieve to retain more than 10 percent of the material using an agency specified set of sieves based on cumulative percent retained. Where large gaps in specification sieves exist, intermediate sieve(s) may be inserted to determine nominal maximum size.

### Standardization of Measure

Standardization is a critical step to ensure accurate test results when using this apparatus. Failure to perform the standardization procedures as described herein will produce inaccurate or unreliable test results.

1. Determine the mass of the dry measure and strike-off plate.
2. Fill the measure with water at a temperature between 16°C and 29°C (60°F and 85°F) and cover with the strike-off plate in such a way as to eliminate bubbles and excess water.
3. Wipe the outside of the measure and cover plate dry, being careful not to lose any water from the measure.
4. Determine the mass of the measure, strike-off plate, and water in the measure.
5. Determine the mass of the water in the measure by subtracting the mass in Step 1 from the mass in Step 4.
6. Measure the temperature of the water and determine its density from Table 2, interpolating as necessary.
7. Calculate the volume of the measure,  $V_m$ , by dividing the mass of the water in the measure by the density of the water at the measured temperature, from Table 2.

$$V_m = \frac{\text{Mass of Water}}{\text{Density of Water}}$$

See **table 2** on the next page

Example: at 23°C (73.4°F)

$$V_m = \frac{7.062 \text{ kg}}{997.54 \text{ kg/m}^3} = 0.007079 \text{ m}^3 \quad V_m = \frac{15.53 \text{ lb}}{62.274 \text{ lb/ft}^3} = 0.2494 \text{ ft}^3$$

**Table 2**

**Unit Mass of Water  
15°C to 30°C**

°C	(°F)	kg/m <sup>3</sup>	(lb/ft <sup>3</sup> )	°C	(°F)	kg/m <sup>3</sup>	(lb/ft <sup>3</sup> )
15	(59.0)	999.10	(62.372)	23	(73.4)	997.54	(62.274)
15.6	(60.0)	999.01	(62.366)	23.9	(75.0)	997.32	(62.261)
16	(60.8)	998.94	(62.361)	24	(75.2)	997.29	(62.259)
17	(62.6)	998.77	(62.350)	25	(77.0)	997.03	(62.243)
18	(64.4)	998.60	(62.340)	26	(78.8)	996.77	(62.227)
18.3	(65.0)	998.54	(62.336)	26.7	(80.0)	996.59	(62.216)
19	(66.2)	998.40	(62.328)	27	(80.6)	996.50	(62.209)
20	(68.0)	998.20	(62.315)	28	(82.4)	996.23	(62.192)
21	(69.8)	997.99	(62.302)	29	(84.2)	995.95	(62.175)
21.1	(70.0)	997.97	(62.301)	29.4	(85.0)	995.83	(62.166)
22	(71.6)	997.77	(62.288)	30	(86.0)	995.65	(62.156)

**Calculation Example: Standardizing a Measure**

$$V_m = \frac{W_{mgw} - W_{mg}}{W_s}$$

$V_m$  = Volume of the measure = \_\_\_\_\_?

$W_{mgw}$  = weight of the plate, glass, and water = 32.78 lbs.

$W_{mg}$  = weight of the measure and glass plate = 17.17 lbs.

$W_s$  = from the chart, density of water at 75 °F  
from the chart = 62.26 lb/ft<sup>3</sup>

Empty measure = 8.08 lbs.

$$V_m = \frac{32.78 \text{ lb.} - 17.17 \text{ lb.}}{62.26 \text{ lb/ft}^3}$$

**Ans:** Volume of the measure = 0.2507 = **0.251 ft<sup>3</sup>**

Report to nearest 0.001 ft<sup>3</sup>

Temperature °F	Pounds Per Cubic Foot
60	62.37
65	62.34
70	62.30
73.4	62.27
75	62.26
80	62.22
85	62.17

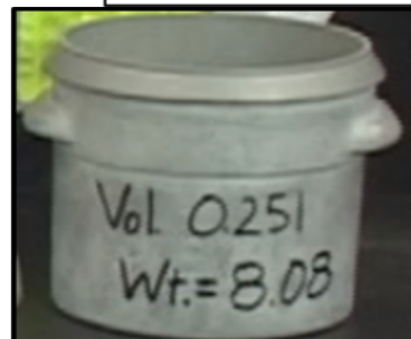



## Apparatus for Air Meter – Volumetric

**Air Meter** – The air meter consists of a bowl and a top section (See Figure 1) conforming to the following requirements:

The bowl and the top sections shall be of sufficient thickness and rigid enough to withstand rough field use. The material shall not be marked by high pH cement paste, deformed from high temperatures or brittle or cracked from low temperatures. The apparatus must have a watertight seal when assembled.

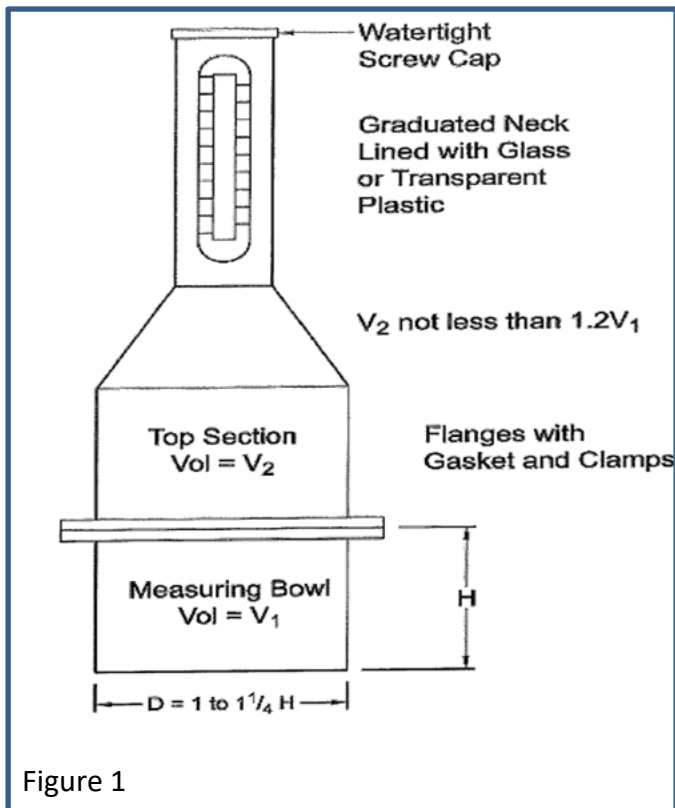

**Bowl**- The bowl diameter is equal to 1 to 1.25 times the height and constructed with a flange at or near the top surface. Bowls shall not have a capacity of less than 2.0 Liters.

**Top Section** – the top shall have a capacity at least 20% larger than the bowl and equipped with a flexible gasket with a device to attach the top section to the bowl to create a water tight connections. The top section shall be have a transparent scale, graduated in increments not greater than 0.5% from zero at the top, to 9% or more of the volume of the bowl. Graduations shall be accurate to  $\pm 0.1\%$  by volume of the bowl. The upper end of the neck shall have a watertight cap that will maintain a seal when the meter is inverted and rolled.

**Funnel** – A funnel with a spout of a size permitting it to be inserted through the neck of the top section and long enough to extend to a point just above the bottom of the top section. The discharge end of the spout shall be constructed so when water is added to the container there will be very little disturbance of the concrete.

**Tamping Rod** – a round, straight steel rod, with a  $16\pm 2$ -mm ( $5/8$  inches  $\pm 1/16$  inch) diameter. The rod length shall be 100mm (4 inches) greater than the depth of the measure in which rodding is being performed but not greater than 600mm (24 inches) in overall length. The length tolerance for the tamping rod shall be  $\pm 4$ mm ( $\pm 1/8$  inch). The rod shall have the tamping end or both ends rounded to a hemispherical tip of the same diameter as the rod.

**NOTE 1** – A rod length of 400mm. (16 inches) to 600mm (24 inches) meets the requirements of the following AASHTO Test Methods: T23, T119M/T 119, T121M/T 121, T152, and T196M/T 196.

**Strike-Off Bar** – A flat, straight steel bar at least 3 by 20 by 300mm (0.125 by 0.75 by 12 inch), or a flat, straight, high-density polyurethane bar, or other plastic of equal or greater abrasion resistance, at least 6 by 20 by 300mm ( $1/4$  by  $3/4$  by 12 inch).

**Calibrated Cup** – A metal or plastic cup either having a capacity of or being graduated in increments equal to  $1.0 \pm 0.04$  percent of the volume of the bowl of the air meter. The calibrated cup is only to be used to add water when the concrete air content exceeds 9% or the calibrated range of the meter.

**Measuring Vessel for Isopropyl Alcohol** – a vessel with a minimum capacity of 500mL (1pt) with graduations not larger than 100ml (4oz) for measuring a quantity of isopropyl alcohol.

**Syringe** – A rubber syringe having a capacity of at least 50mL (2oz).

**Pouring Vessel for Water** – A container of approximately 1L (1qt) capacity.

**Scoop** – Of a size large enough so each amount of concrete obtained from the sampling receptacle is representative and small enough so it is not spilled during placement in the bowl.

**Isopropyl Alcohol** – Use 70% by volume isopropyl alcohol (approximately 65% by mass). Other foam-dispersing agents are permitted if tests demonstrate that the use of the agent does not change the indicated air content, in the amounts being used, by more than 0.1% or if correction factors are developed similar to those in table 1. When other dispensing agents are used, a copy of the records documenting the testing or calculations shall be available in the laboratory.

**Note 2** – Seventy % isopropyl alcohol is commonly available as rubbing alcohol. More concentrated grades can be diluted with water to the required concentration.

**Mallet** – A mallet (with a rubber or rawhide head) with a mass of approximately  $600 \pm 200$ g ( $1.25 \pm 0.5$ lb.).

## Calibration

Calibrate the meter and calibrated cup initially and at three-year intervals or whenever there is reason to suspect damage or deformation of the meter or calibrated cup.

Determine the volume of the bowl, with an accuracy of at least 0.1%, by determining the mass of water required to fill it at room temperature and dividing this weight by the density of water at the same temperature. Follow the calibration procedure outlined in AASHTO T19M/T19.

Determine the accuracy of the graduations on the neck of the top section of the air meter by filling the assembled measuring bowl and top section with water to a preselected air content graduation and then determining the quantity of 21.1°C water required to fill the meter to the zero mark. The quantity of water added shall equal the preselected air content graduation within  $\pm 0.1$  volume percent of the measuring bowl. Repeat the procedure to check a minimum of three graduations within the expected range of use.

Add water in increments of 1.0 percent of the volume of the bowl to check accuracy throughout the graduated range of air content. The error at any point throughout the graduated range shall not exceed 0.1% of air.

Determine the volume of the calibrated cup using water at 21.1°C by the method outlined in Section 5.2., a quick check can be made by adding one or more calibrated cups of water to the assembled apparatus and observing the increase in the height of the water column after filling to a given level.

## Apparatus

**Beam Molds** – beam molds shall be of the shape and dimensions required to produce the specimens that are at least 2 inches greater in length than three times the depth as tested. The ratio of width to depth as molded shall not exceed 1.5. The minimum cross sectional dimension of the beam shall be as stated in Table 2. Unless otherwise specified by MoDOT, the standard beam shall be 6 X 6 inches cross section.

TABLE 2	
TABLE 2 Nominal Maximum Aggregate Size (NMAS)	Minimum Cross-Sectional Dimension
≤1 inch	4 x 4 inches
≤1 inch < NMAS ≤2 inches	6 X6 inches

The inside surfaces of the beam molds shall be smooth. The sides, bottom, and ends shall be at right angles to each other and shall be straight and true and free of warpage. Maximum variation from the nominal cross section shall not exceed 3.2mm (1/8 inch) for molds with depth or breadth of 6 inches or more, or 1/16<sup>th</sup> inch for molds of smaller depth or breadth. Except for flexure specimens, molds shall not vary from the nominal length by more than 1/16<sup>th</sup> inch of the required length. NOTE: Greater lengths are allowed.



**Tamping Rods** – A round, smooth, straight, steel rod with a diameter conforming to the requirements in Table 1. The length of the tamping rod shall be at least 100mm (4inch) greater than the depth of the mold in which rodding is being performed, but not greater than 600mm (24inch) in overall length. The rod shall have the tamping end or both ends rounded to a hemispherical tip of the same diameter as the rod.

**Table 1—Tamping Rod Requirements**

Diameter of Cylinder or Width of Beam, mm (in.)	Rod Dimensions <sup>a</sup>	
	Diameter, mm (in.)	Length of Rod, mm (in.)
<150 (6)	10 ( <sup>3</sup> / <sub>8</sub> )	300 (12)
150 (6)	16 ( <sup>5</sup> / <sub>8</sub> )	500 (20)
225 (9)	16 ( <sup>5</sup> / <sub>8</sub> )	650 (26)

<sup>a</sup> Rod tolerances length  $\pm 100$  mm (4 in.) and diameter  $\pm 2$  mm (<sup>1</sup>/<sub>16</sub> in.).



**Vibrators** – An Internal vibrator shall be used. The vibrator frequency shall be at least 9000 vibrations per minute (150Hz) while the vibrator is operating in the concrete. The diameter of a round vibrator shall be no more than  $\frac{1}{4}$  of the diameter of the cylinder mold or  $\frac{1}{4}$  the width of the beam mold. Other shaped vibrators shall have a perimeter equivalent to the circumference of an appropriate round vibrator. The combined length of the vibrator shaft and vibrating element shall exceed the depth of the section being vibrated by at least 75mm (3inches). The vibrator frequency shall be checked periodically.

**Air content apparatus** – The apparatus for measuring air content shall conform to the requirements of T196M/T196 or T152

**Temperature Measuring Devices** – the temperature measuring devices shall conform to the applicable requirements of MT 20.

4.1-- Air Meters – There are two basic designs Meter Type A and Meter Type B.

4.1.1-- Meter Type A – an air meter consisting of a measuring bowl and cover assembly, see image below:



**Meter Type A**



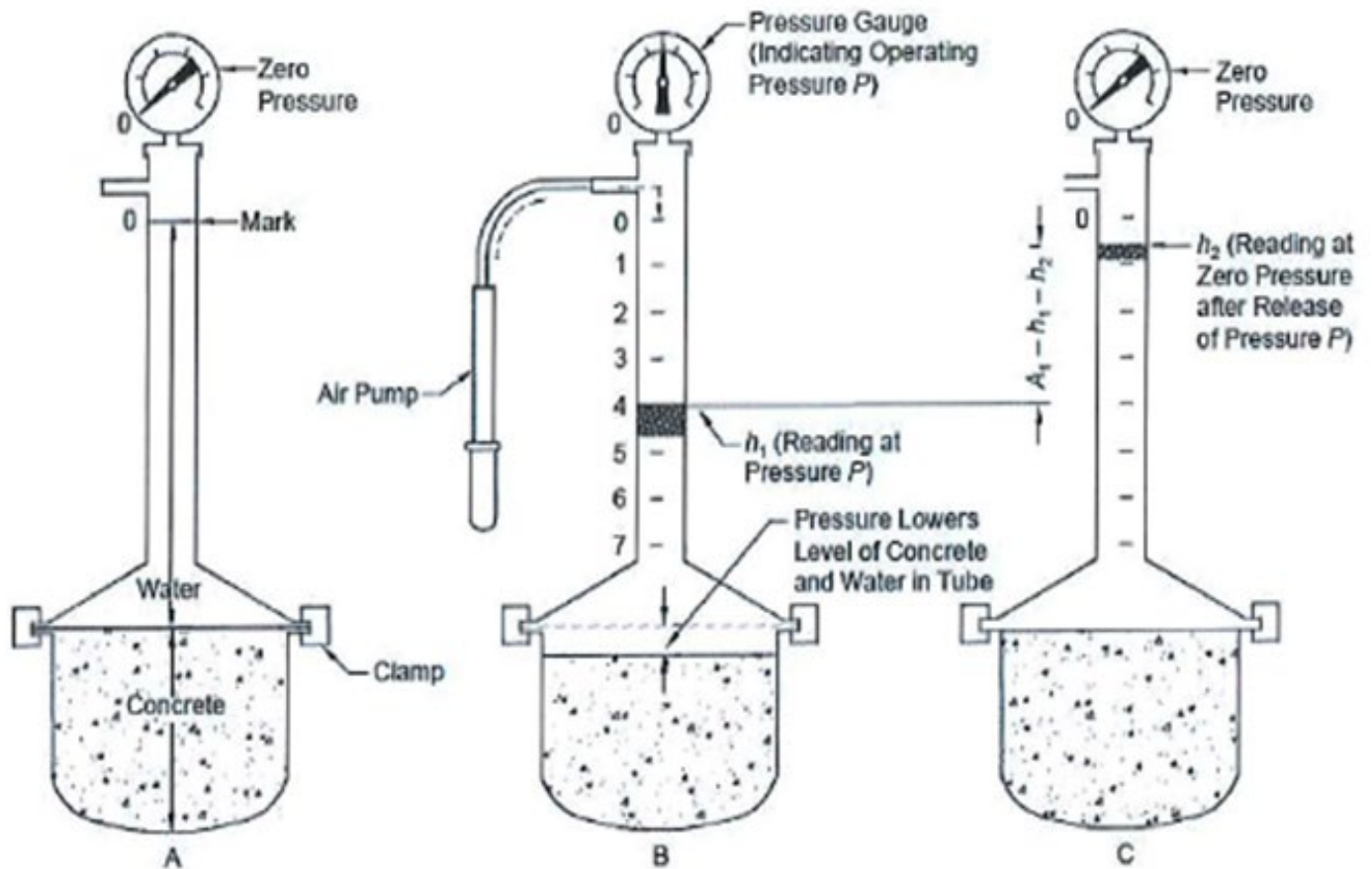

Note:  $A_1 = h_1 - h_2$  when measuring bowl contains concrete as shown in this figure; when measuring bowl contains only aggregate and water,  $h_1 - h_2 = C$  (aggregate correction factor).  
 $A_1 - G = A$  (entrained air content of concrete).

**Figure 1**—Illustration of the Pressure Method for Air Content: Type A Meter

The operational principle of this meter consists of introducing water to a predetermined height above a sample of concrete of known volume and the application of a predetermined air pressure over the water. The determination consists of the reduction in volume of the air in the concrete sample by observing the amount the water level is lowered under the applied pressure, the latter amount being standardized in terms of percent of air in the concrete sample.

**4.1.2-- Meter Type B** – An air meter consisting of a measuring bowl and cover assembly, see image below:



**Meter Type B**

The operational principle of this meter consists of equalizing a known volume of air at a known pressure in a sealed air chamber with the unknown volume of air in the concrete sample, the dial on the pressure gauge being standardized in terms of percent air for the observed pressure in which equalization takes place. Working pressures of 7.5 to 300 psi have been used satisfactorily.

**4.2-- Measuring Bowl** – Must be cylindrical in shape, made of steel, hard metal, or other hard material not readily attacked by the cement paste, having a minimum diameter equal to 0.75 to 1.25 times the height, and a capacity of at



least 0.20 ft<sup>3</sup>. It shall be flanged or otherwise constructed to provide for a pressure-tight fit between the measuring bowl and the cover assembly. The interior surfaces of the measuring bowl and surfaces of rims, flanges, and other component fitted parts shall be machined smooth. The measuring bowl and cover assembly shall be sufficiently rigid to limit the expansion factor, *D*, of the apparatus assembly (**Annex A1.5**) to not more than 0.1% of air content on the indicator scale when under normal operating pressure.

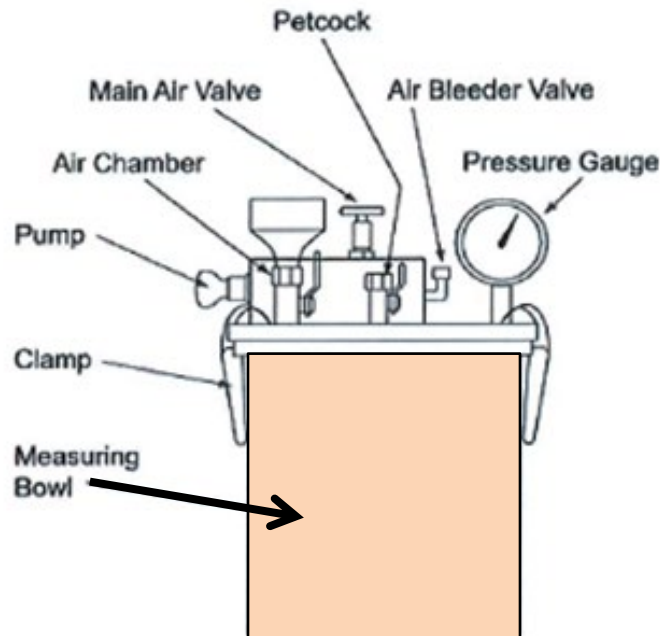

2a. Horizontal Air Chamber

#### 4.3-- Cover Assembly:

**4.3.1--** The cover assembly shall be made of steel, hard metal, or other hard material not readily attacked by the cement paste. It shall be flanged or otherwise constructed to provide for a pressure-tight fit between measuring bowl and cover assembly and shall have machined smooth interior surfaces contoured to provide an air space above the level of the top of the measuring bowl. The cover shall be rigid to limit the expansion factor of the apparatus assembly as prescribed in Section 4.2.

**4.3.2 --**The cover assembly shall be fitted with a means of direct reading of the air content. The cover for the **Type A meter** shall be fitted with a standpipe, which may be a transparent graduated tube or may be a metal tube of uniform bore with a glass water gauge attached. In the **Type B meter**, the dial of the pressure gauge shall be standardized to indicate the percent of air. Graduations shall be provided for a range in air content of at least 8%, easily readable to 0.1%, as determined by the proper air pressure standardization test.

**4.3.3--** The cover assembly shall be fitted with air valves, air bleeder valves, for bleeding off air, and petcocks through which water may be introduced as necessary. The cover shall have a way to clamp or tighten down to the measuring bowl and provide a pressure-tight seal without entrapping air at the joint between the flanges of the cover and the measuring bowl. A suitable hand pump shall be provided with the cover, either as an attachment or as an accessory.

**4.4-- Standardization Vessel** – A measure having an internal volume equal to a percent of the volume of the measuring bowl corresponding to the approximate percent of air in the concrete to be tested; or, if smaller, it shall be possible to check standardization of the meter indicator at the approximate percent of air in the concrete to be tested by repeated filling of the measure. When the design of the meter requires placing the standardization vessel within the measuring bowl to check standardization, the measure shall be cylindrical in shape and of an inside depth  $\frac{1}{2}$  inch less than that of the measuring bowl.

**NOTE:** When design of the meter requires withdrawing of water from the water-filled measuring bowl and cover assembly to check standardization, the measure may be an integral part of the cover assembly or maybe a separate cylindrical measure.

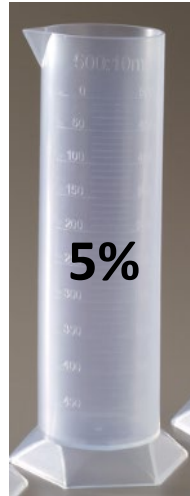

**4.5--** The designs of various available types of air meters are such that they differ in operating techniques and, therefore, all of the items described in sections 4.6 through 4.16 may not be required.

**4.6-- Coil Spring or Other Device – for Holding Standardization Cylinder in Place**

**4.7-- Spray Tube** – a brass tube of appropriate diameter, which may be an integral part of the cover assembly or which may be provided separately. It shall be so constructed that when water is added to the container, it is sprayed to the walls of the cover in such a manner as to flow down the sides causing a minimum of disturbance to the concrete.

**4.8 --Trowel** – A standard brick mason’s trowel

**4.9-- Tamping Rod** – A round, straight steel rod, with a  $\frac{5}{8}$  inch  $\pm$  1/16 inch diameter, the length shall be at least 4 inches greater than the depth of the measure in which rodding is being performed but not greater than 24 inches in overall length. The length tolerance for the tamping rod is  $\pm$   $\frac{1}{8}$  inch. The rod shall have the tamping end or both ends rounded to a hemispherical tip of the same diameter as the rod.

**4.10-- Mallet** – a mallet (with a rubber or rawhide head) weighing approximately  $1.25 \pm 0.50$  pounds for use with measures of  $0.5 \text{ ft}^3$  or smaller and a mallet weighting approximately  $2.25 \pm 0.50$  pounds for use with measures larger than  $0.5 \text{ ft}^3$ .

**4.11-- Strike-Off Bar** – a flat straight bar of steel or other suitable metal at least  $\frac{1}{8}$  inch thick and  $\frac{1}{4}$  inch wide by 12 inches long.

**4.12-- Strike-Off Plate** – A flat rectangular metal plate at least ¼ inch thick or a glass or acrylic plate at least ½ inch thick with a length and width at least 2 inches greater than the diameter of the measure with which it is to be used. The edges of the plate shall be straight and smooth within a tolerance of 1/16 inch.

**4.13-- Funnel** – With the spout fitting into a spray tube.

**4.14-- Measure for Water** – Having the necessary capacity to fill the indicator with water from the top of the concrete to the zero mark.

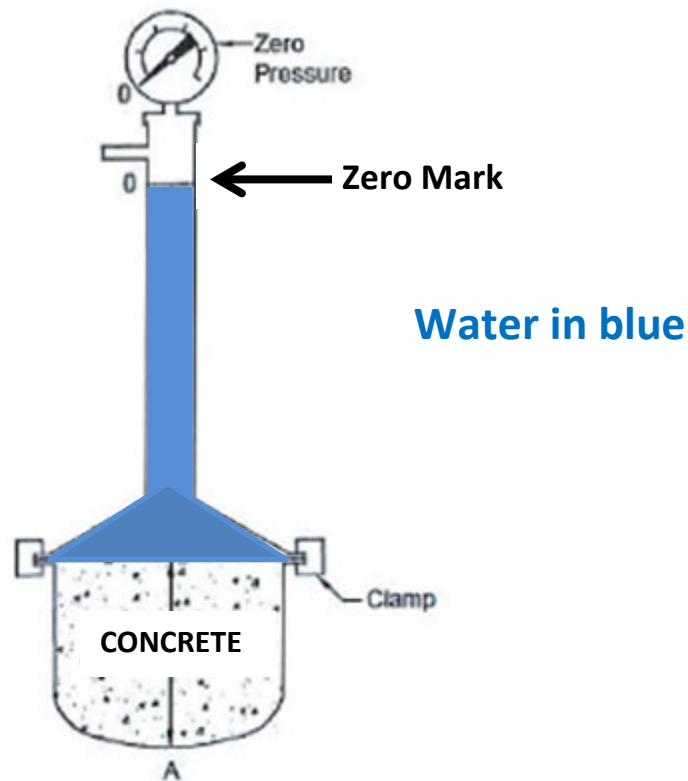

**4.15 -- Vibrator** – as described in R39.

### » *Internal Vibrator*

- $\geq 9000$  rpm
- Element  $\frac{3}{4}$ " -  $1\frac{1}{2}$ " dia.
- Length of shaft and element must exceed depth of section by  $\geq 3$ "



**4.16 – Sieves** -  $1\frac{1}{2}$  inch with not less than 2 ft<sup>2</sup> of sieving area.

**4.17 – Scoop** – Of a size large enough so each amount of concrete obtained from the sampling receptacle is representative and small enough so it is not spilled during placement in the measuring bowl.

## **6-- Standardization of a Type A Meter**

**6.1** Make standardization tests in accordance with procedures prescribed in the annex. Rough handling will affect the standardization of Type A meters. Changes in barometric pressure will also affect the standardizations of Type A meters.

The steps described in **Sections A1.2 to A1.6**, as applicable to the meter type under consideration, are prerequisites for the final standardization test to determine the operating pressure, P, on the pressure gauge of the Type ammeter as described in **Section A1.7**. Normally the steps in **Sections A1.2 to A1.6** need be made only once (at the time of initial standardization) or only occasionally to check volume constancy of the standardization cylinder and measuring bowl. On the other hand the standardization test described in **Sections A1.8 and A1.9**, as applicable to the meter type being standardized, must be made as frequently as necessary to ensure that the proper gauge pressure, P is being used for the Type A meter. A change in elevation of more than 600 feet from location at which a Type A meter was last standardized will require re-standardization in accordance with **Section A1.8**.

## 7.4-- Aggregate Correction Factor Determination for Type A meters

**7.4.1 – Initial Procedure for Type A Meter** – When all of the aggregate has been placed in the measuring bowl (see slide show for 7.3 for placement of Aggregate in the Measuring Bowl), remove excess foam and keep the aggregate inundated for a period of time approximately equal to the time between introduction of the water into the mixer and the time of performing the test for air content before proceeding with the determination as directed in section 7.4.2 or 7.4.3

**7.4.2 – Type A Meter** – Complete the test as described in section 8.1 through 9.3.2. The aggregate correction factor,  $G$ , is equal to  $h_1 - h_2$ . (See figure 1) The aggregate correction factor will vary with different aggregates. It can be determined only by test, because apparently is not directly related to absorption of the particles. The test can be easily made and should not be ignored. Ordinarily the factor will remain reasonable constant for given aggregates, but an occasional check test is recommended.

## 9.3 – Procedure for Determining Air Content of Concrete– Type A Meter

**Preparation for Test** – NOTE: See section 9 on the slide show for placement of, and consolidation by Rodding or Vibrating the concrete sample.

Thoroughly clean the flanges or rims of the measuring bowl and of the cover assembly so that when the cover is clamped in place a pressure-tight seal will be obtained. Assemble the apparatus and add water over the concrete by means of the tube until it rises to about the halfway mark in the standpipe. Incline the apparatus assembly about 30 degrees from vertical and, using the bottom of the measuring bowl as a pivot, describe several complete circles with the upper end of the column, simultaneously tapping the cover lightly to remove any entrapped air bubbles above the concrete sample. Return the apparatus assembly to a vertical position and fill the water column slightly above the zero mark, while lightly tapping the side of the measuring bowl. Bring the water level to the zero mark of the graduated tube before closing the vent at the top of the water column.

**9.3.3—Test Procedure** – Apply slightly more than the desired test pressure,  $P$  (about 0.2psi), to the concrete by means of the small hand pump. To relieve local restraints, tap the sides of the measure sharply and, when the pressure gauge indicates the exact test pressure,  $P$ , as determined in accordance with Section A1.7, read the water level,  $h_1$ , and record to the nearest division or half-division on the graduated precision-bore tube or gauge glass of the standpipe. See figure 1B, for extremely harsh mixes, it may e necessary to tap the measuring bowl vigorously until further tapping procedures no change in the indicated air content. Gradually release the air pressure through the vent at the top of the water column and tap the sides of the measuring bowl lightly for about 1 minute record the water level,  $h_2$ , to the nearest division or half-division.

See figure 1C, calculate the apparent air content as follows:

$$A1 = h1 - h2$$

Where:

A1 = apparent air content

h1 = water level reading at pressure, P

h2 = water level reading at zero pressure after release of pressure, P

**9.3.4-- Check Test** – Repeat the steps described in section 9.3.3 without adding water to reestablish the water level at the zero mark. The two consecutive determinations of apparent air content should check within 0.2 percent of air and shall be averaged to give the value A1 to be used in calculating the air content, As, in accordance with Section 10.

**9.3.5**—In the event the air content exceeds the range of the meter when it is operated at the normal test pressure P, reduce the test pressure to the alternative test pressure P1 and repeat the steps outlined in sections 9.3.3 and 9.3.4.

$$P1 = Pa p / (2Pa - P)$$

Where:

P1 = alternative test pressure, psi

Pa = atmospheric pressure, psi (approximately 14.7psi but will vary with altitude and weather conditions);

P = normal test or operating gauge pressure, psi

## Apparatus

**Molds, General** – Molds for specimens or fastenings in contact with the concrete shall be made of steel, cast iron, or other nonabsorbent material, nonreactive with concrete containing portland or other hydraulic cements. Molds shall hold their dimensions and shape under conditions of use. Provisions for tests of watertightness are given in M205M/M205. A suitable sealant, such as heavy greases, modeling clay or microcrystalline wax shall be used where necessary to prevent leakage through the joints. Positive means shall be provided to hold base plates firmly to the molds. Reusable molds shall be lightly coated with mineral oil or a suitable nonreactive form release material before use.

**Cylinder** – Molds for casting concrete test specimens shall conform to the requirements of M205M/M 205.



**Beam Molds** – beam molds shall be of the shape and dimensions required to produce the specimens stipulated in section in ~~T23~~ **R100**. The inside surfaces of the molds shall be smooth. The sides, bottom, and ends shall be at right angles to each other and shall be straight and true and free of warpage. Maximum variation from the nominal cross section shall not exceed 3.2mm (1/8 inch) shorter than the required length in accordance with section 6.2 in AASHTO T23.





**Tamping Rods** – A round, smooth, straight, steel rod with a diameter conforming to the requirements in Table 1. The length of the tamping rod shall be at least 100mm (4inch) greater than the depth of the mold in which rodding is being performed, but not greater than 600mm (24inch) in overall length. The rod shall have the tamping end or both ends rounded to a hemispherical tip of the same diameter as the rod.



**Table 1**—Tamping Rod Requirements

Diameter of Cylinder or Width of Beam, mm (in.)	Rod Dimensions <sup>a</sup>	
	Diameter, mm (in.)	Length of Rod, mm (in.)
<150 (6)	10 (3/8)	300 (12)
150 (6)	16 (5/8)	500 (20)
225 (9)	16 (5/8)	300 (24)

<sup>a</sup> Rod tolerances length  $\pm 100$  mm (4 in.) and diameter  $\pm 2$  mm (1/16 in.).



**Vibrators** – An internal vibrator shall be used. The vibrator frequency shall be at least 9000 vibrations per minute (150Hz) while the vibrator is operating in the concrete. The diameter of a round vibrator shall be no more than 1/4 of the diameter of the cylinder mold or 1/4 the width of the beam mold. Other shaped vibrators shall have a perimeter equivalent to the circumference of an appropriate round vibrator. The combined length of the vibrator shaft and vibrating element shall exceed the depth of the section being vibrated by at least 75mm (3inches). The vibrator frequency shall be checked periodically.

**Air content apparatus** – The apparatus for measuring air content shall conform to the requirements of T196M/T196 or T152.

**Temperature Measuring Devices** – The temperature measuring devices shall conform to the applicable requirements of MT 20.



# Glossary

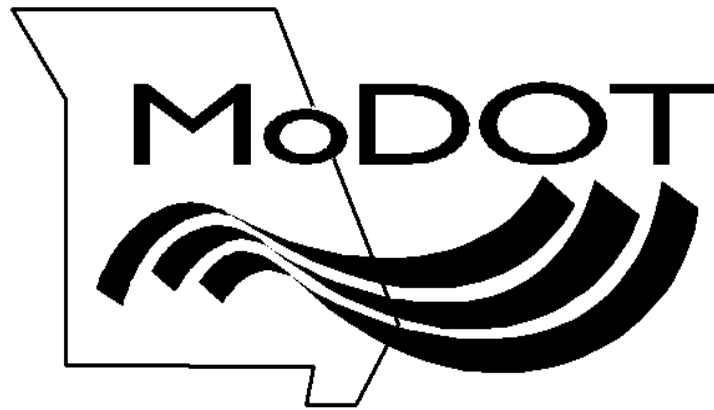



## Glossary of Terms

### **AASHTO**

American Association of State Highway and Transportation Officials

### **Absolute Volume (V)**

The absolute volume of each ingredient in cubic yards is equal to the quotient of the mass of the ingredient divided by the product of its specific gravity times 62.4. The absolute volume of each ingredient in cubic meters is equal to the mass of the ingredient in kilograms divided by 1000 times its specific gravity.

### **Aggregate Correction Factor**

An easily run test that accounts for air in the aggregate structure which fills with water under pressure. It is determined on inundated fine and coarse aggregate in approximately the same moisture condition, amount and proportions occurring in the concrete sample under test.

### **Air Content**

The amount of air in mortar or concrete, exclusive of pore space in the aggregate particles, usually expressed as a percentage of total volume of mortar or concrete.

### **Air Void**

A space in cement paste, mortar, or concrete filled with air, and entrapped air void is characteristically 1mm (0.04 in.) or more in size and irregular in shape; an air entrained air void is typically between 10µm and 1mm in diameter and spherical (or nearly so).

### **Batch Weights**

Quantity of concrete or mortar mixed at one time.

### **Bulk Specific Gravity and Mass**

For the aggregate components, the bulk specific gravity and mass should be based on the saturated surface-dry condition. For cement, the actual specific gravity should be determined by T133. A value of 3.15 may be used for cements manufactured to meet the requirements of M85.

### **Central Mixed Concrete**

A stationary concrete mixer from which the fresh concrete is transported to the work.

### **Compression Test**

Test made on a specimen of mortar or concrete to determine the compressive strength; unless otherwise specified, compression tests of mortars are made on 50mm (2 in.) cubes, and compression tests of concrete are made on cylinders either 4 inches in diameter and 8 inches in height or 6 inches in diameter and 12 inches in height.

**Compressive Strength**

The measure resistance of a concrete or mortar specimen to axial loading; expressed as pounds per square inch (psi) of cross-sectional area.

**Concrete**

A composite material that consists essentially of a binding medium in which is embedded particles or fragments of relatively inert material filler. In Portland cement concrete, the binder is a mixture of Portland cement and water; the filler may be any of a wide variety of natural or artificial aggregates.

**Consistency**

The relative mobility or ability of fresh concrete or mortar to flow. The usual measures of consistency are slump or ball penetration for concrete and flow for mortar.

**Consolidation**

The process of inducing a closer arrangement of the solid particles in freshly mixed concrete or mortar during placement by the reduction of voids, usually by vibration, centrifugation, tamping, or some combination of these actions; also applicable to similar manipulation of other cementitious mixtures, soils, aggregates, or the like.

**Core**

A cylindrical specimen of standard diameter drilled from a structure or rock foundation to be bested compression or examined petrographically.

**Entrained Air**

Round, uniformly distributed, microscopic, non-coalescing air bubbles entrained by the use of air-entraining agents; usually less than 1mm (.04 in.) in size.

**Entrapped Air**

Air in concrete that is not purposely entrained. Entrapped air is generally considered to be large voids (larger than 1mm [.04 in.]).

**Field Cured Cylinders**

Test cylinders cured as nearly as practicable in the same manner as the concrete in the structure to indicate when supporting forms may be removed, additional loads may be imposed, or the structure may be placed in service.

**Finishing**

Leveling, smoothing, compacting, and otherwise treating surfaces of fresh or recently placed concrete or mortar to produce desired appearance and service.

**Gradation**

The distribution of particles of granular material among various sizes, usually expressed in terms of cumulative percentages larger or smaller than each of a series of sizes (sieve openings) or the percentages between certain ranges of sizes (sieve openings).

**Length Measurement**

The longitudinal measurement taken along the specimen axis

**Plasticity**

The property of fresh concrete or mortar which determines its resistance to deformation or its ease of molding.

**PSI**

Pounds per square inch; a measurement of the compressive, tensile or flexural strength of concrete as determined by appropriate test.

**Pumping**

The forceful displacement of a mixture of soil and water that occurs under slab joints, cracks, cracks and pavement edges which are depressed and released quickly by high-speed heavy vehicle loads; occurs when concrete pavements are placed directly on fine-grained, plastic soils or erodible sub base materials.

**Quality Assurance**

Planned and systematic actions by an owner or his representative to provide confidence that a product or facility meet applicable standards of good practice. This involves continued evaluation of design, plan specification development, contract advertisement and award, construction, and maintenance, and the interactions of these activities.

**Quality Control**

Actions taken by a producer or contractor to provide control over what is being done and what is being provided so that the applicable standards of good practice for the work are followed.

**Rebar**

Abbreviation for "Reinforcing Bar." Bars, wires, strands, and other slender members embedded in concrete in such a manner that the reinforcement and the concrete act together in resisting forces.

**Rod, Tamping**

A straight steel rod of circular cross section having one or both ends rounded to a hemispherical tip.

**Rodding**

Compaction of concrete by means of a tamping rod

**Sample**

A group of units, or portion of material, taken from a larger collection of units or quantity of material, which serves to provide information that can be used as a basis for action on the larger quantity or the production process; the term is also used in the sense of a sample of observations.

**Slump**

A measure of consistency of freshly mixed concrete, equal to the subsidence measured to the nearest 6mm ( $\frac{1}{4}$  in.) of the molded specimen immediately after removal of the slump cone.

**Standard Cure**

The curing method used when specimens are intended for acceptance testing for specified strength, checking the adequacy of mixture proportions for strength, quality control.

**Strike off**

To remove concrete in excess of that required to fill the form evenly or bring the surface to grade; performed with a straight edged piece of wood or metal by means of forward sawing movement or by a power operated tool appropriate for this purpose; also the name applied to the tool.

**Tamping**

The operation of compacting freshly placed concrete by repeated blows or penetrations with a tamping device.

**Thickness Measurement**

The length measurement of a core taken perpendicular to the driving surface of a pavement.

**Three Point Caliper**

A device used to determine the length of a cylindrical shaped specimen consisting of three resting points and a means of evenly measuring nine different points on the opposite end.

**Total Mass (M)**

The total mass of all materials batched is the sum of the masses of the cement, the fine aggregate in the condition used, the coarse aggregate in the condition used, the mixing water added to the batch, and any other solid or liquid materials used.

**Truck-Mixed Concrete**

Concrete, the mixing of which is accomplished in a truck mixer

**Volumetric Method**

Air is removed from a known volume of concrete by agitation in an excess of water. It may be used with any type of aggregate including light weight and porous material. The test is not affected by atmospheric pressure and the specific gravity of the material need not be known.