

2024 - 2025 Edition

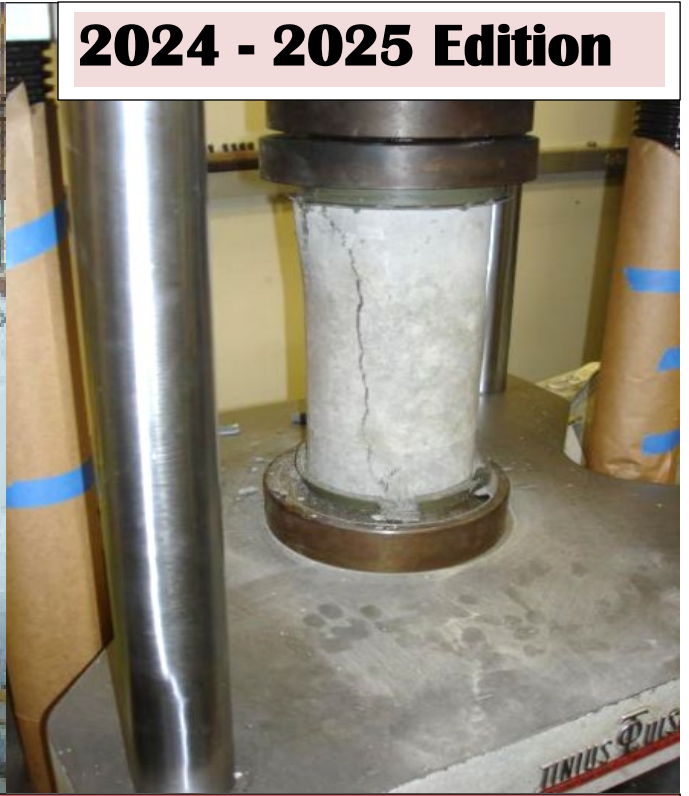

CONCRETE STRENGTH



Course Content

Concrete Strength

| | | |
|----------------------|--------|--|
| AASHTO ASTM C42 | T 24 | Obtaining and Testing Drilled Cores and Sawed Beams of Concrete |
| AASHTO | T 148 | Measuring Length of Drilled Concrete Cores |
| AASHTO ASTM C617 | T 231 | Capping Cylindrical Concrete Specimens |
| ASTM | C 1231 | Use of Unbonded Caps in Determination of Compressive Strength of Hardened Cylindrical Concrete Specimens |
| AASHTO ASTM C39 | T 22 | Compressive Strength of Cylindrical Concrete Test Specimens |
| AASHTO ASTM C78 | T 97 | Flexural Strength of Concrete (Using Simple Beam with Third-Point Loading) |
| APPENDIX GLOSSARY | | |

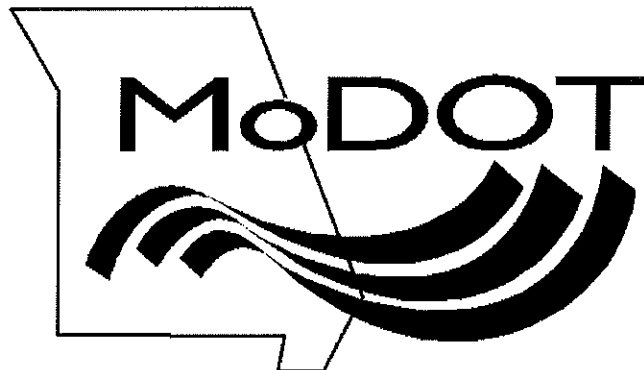

Concrete Strength

2025 No Updates

2024 Updates

- **Updates for AASHTO T231** – added new slides with pictures checking specimens.
- **Updates for AASHTO T22** – Density calculations, Perpendicularity – how to measure, extra problem for diameter, and compressive strength, verification of alignment.
- **Updates for AASHTO T97**
 - Updated 0.38 to 0.40mm for leaf-type feeler gauge, Method change.

2023 Updates

- **Updates for T24 – Obtaining and Drilling Cores and Sawed Beams**
 - (2.2-2.3) M339M/M339, Thermometers Used in the Testing of Construction Materials.
 - E1, Standard Specification for ASTM Liquid-in-Glass Thermometers
 - E230/E230M, Standard Specification for Temperature-Electromotive Force (emf) Tables for Standardized Thermocouples
 - ASTM E2877, Standard Guide for Digital Contact Thermometers
 - IEC 60584-1:2013 Thermocouples – Part 1: EMF Specifications and Tolerances
 - (7.7) Measurement – Measure the length and diameter of the core.
 - (9.2) The thermometer for measuring the temperature of the water shall meet the requirements of M339M/M339 with a temperature range of at least 19 to 27°C (66.4 to 80.6°F) and an accuracy of $\pm 0.5^{\circ}\text{C}$ ($\pm 0.9^{\circ}\text{F}$) (see Note 17)
 - NOTE 17: Thermometer types suitable for use include ASTM E1 mercury thermometers; ASTM E2877 digital metal stem thermometer; ASTM E230/E230M thermocouple thermometer, Type T, Special; or IEC 60584 thermocouple thermometer, Type T, Class 1.
- **Updates for T148 – Measuring Length of Cores**
 - (4.1) This test method requires that at least one end of the core be a finished or formed surface.
 - (6.1) Cores used as specimens for length measurement shall be obtained in accordance with T24M/T24 and be in every way representative of the concrete in the structure from which they are removed.
- **Updates for T22 – Testing Strength**

Table 1—Maximum Diameter of Bearing Face

| Diameter of Test Specimens, mm (in.) | Max Diameter of Round Bearing Face, mm (in.) | Max Dimensions of Square Bearing Face, mm (in.) |
|--------------------------------------|--|---|
| 50 (2) | 105 (4) | 105 by 105 (4 by 4) |
| 75 (3) | 130 (5) | 130 by 130 (5 by 5) |
| 100 (4) | 165 (6.5) | 165 by 165 (6.5 by 6.5) |
| 150 (6) | 255 (10) | 255 by 255 (10 by 10) |
| 200 (8) | 280 (11) | 280 by 280 (11 by 11) |

- (7.4) The thermometer for measuring the temperature of the water shall meet the requirements of M339M/M339 with a temperature range of at least 19 to 27°C (66.4 to 80.6°F) and an accuracy of ±0.5°C (±0.9°F) (see Note 11)
 - NOTE 11: Thermometer types suitable for use include ASTM E1 mercury thermometers; ASTM E2877 digital metal stem thermometer; ASTM E230/E230M thermocouple thermometer, Type T, Special; or IEC 60584 thermocouple thermometer, Type T, Class 1.
- (8.3.1) Unless otherwise specified by the specifier of tests, for this method, the test age shall start at the beginning of casting specimens.
- (9) CALCULATION

9.1. Calculate the compressive strength of the specimen as follows:

SI Units:

Inch-Pound Units:

$$f_{cm} = \frac{4000P_{\max}}{\pi D^2}$$

$$f_{cm} = \frac{4P_{\max}}{\pi D^2}$$

where:

f_{cm} = compressive strength, MPa (psi);

P_{\max} = maximum load, kN (lbf); and

D = average measured diameter, mm (in.).

NOTE: Use at least five digits for the value of π , that is, use 3.1416 or a more precise value.

(9.3) If required, calculate the density of the specimen to the nearest 10kg/m³ (1lb/ft³) using the applicable method.

9.3. If required, calculate the density of the specimen to the nearest 10 kg/m³ (1 lb/ft³) using the applicable method.

9.3.1. If the specimen density is determined based on specimen dimensions, calculate specimen density as follows:

SI Units:

Inch-Pound Units:

$$\rho = \frac{4 \times 10^9 \times W}{\pi \times D^2 \times L} \qquad \rho = \frac{6912 \times W}{\pi \times D^2 \times L} \qquad (4)$$

where:

ρ = specimen density, kg/m³ (lb/ft³);

W = mass of specimen, kg (lb);

D = average measured diameter, mm (in.); and

L = average measured length, mm (in.).

Rectangular Snip

9.3.2. If the specimen density is determined based on submerged weighing, calculate the density as follows:

$$\rho = \frac{w \times \gamma_w}{w - w_s} \qquad (5)$$

where:

ρ = specimen density, kg/m³ (lb/ft³);

w = mass of specimen, kg (lb);

γ_w = density of water at 23°C (73.5°F) = 997.5 kg/m³ (62.27 lb/ft³); and

w_s = apparent mass of submerged specimen, kg (lb).

- (10) REPORT
 - Specimen identification
 - Serial number of delivery ticket, if available.
- (10.1.7) If the average of two or more companion cylinders tested at the same age is reported, calculate the average compressive strength using the unrounded individual compressive strength values. Report the average compressive strength rounded to the nearest 0.1 Mpa (10psi);
- (Figure 2) – Sketches of Types of Fracture

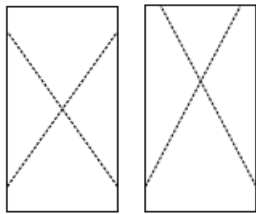

Type 1

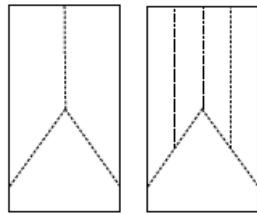

Type 2

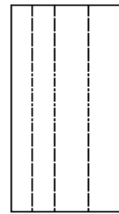

Type 3

Type 1—Reasonably well-formed cones on both ends, less than 25mm (1 in.) of cracking through caps.

Type 2—Well-formed cone on one end, vertical cracks running through caps, no well-defined cone on other end.

Type 3—Columnar vertical cracking through both ends, no well-formed cones.

Type 4—Diagonal fracture with no cracking through ends; tap with hammer to distinguish from Type 1

Type 5—Side fractures at top or bottom; commonly occurs with unbonded caps.

Type 6—Similar to Type 5 but end of cylinder is pointed.

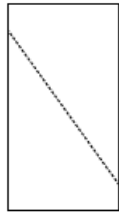

Type 4

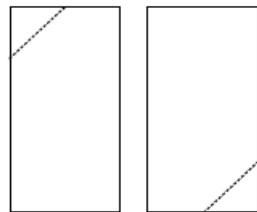

Type 5



Type 6

Updates for T97 – Beams

- (5) APPARATUS:

- 5.2.3.1. The loading blocks and support blocks should not be more than 65 mm (2½ in.) high, measured from the center or the axis of pivot, and should extend entirely across or beyond the full width of the specimen. Each case-hardened bearing surface in contact with the specimen shall not depart from a plane by more than 0.05 mm (0.002 in.) and should be a portion of a cylinder, the axis of which is coincidental with either the axis of the rod or center of the ball, whichever the block is pivoted upon. The angle subtended by the curved surface of each block should be at least 45 degrees (0.80 rad). At least every six months or as specified by the manufacturer of the flexural testing apparatus, clean and lubricate metal-to-metal contact surfaces, such as internal concave surfaces and steel balls and rods of the loading blocks and support blocks. The lubricant shall be a petroleum-type oil, such as conventional motor oil, or as specified by the manufacturer of the apparatus. The support blocks shall be free to rotate.
- 5.2.3.2. The loading blocks and support blocks shall be maintained in a vertical position and in contact with the rod or ball by means of spring-loaded screws that hold them in contact with the rod or ball.
- 5.2.3.3. The uppermost bearing plate and center point ball in Figure 1 may be omitted if the testing machine has a spherically seated bearing block that meets the requirements of T 22M/T 22, provided one rod and one ball are used as pivots for the upper loading blocks.

5. APPARATUS

- 5.1. *Testing Machine*—Hand-operated testing machines having pumps that do not provide a continuous loading in one stroke are not permitted. Motorized pumps or hand-operated positive displacement pumps having sufficient volume in one continuous stroke to complete a test without requiring replenishment are permitted and shall be capable of applying loads at a uniform rate without shock or interruption. The testing machine shall be equipped with a means of recording or holding the peak value that will indicate the maximum load, to within 1 percent accuracy, applied to the specimen during a test.
- 5.1.1. The testing machine shall conform to the requirements of sections on Basis of Verifications, Corrections, and Time Interval between Verification of ASTM E4.
- 5.1.2. Verify the accuracy of the testing machine in accordance with ASTM E4, except that the verified loading range shall be as required for flexural testing. Verification is required:
- 5.1.2.1. Within 13 months of the last verification;
- 5.1.2.2. On original installation; * Rectangular Snip
- 5.1.2.3. After relocation;
- 5.1.2.4. After making repairs or adjustments that affect the operation of the force applying system or the values displayed on the load indicator, except for zero adjustments that compensate for the weight of loading or support blocks or specimen, or both; or
- 5.1.2.5. Whenever there is reason to suspect the accuracy of the indicated forces.
- 5.2. *Loading Apparatus*—The third-point loading method shall be used to determine the flexural strength of concrete. The loading blocks and support blocks shall be designed so that forces applied to the beam will be along lines perpendicular to the side faces of the beam and applied without eccentricity. A diagram of an apparatus that accomplishes this purpose is shown in Figure 1.

2021-2022 Updates

- **Update for T22** for the bearing blocks, location: Appendix for AASHTO T22
The bottom bearing block is specified for the purpose of providing a readily machineable surface for maintenance of the specified surface conditions (note 4). The top and bottom surfaces shall be parallel to each other. Its least horizontal dimension shall be at least 3 percent greater than the diameter of the specimen to be tested. Concentric circles, as described in section 5.2, are optional on the bottom block. **NEW: (If required, the bottom bearing block may be fully supported by spacer blocks. Spacer blocks shall be made of solid steel with parallel top and bottom faces. One vertical center hole up to 19mm (0.75 in.) in diameter is permissible. Spacer blocks shall not be in direct contact with the specimen or the retainers for unbounded caps.)**
- **Update for T22** under Load Indication, location: Appendix for AASHTO T22:
Note 9: Readability is 0.5mm (0.02 in.) along the arc described by the end of the pointer. Also, one half of the scale interval is about as close as can reasonably be read when the spacing on the load-indicating mechanism is between 1mm (0.04 inch) and 2mm (**0.08 inch**). When the spacing is between 2mm and 3mm, one-third of a scale interval can be read with reasonable certainty. When the spacing is 3mm or more, on fourth of a scale interval can be read with reasonable certainty. **Update for T22 Table 2** Permissible Time Tolerances, location: Currently Slide 23 They deleted the percentages and added the note below the table: For test ages not listed, the test age tolerance is ± 2.0 percent of the specified age.

AASHTO T 24

Obtaining and Testing Drilled Cores and Sawed Beams of Concrete

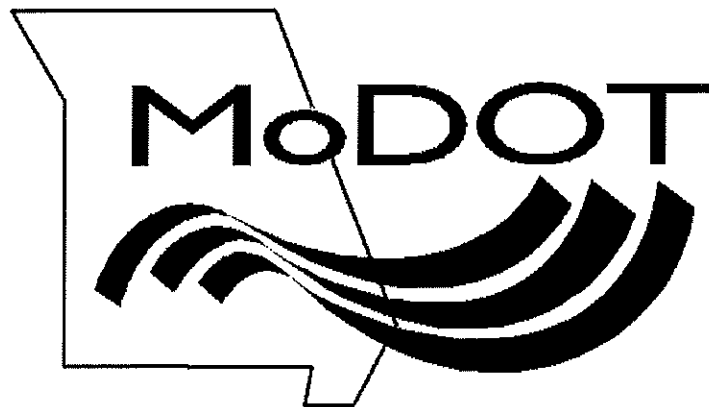

Required Audits

All testers on Federal-Aid Projects (MoDOT or Off-System) are required by the FHWA to be audited at least once per year.

Reasons:

- To ensure proper test procedures are being utilized.
- To ensure testing equipment is calibrated and operating properly.
- **Types of Audits;** procedure or comparison.
- **Be Proactive;** schedule your audit as early as possible with MoDOT Materials in district offices, do NOT wait until the end of the year.
- **Provide Proof;** when audited, present a MoDOT Certification Card, image, or a MoDOT Letter to IAS auditor.

1

AASHTO T 24

Obtaining and Testing Drilled Cores and Sawn Beams of Concrete



Rev 04/04/2023

2

SCOPE

This standard method covers obtaining, preparing, and testing cores drilled from concrete for length or compressive strength. This method also covers sawed beams of concrete.

Note: Cores for Splitting Tensile Strength, will not be covered in this certification. Information on this topic can be found in the Appendix.

3

3

SIGNIFICANCE AND USE

This test method provides standardized procedures for obtaining and testing specimens to determine the flexural strength of concrete.

Sampling and sample preparation requirements are given to ensure that dimensional requirements are met and that the specimens are made of intact, sound concrete, and are as free of flaws as the particular structure will allow.

4

4



The acceptance criteria for core strength is to be established by the specifying authority which is MoDOT.

MoDOT is responsible for the analysis or review and acceptance of the core test results.

Significance and Use

5

5

It is up to **MoDOT** if testing cores with embedded metal or other fibers is allowed, even if the specimen does not meet AASHTO T 24.



When obtaining cores for purposes other than to determine strength, follow instructions provided by MoDOT.

6

6

EQUIPMENT

- Core Drill
- Thermometer
- Maturity Meter
- Plastic Bags
- Concrete Chop Saw
- Triangle
- Ruler
- Calipers
- Scale to 0.01lb
- See the appendix for more information.



7

7

QA CORES



- Quality Assurance (QA) cores will be extracted by the contractor and provided to the Quality Assurance Inspector for evaluation.
- The QA inspector should maintain possession of the QA cores from the time of extraction until they are tested.

8

8

MoDOT EPG - SAMPLING CORES



Cores shall not be taken until the concrete has reached a compressive strength of **3,000 psi**.

EPG 502.2.4.1

The location of Quality Control and Quality Assurance cores shall be determined using random sampling procedure **ASTM D3665** in accordance with this method; AASHTO T 24.

9

9

RANDOM SAMPLES – ASTM D3665

Sample locations are determined using random sampling procedures in accordance with ASTM D 3665.

QC core locations are determined by the engineer.



10

10

Random Sample Location Worksheet

CORE LOCATIONS

Enlarged

PROJECT _____ ROUTE _____ MIX NO. _____
 LOT NO. _____ DATE _____ TECHNICIAN _____
 SUBLot _____
 BEGINNING STATION "STA" _____
 ENDING STATION _____
 LENGTH OF SUBLot "L" _____
 WIDTH OF LANE _____

| RANDOM NUMBERS | | | |
|----------------|--------|--------|--------|
| SUBLot | SUBLot | SUBLot | SUBLot |
| SET A | | | |
| SET B | | | |

| LONGITUDINAL LOCATION | | | | |
|-----------------------|---|---|-----------|---------|
| SUBLot | L | A | X = L + A | STA + X |
| | | | | |
| | | | | |
| | | | | |

| TRANSVERSE LOCATION | | | | | |
|---------------------|-------|---|----------------|-------|--------------------|
| SUBLot | WIDTH | B | W = WIDTH - 2' | W x B | OFFSET = 1 + W x B |
| | | | | | |
| | | | | | |
| | | | | | |

*ALWAYS MEASURE OFFSET FROM RIGHTHAND EDGE
 *STAY APPROXIMATELY 1' FOOT FROM LONGITUDINAL AND TRANSVERSE JOINTS

11

Sampling

11

Example Problem

Length = 1988ft Width = 28ft Depth = 12in.

LOT 3

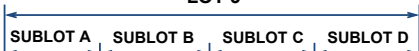

1050+00 1054+97 1059+94 1064+91 1069+88

Area = 1988 * 28 = 55664 sq. ft.
 or 6184.9 sq. yds.

Right Edge of Pavement

12

Sampling

12

Random Sample Location

From Random Number Table
Or
Computer Generated random numbers.

CORE LOCATIONS *Enlarged*

PROJECT: 017725 ROUTE: 26 MIX NO. 11
 LOT NO. DATE TECHNICIAN 11/12/10

SUBLOT
 BEGINNING STATION "STA" 1050+00 1054+97 1059+94 1064+91
 ENDING STATION 1054+97 1059+94 1064+91 1069+88
 LENGTH OF SUBLOT "L"
 WIDTH OF LANE

RANDOM NUMBERS

| SUBLOT | SUBLOT | SUBLOT | SUBLOT |
|--------|--------|--------|--------|
| SET A | | | |
| SET B | | | |

LONGITUDINAL LOCATION

| SUBLOT | L | A | X = L + XA | BEG. STA. | STA + X |
|--------|---|---|------------|-----------|---------|
| | | | | | |
| | | | | | |
| | | | | | |

TRANSVERSE LOCATION

| SUBLOT | WIDTH | B | W = WIDTH * C | W * B | OFFSET = 1 + W * B |
|--------|-------|---|---------------|-------|--------------------|
| | | | | | |
| | | | | | |
| | | | | | |

* ALWAYS MEASURE OFFSET FROM RIGHTHAND EDGE
 * STA APPROXIMATELY 1 FOOT FROM LONGITUDINAL AND TRANSVERSE JOINTS

Sampling **13**

13

Random Locations ASTM D3665
 Showing one sample per subplot

LOT 3

SUBLOTA SUBLOTB SUBLOTC SUBLOTD

1050+00 1054+97 1059+94 1064+91 1069+88

SAMPLE LOCATIONS = 0 Right Edge of Pavement

Sampling

14

AGE OF CURED CORES

- Cores for compressive strength can be cured in any of the following time limits:

12 hours ± 0.25 hours
 24 hours ± 0.5 hours
 3 days ± 2 hours
 7 days ± 6 hours
28 days ± 20 hours
 56 days ± 40 hours
 90 days ± 2 days

Today we will use the **28-day cure ± 20 hours.**

Sampling **15**

15

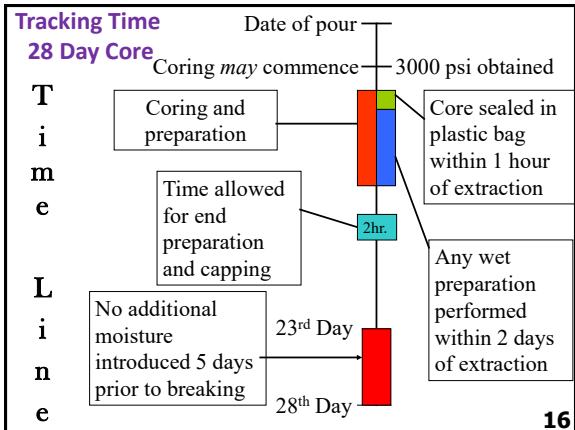

16

PROCEDURE - For a 28 Day Core

SAMPLING

- **Note the date**, when the concrete was placed. This date will be used to determine the testing day, which will be **28 days later**.
- Determine the size of the core.
 - **Less than 12" design thickness, obtain a 4" diameter core**
 - **12" or more design thickness, obtain a 6" diameter core**
- Engineer marks random sample using **ASTM D3665**.

17

17

- After **3,000 psi** is reached drill on the engineer's random marked spot

- Ensure the drill is perpendicular to surface and at least **6 inches** away from formed joints or obvious edges of concrete pour.
- NOTE: This minimum distance does not apply to the formed boundaries of structural members.

18

18

• When drilling, avoid creating ridges on the core surface by:

- Ensuring the drill is held steady
- Use plenty of water
- Use a sharp drill bit



19

19

- Drill until base is reached, using plenty of water.
- Carefully extract the drilled core.
- Note the date and time of extraction.



20

20

• After extracting the core from the hole, wipe off the surface water and allow the remaining surface moisture to evaporate.



21

21

• When the surface appears to be dry, write the following information on the side of the core:

- Job No.
- Route
- County
- Lot
- Sublot
- Station #

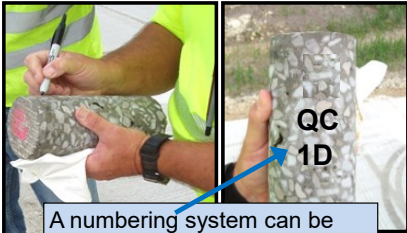

A numbering system can be used to identify cores. The main concern is assuring no doubt when and where the core was taken.

Drilling a core

22

22

• **NOTE:** AASHTO T 24 mentions cores may be placed in plastic bags or nonabsorbent containers, **MoDOT** prefers drilled cores to be placed inside sealed plastic bags.

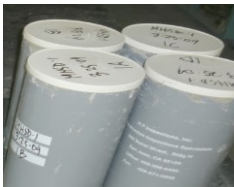

23

23

Within **one hour** from extracting and labeling the core, place it in a separate plastic bag.

- Maintain the core at ambient temperature and protect it from direct sunlight.
- For MoDOT projects, ambient temperature is defined as 60 to 80°F (16-26°C).



24

24

NOTE: If the core is leaving the QA inspector's possession;



***Place the sealed core in a tamper-proof bag immediately!**



- Transport the core to the testing lab as soon as possible.

25

25

Handle cores **carefully**. Do NOT drop, toss, or allow the core to tumble in transit. If any of these happen, contact the Resident Engineer (RE) immediately to get instructions on what to do next. A replacement core may be necessary.



Cracked core

26

26

AT THE LABORATORY



27

27

SAMPLE PREPARATION

- Any wet preparation such as “sawing” must be completed within **2 days** of the extraction date. (Unless MoDOT approves otherwise.)
- Keep cores sealed in separate bags or containers at all times except for the **2 hours** allowed for measuring, end preparation, and capping.

28

28

CORE THICKNESS

Within **2 days** of extraction:

- Measure and record core length for pavement thickness as extracted per **AASHTO T 148**.
- The diameter shall be at least 3.70 inches.



29

29

END PREPARATION

Complete sawing and end preparation in the **2-hour** window, minimizing any exposure to water.



30

30

END PREPARATION

- If the ends do not meet AASHTO T 22, saw the ends of cores prior to capping so that they meet the following:
 - **End Projections:** Shall not be greater than 0.2 inch (5mm) above end surfaces.
 - **End Surface:** Shall not depart from perpendicularity by a slope of more than 1:8d (d is average core diameter).

31

31

- After completing end preparation, wipe off surface moisture, allow the surfaces to dry, and place the cores in sealed plastic bags or containers.



NOTE:
Cores = drilled
Cylinders = molded

32

32

CORE LENGTH

- This should be completed within the **2-hour** window.
- After pavement thickness has been determined, saw cores to a Length/Diameter (L/D) ratio of **1.9 to 2.1** for testing and record the measurement. (2.0 is preferred)
- If the ratio (L/D) exceeds 2.1, reduce the length of the core so it meets 1.9 to 2.1.
- If (L/D) is less than 1.75 use a correction factor to the measured strength. (See Table 7.9.1)
- (L/D) greater than 1.75 does not require a correction factor.

L/D = Length to Diameter measurement

33

SPECIMEN PREPARATION

If possible, reduce the length of a core to L/D ratio of 2.0

$$\frac{8'' \text{ length}}{4'' \text{ diam.}} = 2.0$$

$$\frac{12'' \text{ length}}{6'' \text{ diam.}} = 2.0$$

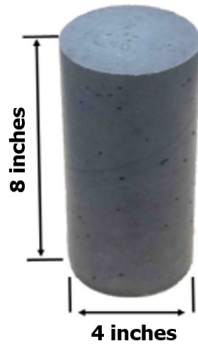

34

New Slide

34

CORE DIAMETER

- Measure two diameters at right angles to each other at the mid-height of the core and average them.
- The diameter must be at least **3.70 inches**, or at least 2 times the *NMAS whichever is larger.
*NMAS = Nominal Maximum Aggregate Size
- Report the average to the nearest **0.01 inch**.

Note: A core with less than 3.70 inches in diameter is permitted if the L/D is at least 1.0; report the reason for this exception.

35

35

- If the difference in the core diameters exceed **2%** of their average, report to the nearest **0.05 inch**.
- For Drilled Cores;
Do not test if the difference between the largest and smallest diameter exceeds 5% of their average.

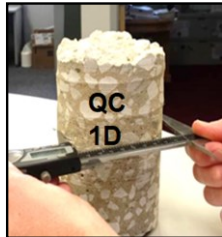

NOTE:

Do not mix this up with AASHTO T22 and molded cylinders. If any individual diameter of a cylinder differs from any other diameter of the same cylinder by more than 2% do not test.

36

Use Table 7.9.1 to correct the measured Compressive Strength for cores with L/D ratios equal to or less than 1.75.

| TABLE 7.9.1 | |
|-------------|----------------------------|
| L/D | Strength Correction Factor |
| 1.75 | 0.98 |
| 1.50 | 0.96 |
| 1.25 | 0.93 |
| 1.00 | 0.87 |

NOTE: Use interpolation to determine the correction factor for L/D values not given in the table.

37

37

MEASUREMENT

- Length for Bonded Caps (AASHTO T 231), determine the Average Length before and after capping, use the length after capping to compute the length-diameter ratio (L/D).
- Length for Unbonded Caps (ASTM C1231), or a core with ground ends, determine the Average Length of the core to the nearest 1 mm (0.05 inch) using a caliper as per AASHTO T 148.

38

38

The last wetting must be completed no less than **five days** prior to testing.

Allow the cores to remain in sealed plastic bags undisturbed with no additional moisture and ready to test, unless MoDOT stipulates otherwise.



Moisture Conditioning

39

39

CALCULATED DENSITY

- Weigh the core.
 - For bonded caps; weigh the core before capping.
 - For Unbonded caps; weigh the core just before testing.
- Calculate the average (L/D).
- Divide the weight by the volume of the core, calculated from the average diameter and length measurement.
- Record the calculated density to the nearest 1lb/ft³.

40

40

CAPPING

If the ends of the cores do not conform to the planeness requirements of AASHTO T 22, they shall be:

- Sawed or ground to meet AASHTO T 22
- or
- Capped per AASHTO T 231 (Bonded Caps)
- or
- Capped per ASTM C1231 (Unbonded Caps)

Capping

41

41

WHEN TO CAP THE CORE

Bonded

Un-Bonded



OR



AASHTO T 231

ASTM C1231

42

42

CURING CONTINUATION

- After completing end-preparation, and after bonded capping, wipe off surface moisture, allow the surfaces to dry, and place the core in a sealed plastic bag or airtight container.
- Cores are to remain in the sealed plastic bag/container for at least **5 days** after last being wetted before testing, unless MoDOT states otherwise.

43

43

TESTING

- On the **28th day** test the specimen in accordance with AASHTO T 22.



44

44

CALCULATIONS

- Calculate the compressive strength of each specimen using the computed cross-sectional area based on the average diameter of the specimen. (AASHTO T 22)
- If the ratio of the length to diameter (L/D) of the specimen is 1.75 or less, correct the result obtained multiplying by the appropriate correction factor shown in AASHTO T 24, Table 7.9.1.

45

45

REPORTING THE RESULTS as required by AASHTO T 22 with the addition of the following information:

- **Length** measure of core as drilled to the nearest 5mm (0.2 inch).
- **Reason** if diameter is less than 94mm (3.70 inch).
- **Length** T148, of the core before and after capping or end preparation to the nearest 2mm (0.1 inch), and average diameter of core to the nearest 0.2mm (0.01 inch) or 2mm (0.1 inch).
- **Compressive strength** to the nearest 0.1MPa (10 psi) when the diameter is measured to the nearest 0.2mm (0.01 inch), and to the nearest 0.5 Mpa (50 psi) when the diameter is measured to the nearest 2mm (0.1 inch), after correction for length/diameter ratio when required.

46

46

REPORTING MOISTURE CONDITION HISTORY

- Date concrete was placed, if known.
- Date and time obtained and first placed in sealed bag.
- If water was used during end preparation, the date and time end preparation was completed, and the core placed in sealed bag.
- Date and time when tested.
- Nominal maximum size of concrete aggregate.
- Calculated density to the nearest 20kg/m³ (1lb/ft³).
- The location, shape, and size of embedded metal, if MoDOT permits testing cores with embedded metal.
- Descriptions of defects in cores that could not be tested and any deviations from AASHTO T 24.

47

47

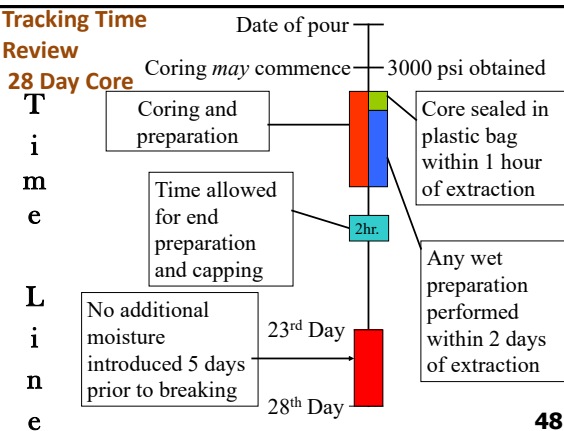

48

48

SAWED BEAMS



49

49

SAWED BEAMS



50

50

Beam Dimensions

- A beam specimen for the determination of Flexural Strength should have a square cross section.
- In general, cross section = 150mm x 150mm (6" x 6") for nominal maximum size aggregate of 1" or more.
- But can be, Cross section = 100mm x 100mm (4" x 4") for nominal maximum size aggregate of 1" or less.

51

51

Beam Dimensions

- Cross sectional dimensions should be within $\pm 2\%$ of these nominal dimensions above.
- The test specimen should be at least 50mm (2") longer than three times the nominal depth.
- **Length = At least 530 mm (21 inches)**
- **Sawing Beams**
 - Sawed Surfaces shall be smooth, plane, parallel, and free from steps, ridges, and grooves.
 - Handle with care to avoid chipping or cracking.

52

52

Moisture Conditioning & Testing

- Cover surfaces of sawed beams with a wet burlap and plastic sheeting during transport and storage.
- Test the specimen within **7 days** of sawing.
- Submerge the beams in lime-saturated water at $73.5 \pm 3.5^\circ\text{F}$ ($23.0 \pm 2.0^\circ\text{C}$) for at least 40 hours immediately prior to flexural testing.
- Test the beam promptly after removal from water storage.
- Cover the beam with wet burlap between the removal from water storage to testing, in accordance with AASHTO T 97.

53

53

REPORTING (Beams)

- Report the location with respect to the position of the concrete as placed and the position of the sawed surfaces.
- Report the moisture condition at the time of testing as well as the orientation of finished, sawed, and tension faces with respect to their positions in the test apparatus.
- Report the results in accordance with the applicable provisions of AASHTO T 97.

Sawed Beams

54

54

CORE LOCATIONS

PROJECT _____ ROUTE _____ MIX NO. _____

LOT NO. _____ DATE _____ TECHNICIAN _____

SUBLOT _____

BEGINNING STATION "STA" _____

ENDING STATION _____

LENGTH OF SUBLOT "L" _____

WIDTH OF LANE _____

RANDOM NUMBERS

| | SUBLOT | SUBLOT | SUBLOT | SUBLOT |
|-------|--------|--------|--------|--------|
| SET A | | | | |
| SET B | | | | |

LONGITUDINAL LOCATION

| SUBLOT | L | A | X = L x A | BEG. STA | STA + X |
|--------|---|---|-----------|----------|---------|
| | | | | | |
| | | | | | |
| | | | | | |
| | | | | | |

TRANSVERSE LOCATION

| SUBLOT | WIDTH | B | W = WIDTH - 2' | W x B | OFFSET = 1 + W x B |
|--------|-------|---|----------------|-------|--------------------|
| | | | | | |
| | | | | | |
| | | | | | |
| | | | | | |

- ALWAYS MEASURE OFFSET FROM RIGHTHAND EDGE
- STAY APPROXIMATELY 1 FOOT FROM LONGITUDINAL AND TRANSVERSE JOINTS

Example Problem

Length = 1988ft Width = 28ft Depth = 12in.

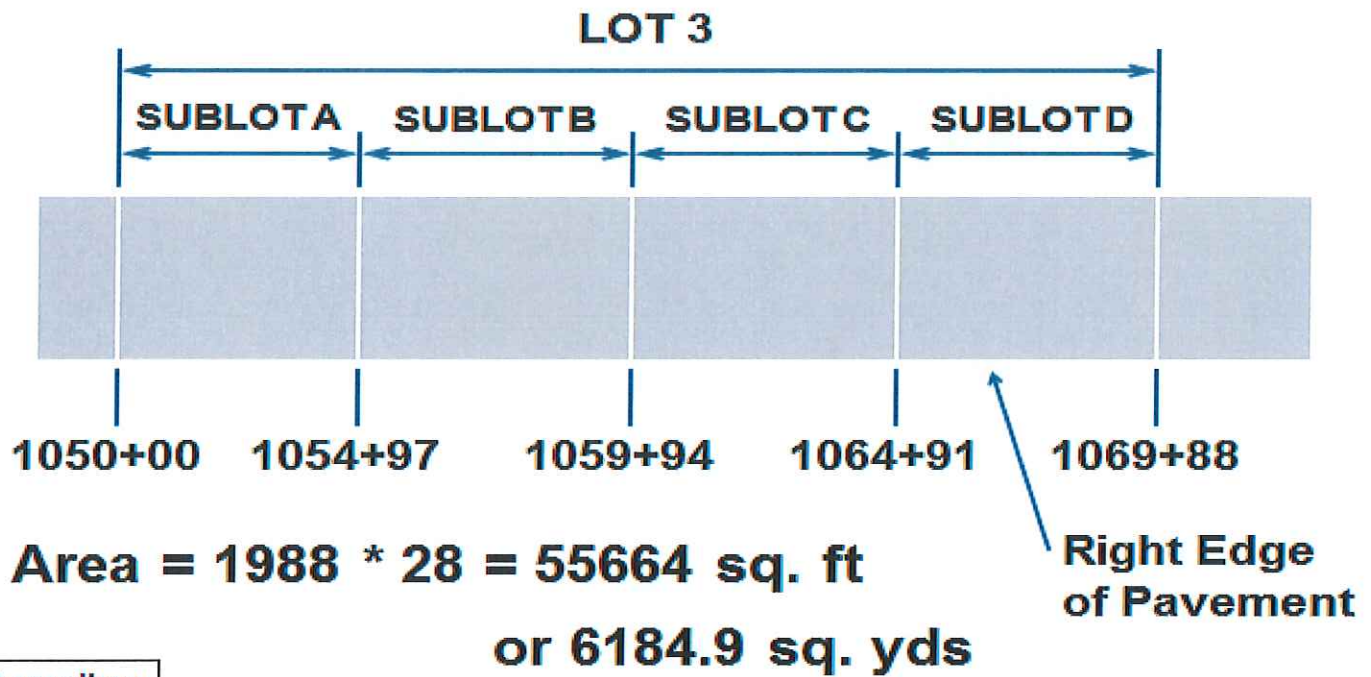

Random Locations ASTM D3665 Showing one sample per subplot

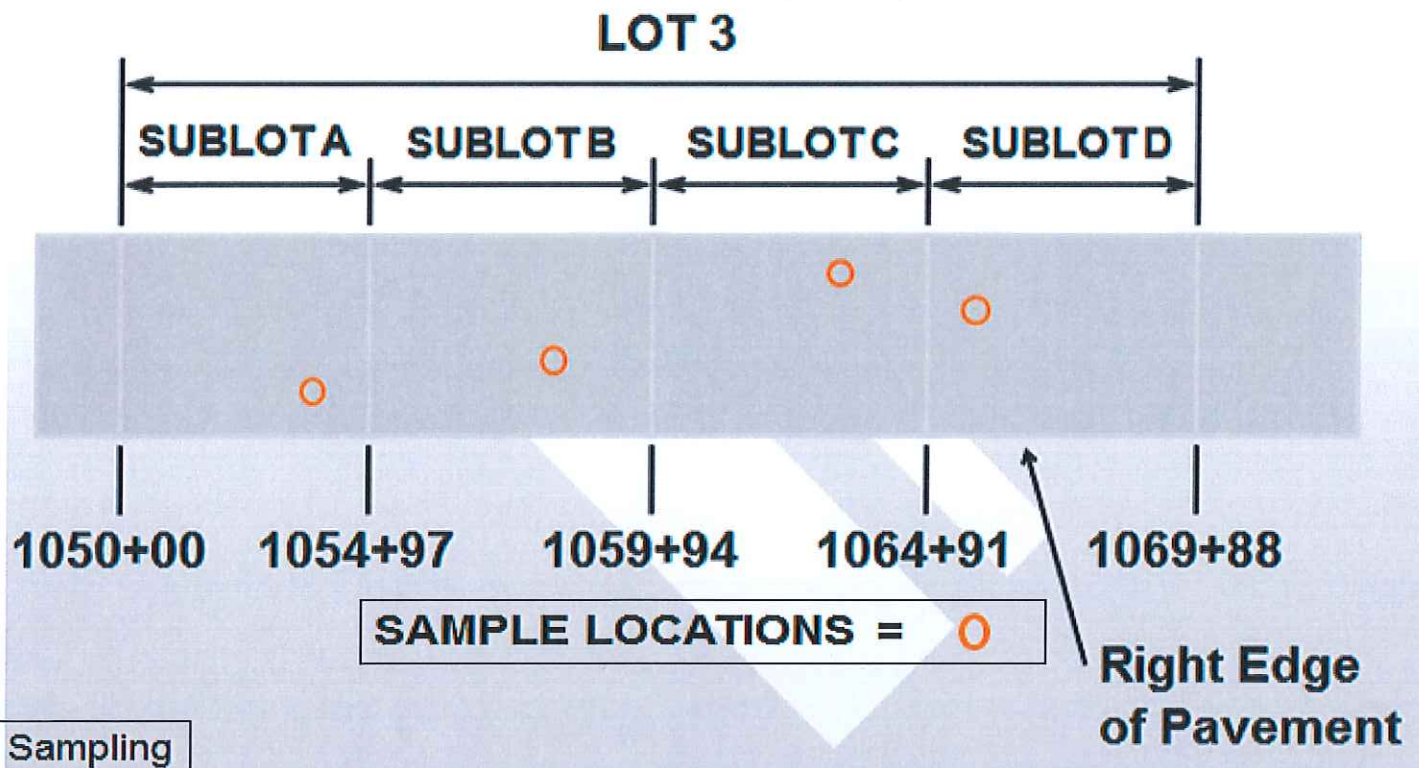

CORE LOCATIONS

PROJECT JX12345 ROUTE 66 MIX NO. _____
 LOT NO. 3 DATE _____ TECHNICIAN Charlie Wate

| SUBLOT | A | B | C | D |
|--------------------------------|---------|---------|---------|---------|
| BEGINNING STATION "STA" | 1050+00 | 1054+97 | 1059+94 | 1064+91 |
| ENDING STATION | 1054+97 | 1059+94 | 1064+91 | 1069+88 |
| LENGTH OF SUBLOT "L" | 497 | 497 | 497 | 497 |
| WIDTH OF LANE | 28 | 28 | 28 | 28 |

RANDOM NUMBERS

| | SUBLOT A | SUBLOT B | SUBLOT C | SUBLOT D |
|--------------|-------------|-------------|-------------|-------------|
| SET A | 0.998 | 0.749 | 0.517 | 0.253 |
| SET B | 0.239 | 0.291 | 0.858 | 0.761 |

LONGITUDINAL LOCATION

| SUBLOT | L | A | X = L x A | BEG. STA | STA + X |
|--------|-----|-------|-----------|----------|-----------|
| A | 497 | 0.998 | 496 | 1050+00 | 1054+96 |
| B | 497 | 0.749 | 372.3 | 1054+97 | 1058+69.3 |
| C | 497 | 0.517 | 256.9 | 1059+94 | 1062+50.9 |
| D | 497 | 0.253 | 125.7 | 1064+91 | 1066+16.7 |

TRANSVERSE LOCATION

| SUBLOT | WIDTH | B | W = WIDTH - 2' | W x B | OFFSET = 1 + W x B |
|--------|-------|-------|----------------|-------|--------------------|
| A | 28 | 0.239 | 26 | 6.2 | 7.2 |
| B | 28 | 0.291 | 26 | 7.6 | 8.6 |
| C | 28 | 0.858 | 26 | 22.3 | 23.3 |
| D | 28 | 0.761 | 26 | 19.8 | 20.8 |

- ALWAYS MEASURE OFFSET FROM RIGHTHAND EDGE
- STAY APPROXIMATELY 1 FOOT FROM LONGITUDINAL AND TRANSVERSE JOINTS

Tracking Time Review

28 Day Core

T
i
m
e

L
i
n
e

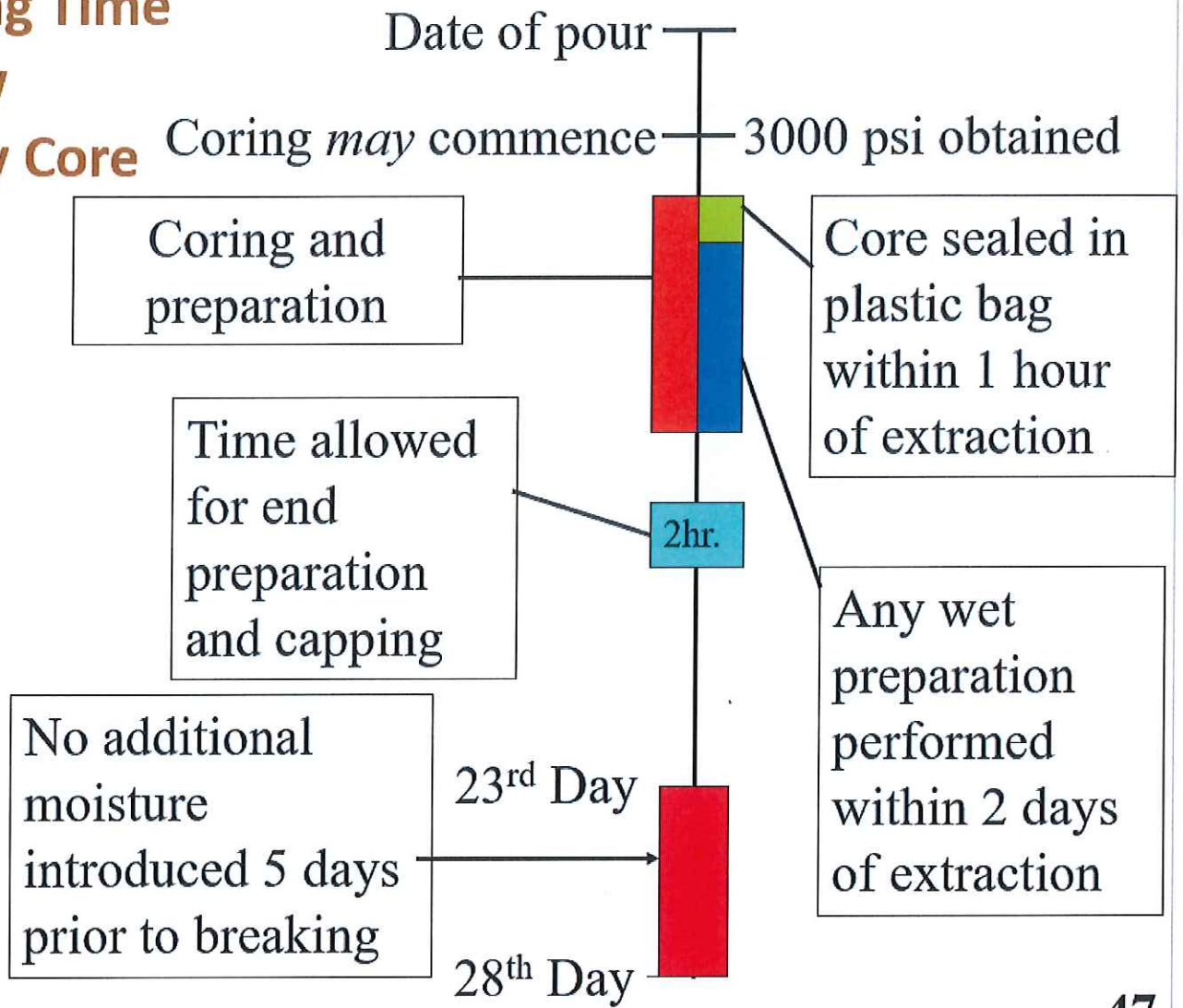

**AASHTO T 24: Obtaining and Testing
Drilled Cores of Concrete and Sawed Beams**

PROFICIENCY CHECKLIST

Applicant _____

Employer _____

| PART I - CORES | Trial 1 | Trial 2 |
|---|------------|------------|
| 1. Cores not taken until 3,000 psi is achieved on Maturity Meter | | |
| 2. Size of core taken corresponds to design thickness of pavement a) For pavements less than 12" take a 4" core b) For pavements 12" or greater take a 6" core | | |
| 3. Ensure core bit is perpendicular to the driving surface | | |
| 4. Extract Core , taking care not to damage or drop a) Wipe surface water from core and allow remaining surface moisture to evaporate b) Mark core for identification | | |
| 5. Maintain the integrity of moisture consistent with AASHTO T 24 a) Within 1 hour of extraction, place core in a plastic bag or non-absorbent container b) Maintain ambient temperature of core 60-80°F (16-26°C) and out of direct sunlight | | |
| 6. Determine the length (Pavement Depth) of core in its original form according to AASHTO T 148 | | |
| 7. Determine the mean diameter of the core, check tolerances | | |
| 8. Cores will be tested at 28 days of age a) If water is used during preparation, complete as soon as practicable within 2 days of drilling and extraction b) Minimize exposure to water during end preparation c) Core remained sealed except; • During measuring and end preparation procedure • A maximum of 2 hour to permit capping d) Cores remained sealed in container a minimum of 5 days after last being wetted | | |
| 9. Reporting a) Core length per AASHTO T 148 b) Test results per AASHTO T 22 c) Dimensions per AASHTO T 24 d) Dates of all procedures during the 28 days, from extracting to testing a core AASHTO T 24 e) Locations of embedded metal and defects if any f) Report any deviations from AASHTO T 24 | | |

| PART II SAWED BEAMS | | |
|---|--|--|
| 1. Sawing Beam sawed surfaces smooth, plane, parallel and handled with care to avoid damage | | |
| 2. Beam Dimensions Cross section = 150mm x 150mm (6" x 6") Width = by size of aggregate and thickness of slab Length at least 530mm (21") | | |
| 3. Maintain the integrity of moisture consistent with AASHTO T 24 | | |
| a) Beam covered with moist wet burlap and plastic sheeting during transport and storage | | |
| b) Beams submerged in lime-saturated bath at $73.5 \pm 3.5^{\circ}\text{F}$ ($23.0 \pm 2.0^{\circ}\text{C}$) for at least 40 hours | | |
| c) Test the beam promptly after removal from water and covered with moist cover until testing | | |
| 4. Testing | | |
| a) Beam tested within 7 days of sawing | | |
| b) Beam tested per AASHTO T 97 | | |
| 5. Reporting | | |
| a) Test results per AASHTO T 97 | | |
| b) Moisture conditions | | |

Pass Pass

Fail Fail

Examiner: _____ Date: _____

AASHTO T 148

Measuring Length Of Drilled Concrete Cores

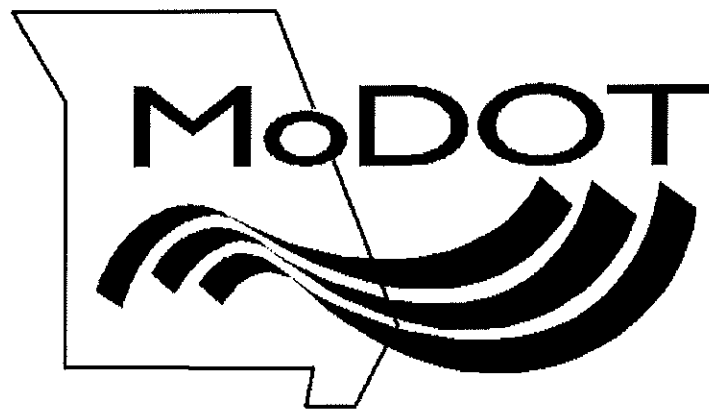

AASHTO T 148

Measuring Length of Drilled Concrete Cores



1

SCOPE

- This test method covers determination of the thickness of a concrete pavement, slab, or structural element by measuring the length of a core drilled from a concrete structure.



2

2

SIGNIFICANCE AND USE

- This method is used to determine the compliance of concrete construction with design specifications. It is especially important in determining the thickness of pavements and other slab construction.
- This test method requires that at least one end of the core be a finished or formed surface.

3

3

EQUIPMENT

- **9-point Measuring Device**
- **Measuring Rod** : Rounded to a radius of 3 mm, with a scale spacing of 1.0mm(0.10 in)
- **Caliper** (for measuring diameter)
- **Verification Gauges**: Used for verifying the 9-point measuring device



4

4

Equipment – Verification Gauges

Verification Cylinder for Core Length Device

Right circular cylinders with flat ends and a diameter approximately equal to the diameter of cores intending to be measured and a length in the range of the required measurements.



5

5

Equipment – 9 Point Measuring Device



6

6

Equipment – Measuring Device

- Requirements:
 - Measures along the axis of the core.
 - Lower end holds core vertical using three symmetrically spaced supports.
 - Supports will be posts or studs made of hardened steel, ends which bear against the core will be rounded to a radius not less than 1/4" and not more than 1/2".
 - Accommodates specimens with lengths over a range of at least 100 to 250 mm (4"-10")

7

7

Equipment – Measuring device

- Measures cores that are full depth of the concrete pavement.
- Measures length at the center of the core and at eight points spaced at equal intervals along the circumference of a circle, with the center point at the center of the core whose radius is not less than 1/2 nor more than 3/4 of the radius of the specimen.

8

8

Equipment – Measuring Rod

Measuring Rod



- **The measuring rod or rods will be rounded to a radius of 1/8" on the end that contacts the core.**
- The measuring rod on one end is divided into tenths of an inch.
 - It is recommended to color in the grooves to make it easier to read by giving the 1/2" and 1" marks a different color.
- The 0.1" marks on the measuring rod will be verified.

9

9

TEST SPECIMENS

- Cores used as specimens for length measurement shall be obtained by AASHTO T24 and be in every way representative of the concrete in the structure from which they are removed.
- The core shall be drilled with the axis normal to the surface of the structure, and the ends shall be free from all conditions not typical of the surfaces of the structure.
- If a drilled core included particles of aggregate bonded to the bottom surface, the bonded particles shall be removed by wedging or by chisel and hammer to expose the lower surface of the concrete.

10

10

PROCEDURE

- First, verify the apparatus so that errors caused by mechanical imperfections in the apparatus are known.
- If the difference between the length measured with the apparatus and the known length of the verification gauge exceeds 0.25 mm (0.01 inch), apply corrections to the core length measurements.

11

11

Equipment Verification:

Using a tape measure take a rough measurement to the tallest point. This measurement will help to determine what size Verification Cylinder you will need to use.



12

12

Verification Cylinder for Core Length Device



Verification Cylinder for Core Length Device

Used with the H-2939 Core Length Measuring Device to verify cylinder lengths.

H-2939.40: Verification Cylinder, 4" x 8"
H-2939.60: Verification Cylinder, 6" x 12"

Equipment – Verification **13**

13

Using a 4X8 or a 6 X12 Verification Cylinder with flat ends and a diameter approximately equal to the diameter of cores intending to be measured and a length in the range of the required measurements.



Note 1—To permit verification of different core length measurements, multiple verification cylinders of different lengths may be used.

Equipment – Verification **14**

14

PROCEDURE

- Cores that show abnormal defects or have been damaged will be replaced.
- Any particles of the base material that are attached to the bottom of the core shall be removed; may use a wire brush or chisel.
- Care should be exercised not to remove any of the concrete when removing attached particles.

15

15

Insert the core, placing the driving surface down against the three hardened steel supports.



Procedure

16

16

Take 9 Measurements

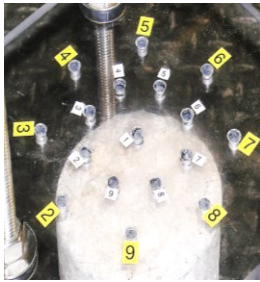

The plexi-glass plate has a hole in the center with two sets of eight holes in a circumference around it.

Use the inside set for 4" diameter cores.

Use the outside set for 6" diameter cores.

Note: It is useful to label the holes as shown in the picture.

Procedure

17

17



- Insert the measuring rod into hole #1 and bring to rest on the core.
- Take the verified set height of the device and from the core surface start counting the **tenths** of an inch on the rod backwards from that number, interpolating the nearest **.05 inch**.
- Record this as the height for that hole.
- Repeat process for the remaining 8 holes.

Procedure

18

18

Example:

From the top of the core count backwards each **tenth** of an inch up to the bottom of the plexi-glass.

Interpret to the nearest **0.05** Inch. The core shown would be 13.35 inches.

Record each measurement to the nearest **0.05** inch.

Average the nine measurements expressed to the nearest 0.1 inch.

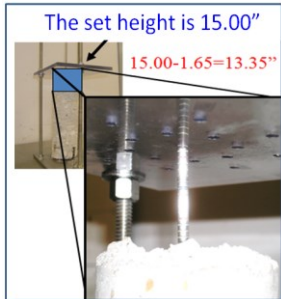

19

19

- If one or more of the eight locations are found not to be representative of the plane of the core, the core shall be rotated slightly, and nine new measurements taken.

NOTE: Pavements with open-graded aggregate cannot use this provision because of the great number of projections or voids.



Procedure

20

20

REPORTING

- Take 9 measurements and record each to the nearest **0.05"**.
- The length of the concrete core is the average of the nine measurements reported to the nearest **0.1"**.

Example Record:

| Core Thickness Report | | | |
|-----------------------|-------------------------|-----------------------|-------------------|
| Date: 08/03/2023 | | ID: BR549 | Core: #1A |
| Measurement | Calibrated Length (in.) | Measured Length (in.) | Core Length (in.) |
| 1 | 16 | 1.25 | 14.75 |
| 2 | 16 | 1.35 | 14.65 |
| 3 | 16 | 1.30 | 14.70 |
| 4 | 16 | 1.40 | 14.60 |
| 5 | 16 | 1.20 | 14.80 |
| 6 | 16 | 1.10 | 14.90 |
| 7 | 16 | 1.15 | 14.85 |
| 8 | 16 | 1.20 | 14.80 |
| 9 | 16 | 1.25 | 14.75 |
| Reported Length (in.) | | | 14.8 |

Updated slide

21

21

Common Errors:

- Not verifying the measuring rod.
- Misreading the measuring rod.
- Adding when you should be subtracting or subtracting when you should be adding.
- Improperly setting the height of the upper plate.
- Not centering the core.
- Not removing attached foreign particles.
- Removing some of the concrete when removing foreign particles.

22

AASHTO T 148: Measuring Length of Drilled Concrete Cores

PROFICIENCY CHECKLIST

Applicant _____

Employer _____

| | Trial # | 1 | 2 |
|---|---------|---|---|
| Verification | | | |
| 1. Verified the measuring device | | | |
| Procedure | | | |
| 1. Removed any base particles from the core | | | |
| 2. Inserted the core, placing the driving surface down onto the studs | | | |
| 3. Centered core in the measuring device | | | |
| 4. Used the correct holes for the core size | | | |
| 5. Nine locations measured to the nearest 0.05" | | | |
| 6. Measurements from the bottom of the top plate subtracted from the calibrated height. | | | |
| 7. Record the calculated lengths to the nearest 0.05" | | | |
| 8. Reported the average length of 9 measurements to 0.1" | | | |

PASS PASS

FAIL FAIL

Examiner: _____ Date: _____

AASHTO T 231

Capping Cylindrical Concrete Specimens



AASHTO T 231

T231 Capping Cylindrical Concrete Specimens



Revised 08/16/2023

1

SCOPE

This method covers the apparatus, materials, and procedures for . . .

- A. Capping freshly molded concrete cylinders with neat cement.
- B. Capping hardened cylinders and drilled concrete cores with sulfur mortar or high strength gypsum plaster.

2

2

SIGNIFICANCE AND USE

- This practice describes procedures for providing plane surfaces on the end surfaces of freshly molded concrete cylinders, hardened cylinders, or drilled concrete cores when the end surfaces do not conform with the planeness and perpendicularity requirements of applicable standards.

3

3

EQUIPMENT

- **Alignment Devices:**

Suitable alignment devices such as guide bars shall be used in conjunction with capping plates to ensure that no single cap will depart from the perpendicularity of the cylindrical specimen by more than **0.5 degrees**.



(Equal to the slope of approximately ¼ in. in 12 in.)

4

4

- **Melting Pot for Sulfur Mortar:** Equipped with automatic temperature controls and made of metal.

SAFETY: If not a peripheral heating pot, place a metal rod or metal ladle in the pot that touches the bottom and projects above the surface of the fluid sulfur mix as it cools to avoid development of pressure under the crust of sulfur.

Equipment Continued

5

5

- **Hood** to exhaust the Sulfur fumes:

- **SAFETY:** The Capping area must be well ventilated.
- **SAFETY:** The flash point of sulfur is approximately 440°F and can ignite; if it does, quickly put a cover on it.

Ladle,
square ruler,
3 mm Allen wrench,
Calipers,
Wire brush

Equipment Continued

6

6

- **Feeler Gauge 0.002 in.**
- **Masonry Stone** - used to remove concrete protrusions on cylinders by rubbing
- **Gloves, Apron, Safety Glasses**

NOTE: See the Appendix for more information on equipment.

Equipment Continued 7

7

Capping Materials for Bonded Caps

- The following **4** materials are suitable to use for capping:
 - 1. Sulfur Mortar** - Covered in this certification
 NOTE: Proprietary or laboratory prepared sulfur mortars are permitted if allowed to harden a minimum of **2 hours** before testing concrete with strength less than 35 Mpa (5000 psi). For concrete strengths of 35MPa (5,000 psi) or greater, sulfur mortar caps must be allowed to harden at least **16 hours** before testing, unless a shorter time has been shown to be suitable.

8

8

- 2. Neat Hydraulic Cement Paste** –
 See Appendix for more information.
- 3. Neat Portland Cement Paste** –
 Neat cement paste caps will shrink and crack on drying and therefore should be used only for specimens that are to be moist-cured continuously until time of testing.
 See Appendix for more information.
- 4. High Strength Gypsum Plaster** –
 Do not immerse cores with Gypsum caps in water and do not store them in a moist room for more than 4 hours. If stored in a moist room, the plaster caps shall be protected against water dripping on their surfaces.
 See Appendix for more information.

Capping Materials Continued 9

9

QUALIFYING CAPPING MATERIALS

- Test capping materials for compressive strength per AASHTO T106M/T106 before using.
- If sulfur mortar or high strength gypsum plaster are to be used to test concrete with a strength greater than 7000 psi, manufacturer or the user of the material must provide documentation. (Keep this in the quality control manual.)
- The strength of the capping material shall be determined on receipt of a new lot and at intervals not exceeding **3** months.
(Keep the test reports in the lab's quality control manual.)

10

10

- The compressive strength of capping materials shall be determined by testing 2-in cubes following the procedure described in AASHTO T106M/T106.
- If a given lot of the capping material fails to conform to the strength requirements, it shall **not** be used.



See the [Appendix](#) for more information.

Qualifying Capping Materials

11

11

SPECIMENS – Freshly Molded

- Use only Neat Portland Cement Paste to cap freshly molded cylinders.
- Make caps as thin as practical.
- Do not apply the neat paste to the exposed end until the concrete has ceased settling in the molds, generally from 2 to 4 hours after molding.

More information in the [Appendix](#).

12

12

SPECIMEN PREPARATION

- Specimens will be prepared as defined in AASHTO T23 & T24 prior to capping.
- Core measured per AASHTO T148.
- If necessary, reduce the length of a core to L/D ratio of 2.0
- No projections to exceed 0.2 in. (5 mm) above the end surface.
- The end surface shall not depart from perpendicularity to the longitudinal axis by more than 0.5 degrees.

13

13

END CONDITION

Check the ends using a square.



14

14

END CONDITION

Checking the end conditions of an uncapped cylinder using a square ruler and a 3mm (1/8" in.) Allen wrench:

Tap the wrench several times across the top of the cylinder where the ruler meets the cylinder, to check for gaps.

Move the ruler around to check positions 1, 2, and 3. Flip the cylinder and repeat.

- If the end of the cylinder exceeds 3mm, cut and grind to correct.

New Slide

15

15

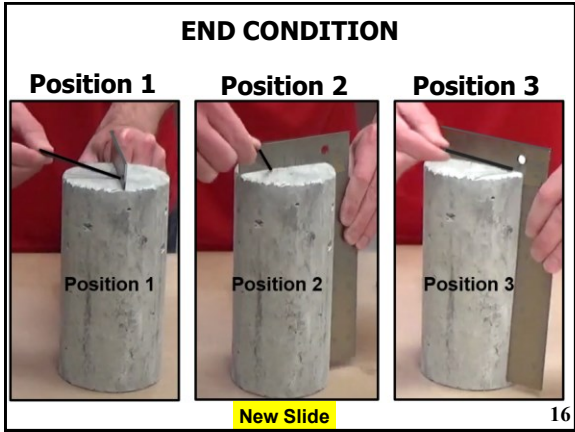

16

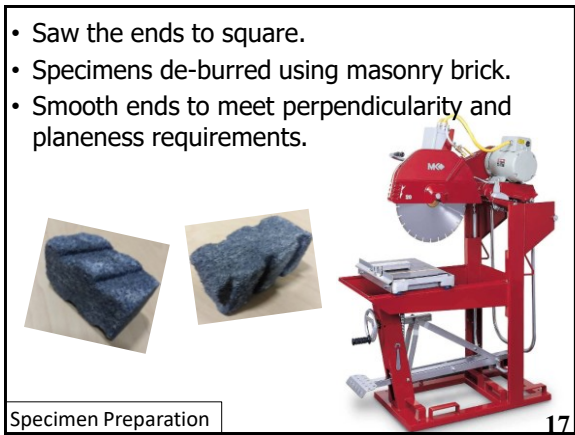

17



18

Capping with Sulfur Mortar

SAFETY: Wear protective clothing such as an apron, safety glasses, and gloves before using hot melted sulfur.

SAFETY: Plug sulfur pot in **WITHOUT** the use of an extension cord.

SAFETY : Keep **water** away from molten sulfur mortar!

19

19

- Fill sulfur pot 2/3 full of flake sulfur.
- Preheat to about 265°F (130°C).
- Periodically check the temperature with an all-metal thermometer.
- After heating sulfur 5 times, discard.
- When adding fresh sulfur mortar ensure it is **dry**.

Capping with Sulfur Mortar

20

20

- Select a clean alignment device that fits the specimen.
(4" or 6" in diameter)
- Check that the plate is free of gouges or grooves greater than 0.25mm (0.010in) deep.

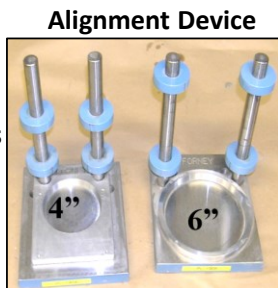

Capping with Sulfur Mortar

21

21

Setting up the Alignment Blocks

The bottom alignment block should be placed approximately one and a half inches (1 1/2") up from the top of the capping plate, regardless of the core or cylinder size.

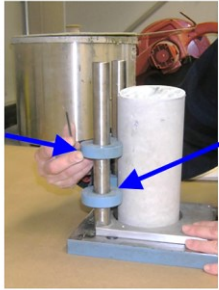

The top alignment block is placed approximately two-thirds of the way between the bottom block and the top of the core or cylinder.

Capping with Sulfur Mortar

22

22

Practice Setting the Core

This will help ensure that you won't drop the core or cylinder into hot sulfur and splash it on you. (Wear protective clothing).



Capping with Sulfur Mortar

23

23

Oiling the Capping Plate

- When sulfur is melted and has reached temperature, lightly oil the base of the alignment device.
 - This should be performed before each cap.
- Use oil or a non-stick cooking spray.



Capping with Sulfur Mortar

24

24

Molten Sulfur Mortar

- Sulfur mortar is ready at approximately 265°F (130°C). **Discard after 5 uses.**
 - Sulfur separates and develops an oily film.
 - Sulfur also builds up on the ladle, clean it by striking it with the rawhide mallet.

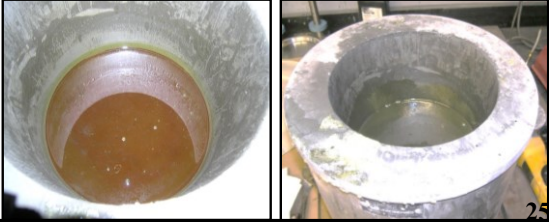

25

Warming the Plates

- Warm the capping plate by filling it with molten sulfur mortar.
- Allow the sulfur to cool and harden. (in about 45 seconds it will turn to a dull color).
- Hit the capping plate with a rawhide mallet on both sides to remove sulfur from the plate.



If a tool is used to facilitate getting the harden sulfur loose, be careful not to gouge the plate.

Capping with Sulfur Mortar

26

26

Capping a Specimen

- Ensure that the ends of the specimen are free of moisture.
- Lightly oil the capping plate.
- Stir the sulfur, ladle into the capping plate.
- Quickly set the specimen into the sulfur, being sure to keep it against the alignment blocks.



27

27

Capping a Specimen

- Continue to hold the test specimen against the alignment blocks for approximately 45 seconds till sulfur hardens.

(The edges of the sulfur will turn flat or dull as it cools.)



Capping with Sulfur Mortar

28

28

Capping a Specimen

- After the sulfur has hardened, tap the plate with the rawhide mallet on both sides of the specimen.
- Gently twist the specimen and pull straight up, being careful not to hit the cap against the bottom alignment blocks.



29

29

Checking Finished Caps (Daily Check)

During each day's capping operation, check the planeness, soundness, and thickness of the caps prior to compression testing on at least **3** specimens, selected at random, representing the start, middle, and end of a run.

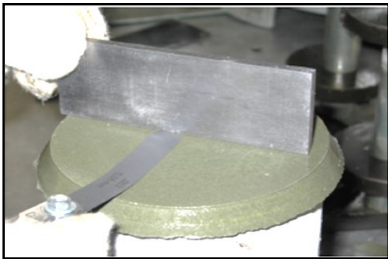

30

30

Soundness Check

- Check soundness by using a metal object; lightly tap or rub the cap. If a hollow sound is produced, an unsatisfactory cap is indicated. Remove the sulfur cap and recast. If no hollow sound is heard, the cap is good for soundness check.



Note: A bad cap can be removed from the end of the specimen using taps from the mallet.

31

31

Planeness Check

- Using a straight edge and feeler gage, check to ensure the cap is within 0.002 in. (0.05mm) of planeness at three different diameters.



Record the results.

- Check for hollow areas. If caps fail to satisfy the planeness requirement or has hollow areas, remove and reapply the caps.

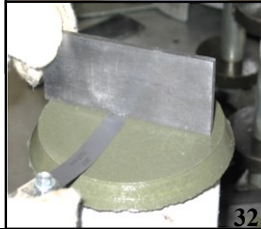

32

32

Cap Thickness Check (After Testing)

- After completing the compression test, recover at least 6 pieces of capping material from the top of the selected specimen (can use hammer and chisel). The pieces shall be selected at random and be distributed over the entire area of the cap. The selected pieces shall have double bonded completely from the concrete.

33

33

- Measure and record the thickness of the pieces to the nearest 0.01 in. (0.2mm) using a micrometer or caliper. Compare the average and maximum thickness with the values in Table 1, record the results of the thickness determination in the Quality Control document.

Cap Thickness

34

34

Strength and Thickness Table 1

Compressive Strength and Maximum Thickness of Capping Materials

| Cylinder Compressive Strength Mpa (psi) | Minimum Strength of Capping Material | Maximum Average thickness of Cap | Maximum Thickness Any Part of Cap |
|---|---|----------------------------------|-----------------------------------|
| 3.5 to 50 Mpa (500 to 7000 psi) | 35MPa (5000 psi) or Cylinder Strength Which ever is greater | 6mm (1/4") | 8mm (5/16") |
| Greater than 50MPa (7000 psi) | Compressive strength not less than cylinder strength, except as provided in 5.1.1 | 3mm (1/8") | 5mm (3/16") |

35

35

Protecting Specimens After Capping

- Moist-cured specimens shall be maintained in a moist condition between the completion of capping and the time of testing by returning them to moist storage.

- A. A drilled core is returned to its plastic bag.
- B. A concrete cylinder is wrapped in wet burlap and returned to moist storage.

- Do not test capped specimens before the capping material has had sufficient time to develop the required strength.

36

36

CALCULATIONS
For Bounded Capped Specimens

Final Length(L)/Diameter(D) Ratio will be determined after capping:

$$\frac{\textit{Average Length}}{\textit{Average Diameter}} = \mathbf{L/D}$$

37

37

REPORTING

- Record in a Quality Control Document or Manual the following:
 - Any documentation from manufacturer on the compressive strength of capping material.
 - Three-month qualification test reports on the 2-inch cubes when checking compressive strength of capping material.
 - Cap thickness check measurements
 - Planeness check measurements
 - Soundness check

38

38

AASHTO T 231: Capping Cylindrical Concrete Specimens

PROFICIENCY CHECKLIST

Applicant _____

Employer _____

| | 1 | 2 |
|---|---|---|
| Trial # | | |
| General | | |
| 1. Capping plates and alignment device checked and in good condition | | |
| 2. Qualified capping material tested for strength every 3 months and reports are kept in a Quality Control Manual | | |
| 3. Test specimens prepared and cured in accordance with AASHTO T 23, and T 24 | | |
| 4. Test specimens measured per AASHTO T 148 | | |
| 5. End conditions are checked | | |
| - Removed coatings or deposits and roughed with a wire brush if needed | | |
| - Uncapped end from a plane is perpendicular to the axis not to exceed 0.125 in (3mm) | | |
| 6. Types of Capping Material | | |
| High Strength Gypsum Plaster | | |
| Neat Hydraulic Cement Paste | | |
| Neat Portland Cement Paste | | |
| Sulfur Mortar | | |
| Sulfur Mortar Capping was Used, Procedure Below | | |
| 1. Sulfur mortar heated to about 265°F (130°C) | | |
| 2. Sulfur pot 2/3 full, added only dry sulfur (Discarded sulfur after heated 5 times) | | |
| 3. Selected the correct size of alignment device and set up the blocks accordingly | | |
| 4. Lightly oiled the plate | | |
| 5. Warmed the capping plate with hot sulfur, allowed to cool, and removed | | |
| 6. Lightly oiled the plate again | | |
| 7. Set the specimen into the sulfur keeping it against the alignment blocks | | |
| 8. Waited till sulfur hardened | | |
| 9. Tapped the plate with a rawhide mallet on both sides of the specimen | | |
| 10. Removed the specimen with cap without damaging it, repeated steps for the other end | | |
| 11. Checked finished caps for soundness and planeness of no more than 0.002 in (0.05mm) | | |
| 12. Stored sulfur capped specimen in a moist condition until tested | | |

PASS PASS

FAIL FAIL

Examiner: _____ Date: _____

ASTM C1231

Use of Unbonded Caps in Determination of Compressive Strength of Hardened Cylindrical Concrete Specimens

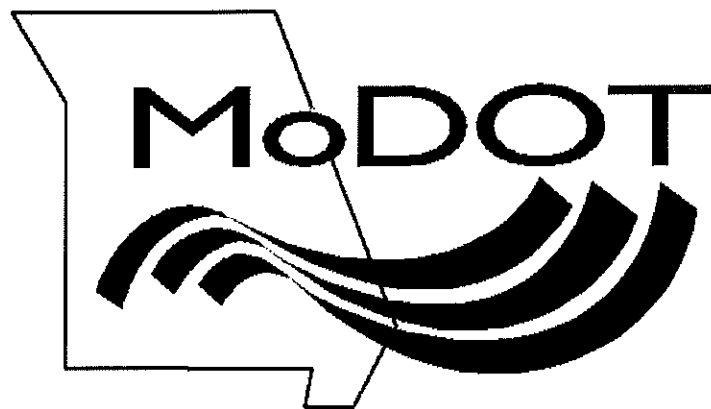

ASTM C1231

Use of Unbonded Caps in Determination of Compressive Strength of Hardened Cylindrical Concrete Specimens



Rev: 09/13/2023

1

SCOPE, SIGNIFICANCE AND USE

This practice covers requirements for a capping system using unbonded caps for testing concrete cylinders molded in accordance with AASHTO T23 , or cores obtained in accordance with Test Method AASHTO T24 in lieu of capping systems described in AASHTO T231 (Sulfur Capping).

2

2

Unbonded neoprene pads are permitted for a specified number of uses up to a certain concrete strength level and then require qualification testing.

Qualification testing is required for all elastomeric materials other than neoprene regardless of the concrete strength.



Significance and Use

3

3

Unbonded caps are not to be used for compressive strength below 1,500 psi or above 12,000 psi.

Note: Values stated in either SI units or inch-pound units are to be regarded separately as standard. The values stated in each system may not be exact equivalents; therefore, each system shall be used independently of the other.

Significance and Use

4

4

- **Pad** – an unbonded elastomeric pad



- **Unbonded Cap** – A metal retainer and an elastomeric pad



5

5

The elastomeric pads deform in initial loading to conform to the contour of the ends of the test specimens, they are restrained from excessive lateral spreading by plates and metal rings to provide a uniform distribution of load.

Significance and Use

6

6

MATERIALS AND EQUIPMENT

Materials and equipment necessary to produce ends of reference specimens that conform to planeness requirements of Test methods AASHTO T22 (Testing Compressive Strength) and AASHTO T231 (sulfur capping).

7

7

Elastomeric Pads (Neoprene)

- Thickness: **1/2" ± 1/16"**
- Diameter: Shall not be more than **1/16** inch smaller than the inside diameter of the retaining ring.

Apparatus

8

8

Elastomeric Pads (Neoprene)

- Meet the requirements of Classification ASTM D2000 as follows in Chart A:

| <u>Chart A</u> | |
|----------------|----------------------|
| Shore A | Classification D2000 |
| Durometer | Line Call-Out |
| 50 | M2BC514 |
| 60 | M2BC614 |
| 70 | M2BC714 |

Apparatus

9

9

- The tolerance on Shore A durometer hardness is **± 5 units**.
- Pads will be made of Neoprene.
- **Table 1** provides requirements for use of caps.

10

TABLE 1 Requirements for Use of Neoprene Pads

| Compressive Strength, ^A Mpa (psi) | Shore A Durometer Hardness | Qualification Tests Required | Max Reuses |
|--|----------------------------|------------------------------|------------|
| Less than 10 (1500) | - | Not permitted | - |
| 10 to 40 (1500 to 6000) | 50 | None | 100 |
| 17 to 50 (2500 to 7000) | 60 | None | 100 |
| 28 to 50 (4000 to 7000) | 70 | None | 100 |
| 50 to 80 (7000 to 12000) | 70 | Required | 50 |
| Greater than 80 (12000) | - | Not permitted | - |

^A Compressive strength of concrete at age of testing as specified in contract Documents. For acceptance testing, it is the specified compressive strength f_c

11

Other elastomeric materials that meet the performance requirements of qualification tests are permitted.

Elastomeric pads shall be supplied with the following information:

- Manufacturer’s or Supplier’s name
- Shore A Hardness
- Applicable range of concrete compressive strength from Table 1 or from qualification testing

12

The user shall:

1. Maintain a record indicating the date the pads are placed in service.
2. The pad durometer number.
3. The number of uses to which the pads have been subjected.

Apparatus Elastomeric Pads

13

13

Retainers

- Provide support for and alignment of pads and test specimens.
- Height shall be **1.0± 0.1 inch.**



Apparatus

14

14

The inside diameter of the retaining ring shall not be less than 102% or greater than 107% of the diameter of the specimen.



Surface shall be plane to within 0.002".
Bearing surfaces of retainers shall have no gouges, grooves, or indents larger than 0.001 inch deep or 0.5 inch² in the surface area.

Materials and Apparatus - Retainers

15

15

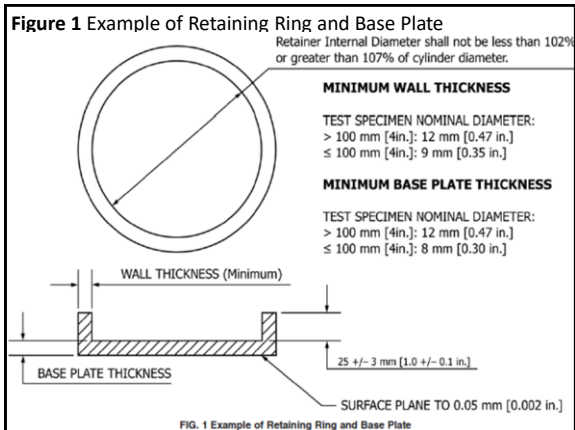

16

TEST SPECIMENS

- Made in accordance with AASHTO T23, or cores obtained in accordance with test method AASHTO T24.
- Depressions under a straight edge measured with a round wire gage across any diameter shall not exceed 0.20 inch.
- If the specimen ends do not meet this tolerance, the specimen shall not be tested unless irregularities are corrected by sawing or grinding.

17

17

Test Specimens

- Unbounded caps are permitted to be used on one or both ends of a test specimen in lieu of cap or caps meeting practice AASHTO T231, provided the caps meet the requirements of ASTM C1231.
- Verify that the pads meet specified requirements:
 - 1/2 inch thick.
 - Diameter no more than 1/16 inch smaller than the inside diameter of the ring.
 - Pad Hardness and Maximum uses meet **Table 1**.
- Insert pad into retainer before placing it on the cylinder.

Note – Some manufacturers recommend dusting the pads and the ends of the specimens with corn starch or talcum powder prior to testing.

18

18

Replace pads that do not meet the dimensional requirements or when they exceed the maximum reuse limits of Table 1.

Complete the load application, testing, calculation, and reporting of results in accordance with test method AASHTO T22.

19

19

SAFETY: Due to sudden release of energy while testing with neoprene pads, it is a good practice to use a wrap for the cylinder, not only for safety reasons but also to protect equipment from damage.



Note: The testing machine may have a cage for testing safety.

20

20

Tips

- Check durometer of pads against requirements for the strength of cylinders being tested.
- Record date pads were placed in service and the number of reuses (100 maximum up to 7000 psi; 50 maximum from 7000 to 12000 psi).
- Examine pads carefully for cracks or splits.
- For strength levels above 7000 psi; qualification of the neoprene caps is required.

21

21

Information only: **MODOT** 

When choosing a capping system at MoDOT;

- Drilled cores are sulfur capped (AASHTO T231).
- 28-day Cylinders typically test in the 4000 to 7000 psi range, in this case we use Neoprene Pads with Shore A Durometer Hardness of 70. No qualification of pads required. (See Table 1)
- In rare occasions when testing older cylinders, day 56 or more, when the compressive strength is over 7,000 psi, MoDOT will use sulfur caps (ASHTO T231).

22

22

See the Appendix for:

**Qualification of Un-bonded Caps
Used for Testing Specimens
Over 7,000 PSI Compressive
Strength**

23

23

ASTM C1231: Use of Unbonded Caps in Determination of Compressive Strength of Hardened Cylindrical Concrete Specimens

PROFICIENCY CHECKLIST

Applicant _____

Employer _____

| Trial # | 1 | 2 |
|---|---|---|
| General | | |
| 1. Pads qualify for use, records kept | | |
| 2. Examined pads for excessive wear or damage | | |
| 3. Examined retainers for grooves, protrusions, or indentations | | |
| 4. Recorded each use of pads | | |
| Unbonded Cap Procedure | | |
| 1. Pads inserted in the retainers before placing on the specimen NOTE: dusting of talc or corn starch if needed on specimen and pads | | |
| 2. Completed load application, testing, calculation and reporting of results in accordance with AASHTO T_22 | | |

PASS PASS

FAIL FAIL

Examiner: _____ Date: _____

AASHTO T 22

Compressive Strength of Cylindrical Concrete Specimens

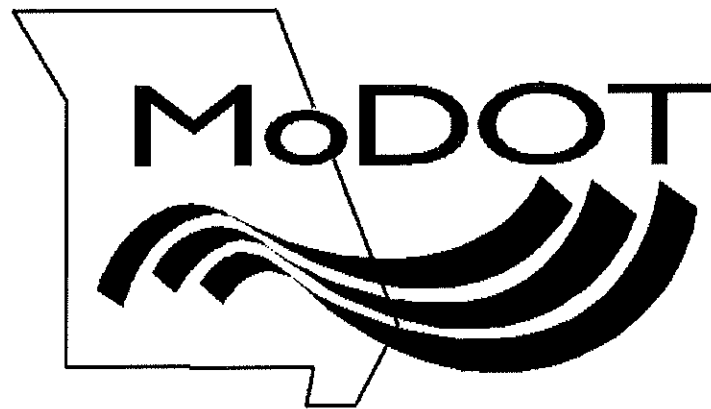



AASHTO T22

Compressive Strength of Cylindrical Concrete Specimens

Revised 09/19/2023

1

MODOT EPG Section 501.1.3.5 Compressive Strength

- Compressive Strength on cylindrical specimens:
 - *Are performed in the field and in the lab.
 - *Will use size 6 x 12" or 4 x 8" cylinders.
 - *To control concrete production.
- All concrete tests, air, slump, as well as specimens for compressive strength should be secured from a single batch of concrete.
- Fill the cylinder molds with fresh concrete per AASHTO T23 or ASTM C31.
- When placing caps on the molds avoid damage to the surface of the concrete and keep the lids on tight to prevent moisture loss.

updated 2

2

TERMINOLOGY

- Bearing block - Steel piece to distribute the load from the testing machine to the specimen.
- Lower bearing block – Steel piece placed under the specimen to distribute the load from the testing machine to the specimen.
- Platen – primary bearing surface of the testing machine.
- Spacer – Steel piece used to elevate the lower bearing block to accommodate test specimens of various heights.
- Upper bearing block – Steel assembly suspended above the specimen that is capable of tilting to bear uniformly on the top of the specimen.

New slide 3

3

SUMMARY

This test method covers determination of compressive strength of cylindrical concrete specimens such as molded cylinders and drilled cores. It is limited to concrete having a unit weight more than 50 lb./ft³.

A compressive axial load is applied to molded cylinders or drilled cores at a rate that is within a prescribed range until failure occurs.

The compressive strength of the specimen is calculated by dividing the maximum load by the cross-sectional area of the specimen.

4

4

SIGNIFICANCE AND USE

This test method may be used to determine compressive strength of cylindrical specimens prepared and cured in accordance with;

AASHTO T22: Compressive Strength Testing

AASHTO T23: Making & Curing Concrete Specimens in the Field.

AASHTO T24: Obtaining & Testing Drilled Cores and Sawed Beams of Concrete

AASHTO T231: Bonded Capping (Sulfur)

ASTM C1231: Neoprene Unbonded Capping

5

5

Strength values obtained will depend on the following:

- A. Size and shape of the specimen
- B. Batching and mixing procedures
- C. Methods of sampling and molding
- D. Age, temperature
- E. Moisture conditions during curing

Significance and Use

6

6

The results of this test may be used as a basis for:

- A. Quality control of concrete
- B. Proportioning
- C. Mixing
- D. Placing operations
- E. Determination of compliance with specification
- F. Control for evaluating effectiveness of admixtures and similar uses

Significance and Use

7

7

APPARATUS

- Load indication shall not exceed 0.1% of full-scale load.
- Applies continuous load without shock.
- Capable of registering loads as specified in the test method.
- Percent error shall not exceed $\pm 1.0\%$ of the indicated load.
- Must be calibrated annually not to exceed 13 months, when relocated, after repairs, or when reason to doubt accuracy.
- The testing machine includes a protective cage to protect the operator from flying particles as the cylinder is broken.

See [Appendix](#) for more information on the testing machine, bearing blocks, Load Indication.

8

8

SPECIMENS

Specimens may be prepared for testing either by AASHTO T231 "Bonded Caps"

OR

ASTM C1231 "Un-bonded Caps"

Testing Compressive Strength



Bonded Cap
Sulfur mortar cap
AASHTO T231



Un-Bonded Cap
Unbonded caps
ASTM C 1231

9

9

Specimens shall not be tested if any individual diameter of a cylinder differs from any other diameter of the same cylinder by more than 2%.

- Ratio range = 0.98 – 1.02%
- Divide two measurements to find the ratio.

Practice Problem:
 Do the individual diameters differ from each other by more than 2%? Determine the ratio:

Diameter 1 = 4.02" Diameter 2 = 4.04"

Ratio: $\frac{4.02}{4.04} = 0.9950 = \text{Pass}$

Range is 0.98 to 1.02

Updated slide

10

The ends of the test specimens shall not depart from perpendicularity to the axis by more than **0.5 degrees**.

For a 6 x 12 inch cylinder
 That's about equivalent to 0.12 inches in 12 inches. (3mm in 300mm) = use a 3mm wrench

For a 4 x 8 inch cylinder
 That's about equivalent to 0.08 inches in 8 inches. (2mm in 200mm.) = use a 2mm wrench

11

11

Perpendicularity Check

- Use a square ruler and a hex wrench to measure.

2mm hex wrench for a (4 x 8)
3mm hex wrench for a (6 x 12)

If the wrench slips through, saw or grind to correct.



New Slide

12

12

- The ends of the specimens that are not plane, **within 0.002 inches**, shall be sawed or ground to meet the 0.002 inch tolerance.

OR

- Capped using bonded capping, AASHTO T231.

OR

- When permitted unbonded capping, ASTM C1231/C1231M.

Specimens

13

13

Average Diameter

- Two measurements taken at right angles at mid-height of specimen to the **nearest 0.01 inch**.
- Average the diameters to determine the cross-sectional area of the test specimen to the **nearest 0.01 inch**.



7.3

14

14

DIAMETER

Readings from Caliper:



Determine the average diameter.

Average Diameter

$$\frac{(4.02 + 4.04)}{2} = 4.03''$$

Updated slide

15

15

Average Diameter, Number to Measure

- If all specimens were made from a single lot of molds that consistently produced the same average diameters within a range of 0.02 inch.

Measure one for each 10 specimens

OR

Measure three per day
(Whichever is greater)

- When average diameters do not fall within the range of 0.02 inch, each specimen tested must be measured individually, and the value used in the calculation of its compressive strength.

16

16

When the diameters are measured at the reduced frequency, the cross-sectional areas of all cylinders tested on that day shall be computed from the average of the diameters of the three or more cylinders representing the group tested that day.

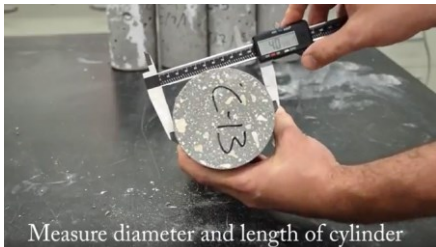

Measure diameter and length of cylinder

17

17

Length-to-Diameter Correction Factor Table

| | | | | |
|---------------|------|------|------|------|
| L/D | 1.75 | 1.50 | 1.25 | 1.00 |
| Factor | 0.98 | 0.96 | 0.93 | 0.87 |

Length/Diameter Ratio:

- Specimens shall be corrected to a L/D ratio of 2.0 when practical.

If specimen L/D ratio is 1.75 or less correct the results obtained by multiplying by the appropriate correction factor listed above.

Interpolate, as necessary.

Calculations

18

18

DENSITY

If measurement of density of the test specimen is to be determined, determine the mass of the specimen before capping.

Remove any surface moisture with a towel and measure the mass of the specimen using a scale that is accurate to within 0.3 percent of the mass being measured.

Measure the length of the specimen to the nearest 0.05 inch at three locations spaced evenly around the circumference.

Compute the average length and recorded to the nearest 1 mm (0.05 inch).

19

19

Density - Methods

- When required, calculate the density of the specimen to the nearest 1lb/ft³.
- Density must be completed prior to capping.

Determine by one of the two methods:

1. Specimen Dimension Method
2. Submerged Weighing Method

$$\text{Density} = \frac{\text{Mass of specimen (lb.)}}{\text{Volume of specimen (ft}^3\text{)}}$$

Volume comes from the average diameter and average length or from weighing the cylinder in air and submerged.

New slide

20

20

Density - Methods

- Submerged Weighing Method -
 - Remove any surface moisture with a towel
 - Determine weight in air
 - Submerge the specimen in water at a temperature of 73.5 ± 3.5°F and determine the weight.



$$P_s = \frac{W \times Y_w}{W - W_s}$$

New slide

21

21

Calculation - Density

$$\pi = 3.14159$$

1. Specimen Dimension Method:

Inch-pound Units

$$P_s = \frac{6912 \times W}{L \times D^2 \times \pi}$$

Ps = specimen density (lb./ft³)
 W = specimen in air (lb.)
 L = average measured length (in.)
 D = average measured diameter (in.)

2. Submerged Weighing Method use:

$$P_s = \frac{W \times Yw}{W - W_s}$$

Ps = specimen density (lb./ft³)
 W = specimen in air (lb.)
 Ws = apparent mass of submerged specimen (lb.)
 Yw = density of water at 73.5°F = 62.27 lb./ft³

New slide

22

When density determination is not required and the length to diameter ratio is less than 1.8 or more than 2.2 measure the length of the specimen to the nearest 0.05 in.



Measure diameter and length of cylinder

23

PROCEDURE

Compression tests of moist-cured specimens shall be completed as soon as practicable after removal from moist storage.



24

24

Test specimens shall be kept moist by any convenient method during the period between removal from moist storage and testing. They shall be tested in the moist condition.



25

25

All test specimens for a given test age shall be broken within the permissible time tolerances prescribed as shown in **Table 2**.

The test age shall start at the beginning of casting specimens, unless MoDOT states otherwise.

| Permissible Time Tolerances | |
|---|-----------------------|
| Test Age | Permissible Tolerance |
| 24 hours | ± 0.5 hours |
| 3 days | ± 2 hours |
| 7 days | ± 6 hours |
| 28 days | ± 20 hours |
| 56 days | ± 40 hours |
| 90 days | ± 2 days |
| For test ages not listed, the test age tolerance is ± 2.0 percent of the specified age. | |

26

26

Placing the Specimen

Wipe clean the bearing faces of the upper and lower-bearing blocks and of the test specimen.

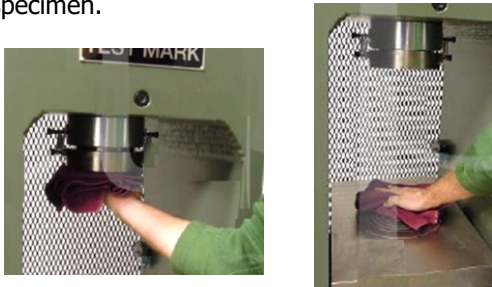

27

27

Place the specimen on the lower bearing block.



28

28

Verification of Alignment

- Place $\leq 10\%$ of anticipated load on specimen.
- Verify the alignment of the specimen.
- Check the axis of the cylinder, that is does not depart from the vertical by more than 0.5° (Equals $1/8''$ in 12").



29

New slide

29



When using unbonded caps (neoprene), place a wrap around the cylinder to control the fracture and for safety.



Center the cylinder under the upper bearing block.

30

30

Initially load specimen.
Gently rotate the upper bearing block as it is brought to bear on the specimen.



31

31

Secure the protective cage.



32

32

Zero Verification and Block Seating – Prior to testing the specimen, verify that the load indicator is set to zero.

In cases where the indicator is not properly set to zero, adjust the indicator.

As the spherically seated block is brought to bear on the specimen, rotate its movable portion gently by hand so that uniform seating is obtained.

NOTE: The technique used to verify and adjust the load indicator to zero will vary depending on the machine manufacturer.

33

33

Reset ultimate load indicator to **zero**.



34

34

Rate of Loading – Apply the load continuously and without shock, except as permitted by ASTM C1231/C1231M, until the specimen has failed.

The load shall be applied at a rate of movement (platen to crosshead measurement) corresponding to a stress rate on the specimen of **35 ± 7 psi/s**. The designated rate of movement shall be maintained at least during the latter half of the anticipated loading phase.

35

35

NOTE: For a screw-driven or displacement-controlled testing machine, preliminary testing will be necessary to establish the required rate of movement to achieve the specified stress rate.

During application of the first half of the anticipated loading phase, a higher rate of loading may be permitted. Apply the higher loading rate in a controlled manner so the specimen is not subjected to shock loading.

Do not adjust the rate of movement (platen to crosshead) as the ultimate load is being approached and the stress rate decreases due to cracking in the specimen)

36

36

NOTE: Machine speed of travel for 4" diameter specimens differs from 6" diameter substantially.

As a rule, use the following load rates:
4" specimens, approx. 450 lbs./force/sec
6" specimens, approx. 1000 lbs./force/sec

Actual ranges:

4"diameter specimens→ 352-528 lbs./force/sec
6"diameter specimens→792-1187 lbs./force/sec

37

37

Apply the compressive load until the load indicator shows that the load is decreasing steadily, and the specimen displays a well-defined fracture pattern.

For a testing machine equipped with a specimen break detector, automatic shutoff of the testing machine is prohibited until the load has dropped to a value that is less than 95percent of the peak load.

When testing with unbonded caps, a corner fracture may occur before the ultimate capacity of the specimen has been reached. Continue compressing the specimen until the user is certain that the ultimate capacity has been reached.

38

38

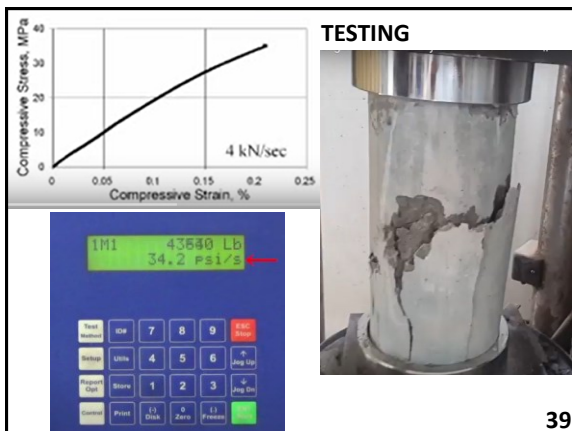

39

Place the cylinder on its side so that the wrap may be removed, and the type of fracture can be determined.



The specimen can now be disposed of in accordance with office practice.

40

40

Record the maximum load carried by the specimen during the test.

Note the type of fracture pattern according to Figure 2.

If the fracture pattern is not one of the typical patterns shown, briefly sketch and describe the fracture.

41

41

Figure 2: A Few Types of Fracture Patterns

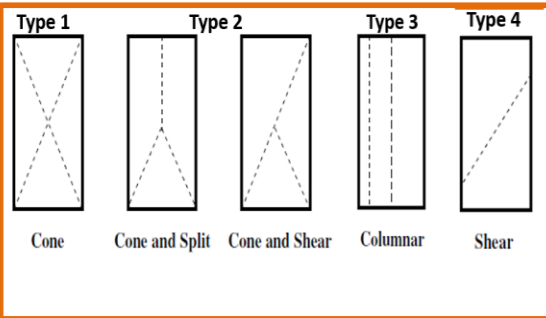

42

42

Example of a Fracture Pattern

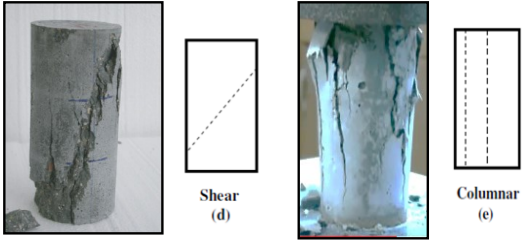

43

43

If the measured strength is lower than expected, examine the fractured concrete and note the following:

- A. Presence of large air voids
- B. Evidence of segregation
- C. Whether fractures pass predominantly around or through the coarse aggregate particles
- D. Verify that end preparations were in accordance with AASHTO T231 or ASTM C1231/C131M.

44

44

CALCULATIONS

Calculate the compressive strength of the specimen by dividing the maximum load carried by the specimen during the test by the average cross-sectional area, report the result to the nearest 10 psi.

$$\frac{L}{A} = \text{Compressive Strength (psi)}$$

L = Ultimate Load in pounds

A = Cross-sectional Area in square inches

45

45

Calculate Out-of-roundness

$$\frac{d1 - d2}{d2} \times 100 = \text{Answer} < 2\% \text{ maximum}$$

| | |
|---|--|
| <p>Example: $d1 = 6.20$ inches $d2 = 6.12$ inches</p> | <p>Note: $d1$ = the larger diameter; $d2$ = the smaller diameter</p> |
|---|--|

$$\frac{(6.20 - 6.12)}{6.12} \times 100 = 1.31 = < 2\%$$

This specimen is not out-of-round; good to test!

46

46

Calculating the Average Diameter

The two diameters ($d1$) and ($d2$) in inches and averaged = (Da).

(d) and Da are reported to the nearest 0.01 inch

$$\frac{d1 + d2}{2} = \text{Average} = Da$$



The diameter average (Da) is used to calculate the cross-sectional area (A).

Calculations

47

47

Calculating the Cross-sectional area of the cylinder

$$\frac{\pi(Da) \times (Da)}{4} = \text{area } (A) \text{ sq.in.}$$

$\pi = 3.14159$

(Da) – reported to the nearest 0.01 inch

(A) – reported to the nearest 0.01 sq. inch

The above equation can be condensed to this:

$$\frac{\pi(Da)^2}{4} = \text{area } (A) \text{ sq.in.}$$

48

48

Calculating the Compressive Strength

Compressive Strength =

$$\frac{L = \text{Ultimate Load in Lbs.}}{A = \text{Average Cross-Sectional Area}}$$

Calculation of compressive strength example:

Example: Ultimate Load at breaking point = 165,220 lbs. Cross-sectional Area = 28.57 in²

$$\frac{165,220}{28.57} = 5,783\text{psi}$$

rounded nearest 10 psi = **5780 psi**

49

When required, calculate the density of the specimen to the nearest kg/m³ (1lb/ft³) as follows:

$$\text{density} = W/V$$

W = mass of specimen, kg (lb.)

V = volume of specimen computed from the average diameter and average length

OR

From weighing the cylinder in air and submerged, m³ (ft³).

Calculations

50

50

REPORTING

- Results shall be reported on standard forms approved for use by MoDOT.
- Identification number.
- Average Measured Diameter (and length if outside the range of 1.8D to 2.2D), in millimeters or inches.
- Cross-sectional area, in square centimeters or square inches.
- Maximum load.
- Compressive strength calculated to the nearest **10 psi**.

51

51

- When two or more companion cylinders tested at the same age are reported, calculate the average compressive strength using the unrounded individual compressive strength values. Report the average compressive strength rounded to the nearest **10 psi**.
- Type of fracture
- Defects in specimen or caps.
- Age of specimen
- When determined, record the density to the nearest 1 lb./ft³ (10kg/m³).
- Serial number of delivery ticket, if available.

Reporting

52

52

Common Errors

- Testing machine loading rate other than **35 ± 7 psi/sec.**
- Not cleaning neoprene pad and controller prior to use.
- Not centering the specimen under the upper bearing block.
- Un-calibrated testing machine.
- Not zeroing the testing machine.

53

53

C.15 Student Problem:

Compressive Strength Example

The diameters of a concrete cylinder specimen are measured as 6.04" and 5.98" and the maximum load sustained in a compression test is 99,000 pounds.

- a) Calculate the average diameter.

(Show your work, formulas used, and circle the reported answer.)

- b) Calculate the cross-sectional area.

- c) Calculate the compressive strength of the cylinder.

Class Problem
Enlarged
are
at the end of
this module.

54

54

Student Problem: Answer

Compressive Strength Example

The diameters of a concrete cylinder specimen are measured as 6.04" and 5.98", and the maximum load sustained in a compression test is 99,000 pounds.

a) Calculate average diameter.

$$\text{Average Diameter} = \frac{D_1 + D_2}{2}$$

$$\text{Average Diameter} = \frac{6.04 + 5.98}{2}$$

$$\text{Average Diameter} = 6.01 \text{ inches}$$

(Show your work, formulas used, and circle the reported answer.)

b) Calculate the cross-sectional area

$$\text{Area} = \frac{\pi D^2}{4}$$

$\pi = 3.14159$

$$\text{Area} = \frac{\pi (6.01)^2}{4}$$

$$\text{Area} = \frac{3.14159 \times 6.01 \times 6.01}{4}$$

$$\text{Area} = 113.47 = 28.37 \text{ sq. inches}$$

c) Calculate the compressive strength of the cylinder.

$$\text{Compressive Strength} = \frac{\text{Maximum Load}}{\text{Ave. Cross-sectional Area}}$$

$$\text{Compressive Strength} = \frac{99,000 \text{ lbs.}}{28.37 \text{ sq. inches}}$$

$$\text{Compressive Strength} = 3,489.60 \text{ psi}$$

$$\text{Report Compressive Strength} = 3490 \text{ psi}$$

Round to the nearest 10 psi

55

Enlarged problem

Enlarged copies are at the end of this module.

Enlarged

55

Extra Problem

- Calculate out of roundness:
 - Diameter 1 = 4.04
 - Diameter 2 = 4.02
 Did it pass roundness?
- Calculate Average Diameter.
- Calculate Cross-sectional Area of the cylinder.
- Calculate the Compressive Strength:
 - Maximum Load = 76,880 lb.

New Slide

56

56

Answer to Extra Problem

Out of roundness calculation:

$$\frac{4.04 - 4.02}{4.02} \times 100 = 0.50\% \quad 0.50 < 2\% = \text{PASS}$$

Average Diameter: $\frac{4.04 + 4.02}{2} = \frac{8.06}{2} = 4.03''$

Cross Sectional Area: $\frac{(3.14159)(4.03)(4.03)}{4} = 12.76 \text{ sq. in.}$

Compressive Strength: $\frac{76,880}{12.76} = 6,025 = 6,030 \text{ psi}$

New Slide

Round to the nearest 10 psi

57

57

Student Problem: Answer

Compressive Strength Example

The diameters of a concrete cylinder specimen are measured as 6.04" and 5.98", and the maximum load sustained in a compression test is 99,000 pounds.

a) Calculate average diameter.

$$\text{Average Diameter} = \frac{D_1 + D_2}{2}$$

$$\text{Average Diameter} = \frac{6.04 + 5.98}{2}$$

$$\text{Average Diameter} = 6.01 \text{ inches}$$

b) Calculate the cross-sectional area

$$\text{Area} = \frac{\pi D^2}{4}$$

$$\pi = 3.14159$$

$$\text{Area} = \frac{\pi (6.01)^2}{4}$$

$$\text{Area} = \frac{3.14159 \times 6.01 \times 6.01}{4}$$

$$\text{Area} = \frac{113.47}{4} = 28.37 \text{ sq. inches}$$

c) Calculate the compressive strength of the cylinder.

$$\text{Compressive Strength} = \frac{\text{Maximum Load}}{\text{Ave. Cross-sectional Area}}$$

$$\text{Compressive Strength} = \frac{99,000 \text{ lbs.}}{28.37 \text{ sq. inches}}$$

$$\text{Compressive Strength} = 3,489.60 \text{ psi}$$

$$\text{Report Compressive Strength} = 3490 \text{ psi}$$

Answers to class
problem

Enlarged copies are at
the end of
this module.

(Show your work, formulas used, and circle the reported answer.)

Enlarged

501.1.3.5 Compressive Strength

Compressive tests are performed both in the field and in the laboratory on cylindrical specimens of concrete, 6 in. diameter and 12 in. tall (6x12) or 4 in. diameter and 8 in. tall (4x8). The Standard Specifications require use of compressive specimens for job control of concrete production.

All concrete for air and slump tests as well as preparation of the specimens should be secured from a single batch of concrete. Air and slump tests should always be made on samples of concrete used for preparation of compressive specimens.

Cylinder forms shall be filled with fresh concrete in accordance with the instructions provided by AASHTO T 23 (ASTM C 31). Care should be taken when placing the caps on the molds to avoid damage to the surface of the concrete. The lids should be kept on tight to prevent moisture loss.

501.1.3.5.1 Curing

Curing of compressive specimens will depend on whether they are for standard cure or field cure.

Standard Cure is defined as 1) specified strength for 28-day testing; 2) Check of mixture proportions or design strength; 3) Quality control (i.e. monitoring mix variability) or 4) Maturity meter curve.

Standard curing involves two phases of curing: initial and final.

Each set of compressive test specimens for standard cure consists of two 6x12 cylinders or three 4x8 cylinders. Standard Cure specimens shall be cured in accordance with AASHTO T23 (ASTM C31) for initial and final curing.

Standard Cure – Initial

If specimens cannot be molded at the place where they will receive initial curing, immediately after finishing move the specimens to an initial curing place for storage. Recommended method for initial curing is keeping the specimen in the plastic mold covered with a plastic lid or place in a damp sand pit for a maximum of 48 hours in a temperature range from 60° F to 80° F and an environment preventing moisture loss.

Standard Cure - Final

Upon completion of initial curing and within 30 minutes of removing the molds, cure specimens with free water maintained on their surfaces at all times at a temperature of 70° F to 77° F using water storage tanks or moisture room per AASHTO M201 (ASTM C511).

Storage Tanks When water tanks are used for final curing the temperature shall be maintained at 70° F to 77° F. Method of recording temperature is required. Transportation of Specimens Specimens may be transported to the Central Laboratory for final curing. To transport, after the initial cure period, the specimen shall be removed from the mold and placed in a plastic bag to maintain free moisture during shipping. Specimens should not be transported to begin final cure until at least 8 hours after final set.

During transporting, use suitable material to prevent damage from jarring and use suitable insulation material during cold weather. Show shipper's name and address on the outside of the box. The box comes with the address of Central Laboratory printed on the side and a preprinted form that provides basic information about the cylinders. If the box does not have the form preprinted, contact the Central Laboratory for copies of the self stick form. SiteManager Sample ID number should be written on the side of cylinders or cylinder molds. Necessary boxes, cardboard liners, polyethylene bags, wire ties and rolls of strapping tape are stock items available by requisition.

Field Curing

Field cure is defined as 1) Opening to traffic strength or staged construction; 2) Comparison with test results of standard cure to in place methods, such as maturity method verification; 3) Adequacy of curing and protection of concrete in the structure, such as cold weather placement or 4) Form removal.

Field curing shall be in accordance with AASHTO T23 (ASTM C 31). Store cylinders in or on the structure as near as practical to the represented concrete. Protect all surfaces of the cylinders from the elements, and ensure a temperature and moisture environment similar to the formed work. To meet these conditions specimens made for the purpose of determining when a structure is capable of being put in service shall be removed from the molds at the time of removal of form work.

Compressive test specimens for field cures may consist of one or more for either 6x12 cylinders 4x8 cylinders. Specimens prepared to determine when forms may be removed will be cured as described in above except for bridge decks or heated concrete. Specimens representing bridge decks are to be cured on the deck under wet mats until the cylinders are to be broken or wet curing is discontinued. If cylinders remain after wet curing has ended, they shall be cured in plastic molds under field conditions until they are to be broken.

Specimens representing heated concrete are to be left in the enclosure subject to the same protection as concrete they represent until they are to be broken. Cylinders should be left in molds and covered with wet burlap for 48 hours. If cylinders remain after the heating period has ended they shall be cured in plastic molds under field conditions until they are to be broken.

Curing of bridge decks shall be in accordance with Standard Specification 704, wet curing shall be maintained for 7 days and until the concrete has reached a minimum of 3000 psi

Test Procedures

A calibrated testing machine must be used by a certified technician. The SiteManager sample record must be completed documenting the testing. Testing is to be done in the hydraulically operated compressive testing machine. If there is doubt as to the 28-day strength of the cylinder, relative to the working capability of the available testing machine, send the cylinders to the Central Laboratory. All specimens are to be loaded to failure.

All cylinders are to be tested using a neoprene cap in a steel extrusion controller placed on each end of the cylinder. The neoprene caps have 6 1/8 in. diameters and are 1/2 in. thick. The caps are made from

neoprene and no substitution of material or cap is to be made. A 50 durometer neoprene cap is used for concrete with a cement factor of less than 7.5 sacks per yard. Otherwise, a 60 durometer neoprene cap is used. The caps should be replaced if worn or after a maximum of 100 cylinder breaks.

The steel extrusion controller's outside bearing surface is to be maintained free of gouges, dents or protrusions greater than 0.03125 in. or 0.0625 sq. in. surface area. The inside bearing surface is to be maintained to within 0.002 in. of plane.

Care should be taken when molding the specimen since irregularities can result in poor test results. Specimens should be tested using neoprene pads per ASTM C1231 or capped in accordance to AASHTO T231.

Projections on the ends of test specimens should not be higher than 0.20 inches, and corrected as necessary before testing.

Neither end of the concrete cylinder is to depart from perpendicularity to the axis of more than 0.5 degrees or 0.12" in 12" (0.08" in 8"). Neither end of the cylinder is to be marked by scratching in the date, cylinder number, etc. Cylinders not meeting these conditions shall not be tested unless the irregularity is first corrected.

Neither end of the cylinder is to be marked by scratching in the date, cylinder number, etc. Cylinders not meeting these conditions shall not be tested unless the irregularity is first corrected.

Neither end of the cylinder is to be marked by scratching in the date, cylinder number, etc. Cylinders not meeting these conditions shall not be tested unless the irregularity is first corrected.

A sufficient amount of ordinary corn starch is used to completely fill any void between the edge of the neoprene pad and the steel extrusion controller and to lubricate the face of the neoprene pad that contacts the concrete cylinder. In lieu of corn starch, Pledge spray wax has been used with good results.

The same surface of the neoprene cap is to bear on the concrete cylinder for all tests performed with that cap.

Place a steel extrusion controller containing a neoprene cap on the top and bottom surface of the concrete surface. As the upper bearing block is lowered, carefully align the cylinder's axis with the center of thrust of the upper block. The upper block should be carefully seated to obtain uniform bearing. No loose particles are allowed between the concrete cylinder and the neoprene caps or between the bearing surfaces of the extrusion controllers and the bearing surfaces of the test machine.

Concrete cylinders tested with neoprene caps rupture more intensely than comparable cylinders tested with sulfur-mortar caps. The test machine is to be equipped with a protective cage to protect the operator from flying fragments.

Once the cylinder is carefully seated, load shall be carefully and uniformly applied. The last half of the anticipated maximum load must be applied at a constant rate which falls within the range of 35 ± 7 (that is, 28 to 42) psi per second or between 352 and 528 pounds force per second for 4 in. diameter cylinders

Category :501 Concrete – Engineering Policy Guide

and between 792 and 1187 pounds force per second for 6 in. diameter cylinders on the gauge dial. The first half of load may be applied at a faster rate. Load is to be increased until the specimen fails. Needle travel or digital load readout will usually slow, or even stop, just before visible failure. The maximum distance of ram movement is 2 inches.

On digital readout machines, total load is captured automatically. On dial readout machines, although the red needle is supposed to indicate total load, it should be watched carefully to be sure it does not spring back at failure of the specimen. As soon as the specimen fails, the pressure should be released allowing the upper block to return to the unloaded position.

All test data shall be recorded in SiteManager. Results of the tests are to be reported to the nearest 10 psi.

AASHTO T_22: Compressive Strength of Cylindrical Concrete Test Specimens

PROFICIENCY CHECKLIST

Applicant _____

Employer _____

| | 1 | 2 |
|--|---|---|
| Trial # | | |
| Specimen Preparation | | |
| 1. Reduced to Length /Diameter ratio of 2 to 1 and length of specimen reported to nearest 0.01" | | |
| 2. Ends checked for perpendicularity to axis does not exceed 0.5° | | |
| 3. No projections exceeded 0.2 inch | | |
| 4. Diameter of the ends did not depart more than 0.1" from the mean diameter of the core | | |
| 5. Mass of the specimen reported to the nearest 0.1 lbs. | | |
| Bonded or Un-bonded Caps | | |
| 1. Follow procedure for Bonded caps in AASHTO T 231 | | |
| 2. Follow procedure for Unbonded Caps in ASTM C1231 | | |
| Compression Testing | | |
| 1. Equipment verification within 13 months | | |
| 2. Two diameter measurements taken at the mid-section of the specimen, measured to 0.01" , reported average to 0.01" | | |
| 3. Specimens kept moist | | |
| 4. Lower and upper bearing surfaces wiped clean | | |
| 5. Axis of the specimen centered under the upper bearing block | | |
| 6. Zero setting checked prior to testing and adjusted when necessary | | |
| 7. Spherical block rotated prior to contacting the specimen | | |
| 8. Load applied continuously and without shock at the specified rate of 35 ± 7 psi/s | | |
| 9. No rate adjustment made while the cylinder was yielding | | |
| 10. The maximum load recorded | | |
| 11. Cylinders tested to failure and the type of fracture determined and recorded | | |
| 12. Specimen tested within the time tolerance | | |
| 13. Calculation and reporting of results in accordance with AASHTO T_22 | | |

PASS PASS

FAIL FAIL

Examiner: _____ Date: _____

AASHTO T 97

Flexural Strength of Concrete

(Using Simple Beam with Third-Point Loading)

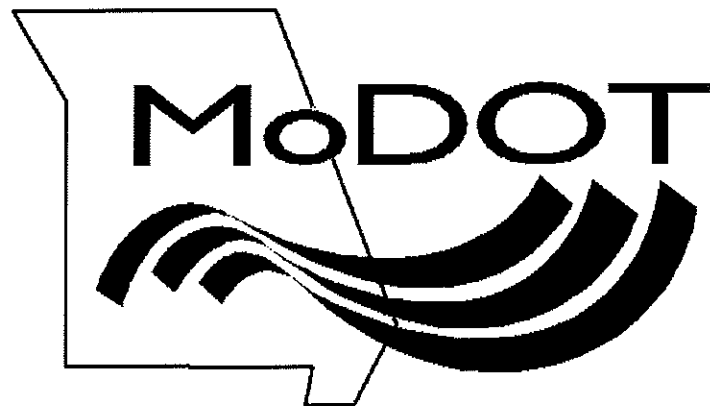

AASHTO T 97



Flexural Strength of Concrete

(Using Simple Beam with Third-Point Loading)

Rev 08/16/2023

1

SCOPE

- This test method covers determination of the flexural strength of concrete by the use of a simple beam with third-point loading.

Third-point loading

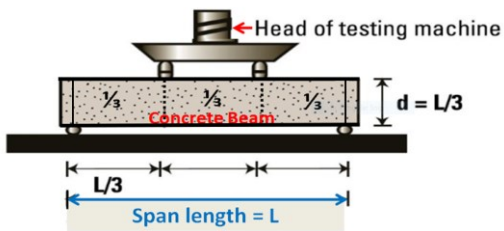

2

2

TERMINOLOGY

Loading Block:
Used to apply a force to the beam.

Support Block:
Used to support the beam.

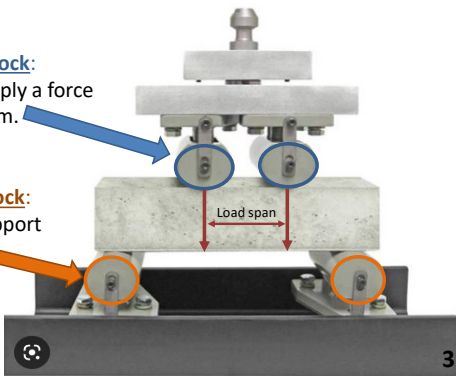

3

3

SIGNIFICANCE AND USE

- This test method is used to determine the flexural strength of specimens prepared and cured in accordance with AASHTO Methods T 23, T 24M/T 24, or R 39.
- Results are calculated and reported as the **Modulus Of Rupture (MOR)**.
- Strength will vary where there are differences in specimen size, preparation, moisture conditioning, curing, or where the beam has been molded or sawed to size.

4

4

- The results are used to determine compliance with specifications or as a basis for proportioning, mixing, and placement operations.
- The results are used in testing concrete for construction of slabs and pavements.

Terminology

- **Flexural Strength:** Flexural strength of a material is defined as the maximum bending stress that can be applied to that material before it yields.
- **Span Length:** Distance between lines of support, or reaction, for the beam specimen; equal to three times the nominal depth of the beam.

Significance and Use and terminology

updated Slide

5

5

APPARATUS

- Shall conform to practice ASTM E4.

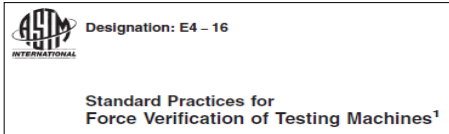

- Must be capable of applying a load at uniform rate without shock or interruption.
- Capable of maintaining span length and distances between load-applying blocks constant within ± 0.05 inches.

6

6

- The ratio of the horizontal distance between the point of application of the load and the point of application of the nearest reaction to the depth of the beam shall be 1.0 ± 0.03
- The load-applying and support blocks should not be more than $2\frac{1}{2}$ inches high and should extend entirely across or beyond the full width of the specimen.
- The load-applying and support blocks should be maintained in a vertical position and in contact with the rod or ball by means of spring-loaded screws that hold them in contact with the pivot rod or ball.

Apparatus

7

7

Concrete Beam Testing Video:



8

8

TESTING

- Sides shall be at right angles to the top with smooth surfaces.
- All surfaces shall be smooth and free of scars, indentations, holes, or inscribed identification marks.
- **Molded Beams** are 20 inches in length.
- **Sawed Beams** must be at least 21 inches in length.

$\frac{1}{3} = 6$ inches

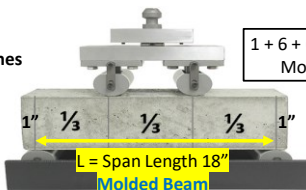

$1 + 6 + 6 + 6 + 1 = 20''$
Molded Beam

L = Span Length 18"
Molded Beam

9

9

PROCEDURE

- Specimens shall be kept moist during the period between removal from moist storage and testing.

NOTE: Surface drying of the specimen results in a reduction in the measured flexural strength.

NOTE: Methods for keeping the specimen moist include wrapping in moist fabric or matting or keeping specimens under lime water in containers near the flexural testing machine until time of testing.

10

10

Beam Tolerances for specimen ages:

| Test Age | Permissible Tolerance |
|----------|-----------------------|
| 24 hours | ± 0.5 hours |
| 3 days | ± 2 hours |
| 7 days | ± 6 hours |
| 28 days | ± 20 hours |
| 90 days | ± 2 days |

New Slide

11

11

- Turn a **molded beam** on its side for testing and center it on the support blocks.
- When using a **sawed beam**, position it so that the tension face corresponds to the top or bottom of the specimen as cut from the parent material.

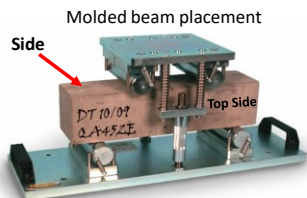

Procedure

12

12

- Center the loading system in relation to the applied force.
- Bring the load-applying blocks in contact with the surface of the specimen at the third points and apply a load of between 3 to 6 percent of the estimated ultimate load.



Procedure

13

13

- Use leaf-type feeler gauges 0.10mm (0.004") and 0.40mm (0.015") to determine whether any gap between the specimen and the load-applying or support blocks is greater or lesser than each of the gauges over a length of 25mm (1") or more.

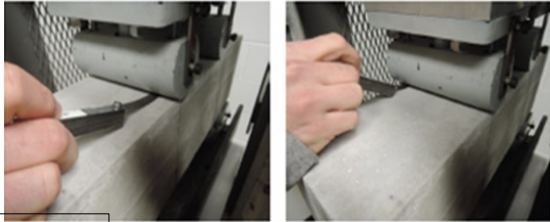

Procedure

Image is from CTPP Arkansas

14

14

- Grind, cap, or use leather shims on the specimen contact surface to eliminate any gap in excess of 0.10mm (0.004") in width.
 - Shims
 - Uniform to 6.4 mm (¼ inch) thickness
 - 25 to 50 mm (1.0 to 2.0 inches) wide
 - Shall extend across the full width of specimen
 - Gaps in excess of 0.40mm (0.015") shall be eliminated only by capping or grinding.

Procedure

15

15

- Load specimen continuously without shock until break occurs.
- Apply at a rate that constantly increases the maximum stress on the tension face between 0.9 and 1.2 Mpa/min (125-175 psi/min) until rupture
- Loading rate is calculated using the following equation:

$$r = \frac{Sbd^2}{L}$$

r = loading rate (lb./min)
 S = rate of increase in max stress on tension face (psi/min)
 b = average width (assume 6.00")
 d = average depth (assume 6.00")
 L = span length (assume 18.00")

Procedure

16

16

Measurement of Specimens After Testing:

1. To determine the dimensions of the specimen cross-section for use in calculating modulus of rupture;
 - Take measurements across one of the fractured faces after testing.
 - Take the width and the depth measurements with the specimen as oriented for testing.
 - For each dimension take one measurement at each edge and one at the center of the cross-section.

16

17

2. Use the three measurements for each direction to determine the average width and the average depth.
3. Take all measurements to the nearest 1.3mm (0.05").

NOTE: If the fracture occurs at a capped section, include the cap thickness in the measurement.

Measurements

18

18

Measuring of Specimens After Testing:

This fracture is in the middle third.

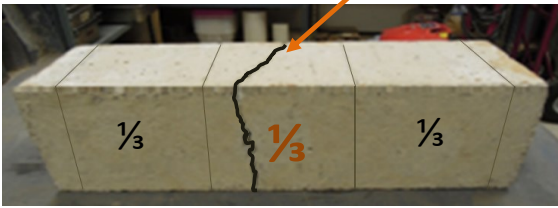

Procedure - Measuring

19

19

Measurement of specimen after testing

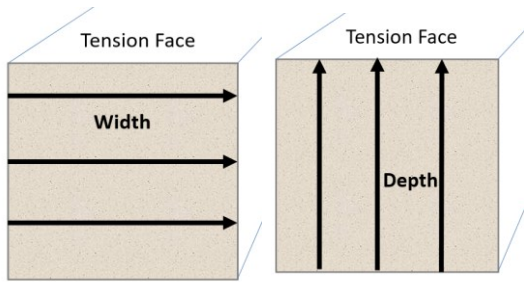

New Slide

20

20

- Within the middle third
– 3 measurements width

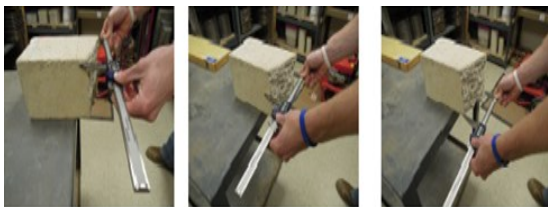

Procedure - Measuring

21

21

- Within the middle third
– 3 measurements depth



Procedure - Measuring

22

22

CALCULATION

- Fracture in the middle third:

$$R = \frac{P \times L}{b \times d^2}$$

R = Modulus of rupture (psi)

P = Maximum applied load

L = Span length (inches)

b = Average of 3 measurements for width (nearest 0.05")

d = Average of 3 measurements for depth (nearest 0.05")

Calculate to the nearest 5 psi

23

23

PRACTICE PROBLEM #1

- Fracture in the middle third:

$$R = \frac{P \times L}{b \times d^2}$$

Calculate the modulus of Rupture for the following beam, the break was in the middle third:

P = 8675

L = 18 inches

b = 6.05" is the average of 3 width measurements

d = 6.00" is the average of 3 depth measurements

Report to the nearest 5 psi

24

24

ANSWER

P = 8675
 L = 18 inches
 b = width average = 6.05"
 d = depth average = 6.00"

$$R = \frac{PL}{b \times d^2} = \frac{(8675)(18)}{(6.05)(6.00)(6.00)} = \frac{156,150}{217.4} = 718.26$$

Report to nearest 5 **R = 720 psi**

Create a scale of 5: 715.....718.....720 2 away is closest ans. = 720

25

25

PRACTICE PROBLEM #2

Calculate the modulus of rupture for the following beam, the break was in the middle third of the span length. Given the following information:

P = 9,389
 L = 18 inches
 b = Average width = 6.00
 d = Average depth = 5.95

Answer R = 795 psi

26

26

Outside the middle third but within 5% of span length.

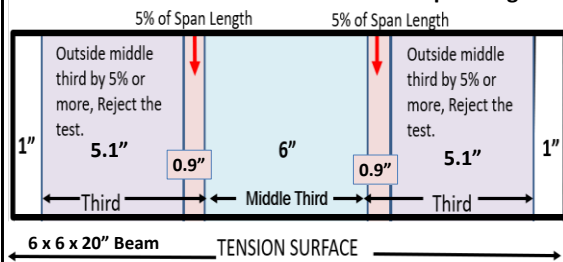

If a fracture occurs outside the middle third but within 5% of span length, use the calculation
 On the next slide to calculate R = Modulus of Rupture in psi.
 $18 \times 0.05 = 0.9"$ $5\% = 0.9"$

New Slide

27

27

Calculation

Fracture outside middle third but not more than 5% of span length:

$$R = \frac{3 \times P \times a}{b \times d^2}$$

P = maximum applied load

a = average distance between the line of fracture and the nearest support measured on the tension surface of the beam, (inches 0.1")

b = average width in inches, nearest 0.05"

d = average depth in inches, nearest 0.05"

Calculate to the nearest 5 psi 28

28

Fracture outside the middle third, but within 5% of the span length:

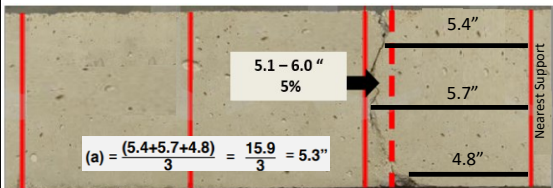

Take 3 measurements for width and 3 measurements for depth
And for "a" in the calculation: Measure the distance between the line of fracture and the nearest support measured on the tension surface of the beam, in inches.

Procedure - Measuring

New Slide

29

29

Practice - Problem - Outside Middle Third ≤ 5%

Calculate the modulus that ruptured ≤ 5% outside the middle third of the span length:

Depth of beam = 6.05" = d

Width of beam = 6.10" = b

Load at break = 8210 lbf = P

Distance of fracture from nearest support = 5.3" = a

calculations: $R = \frac{3 \times P \times a}{b \times d^2}$ Ans = psi

Report to the nearest 5psi 30

30

ANSWER

Calculate the Modulus = R

$$\text{English, } R = \frac{3 \times 8210 \times 5.3}{6.10 \times 6.05 \times 6.05} = 586.79 \text{ psi}$$

Report "R" = To the nearest 5 psi = 585 psi

Scale of 5 = 585 586 590
1 3
1 away, makes 585 closest

Updated slide

31

31

CALCULATION

Fracture outside middle third and more than 5% of span length:

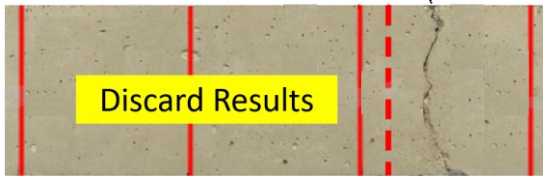

32

32

REPORTING

- Identification number
- Average width to the nearest 1mm (0.05 inch)
- Average depth to the nearest 1mm (0.05 inch)
- Span length in millimeters (inches)
- Maximum applied load in newtons (pounds-force)
- Modulus of Rupture calculated to the nearest 0.05 Mpa (5psi)
- Curing history and apparent moisture condition of the specimens at the time of test
- If specimens were capped, ground, or if leather shims were used
- If specimens were sawed or molded and any defects
- Age of specimen and size

33

33



**AASHTO T 97: Test for Flexural Strength of Concrete
(Using Simple Beam with Third-Point Loading)**

PROFICIENCY CHECKLIST

Applicant _____

Employer _____

| | Trial # | 1 | 2 |
|--|---------|---|---|
| General | | | |
| 1. Apparatus verified per ASTM E4 | | | |
| 2. Test specimens prepared and cured in accordance with AASHTO T 23, and T 24 | | | |
| 3. Apparatus, applied a load and support blocks were in a vertical position and in contact with the rod or ball | | | |
| Procedure | | | |
| 1. Moist-cured specimens tested soon after removal from moist storage | | | |
| 2. <u>Molded specimens:</u> Turned on its side with respect to position as molded and centered on support blocks <u>Sawed specimens:</u> Positioned so that the tension face corresponds to the top or bottom as cut from the parent material | | | |
| 3. Centered the loading system | | | |
| 4. Load blocks were in contact with surface of specimen at third points | | | |
| 5. Load applied between 3% and 6 % of the estimated ultimate load | | | |
| 6. Used a feeler gauge to check for gaps between the specimen and the load applied | | | |
| 7. <u>Eliminated gaps in excess of 0.10mm (0.004 inches) width across the entire specimen:</u> grind, cap or used leather shims on the specimen contact surface | | | |
| 8. <u>Eliminated gaps in excess of 0.38mm (0.015 inches) only by capping or grinding</u> | | | |
| 9. Loaded the specimen continuously and without shock | | | |
| 10. Load applied at a constant rate to the breaking point | | | |
| 11. Load applied at a rate that increases the maximum stress between 0.9 and 1.2 MPa/min (125 and 175 psi), until rupture | | | |
| 12. Specimen measured after testing to the nearest 1.3 mm (0.05 in) | | | |
| 13. Calculations: Fracture in middle third used: $R = PL/bd^2$ Fracture in middle third of the span length by not more than 5% used $R = 3Pa/bd^2$ Fracture in outside of the middle third by more than 5% Test results discarded | | | |

PASS PASS

FAIL FAIL

Examiner: _____ Date: _____



Appendix



Capping Cylindrical Concrete Specimens

Capping Equipment

The capping plates, alignment device, and capping material will be verified as meeting the specified requirements.

– Capping plates

- Sulfur caps shall be formed against similar metal or stone plates.
- Plates shall be at least 25mm (1") greater in diameter than the test specimen and the working surfaces shall not depart from a plane by more than 0.05mm (0.002") in 150mm (6"). The surface roughness of newly finished metal plates shall not exceed that set forth in Table 4 of the American National Standard for surface Texture (ANSI B46.1) or 0.003mm (125µin.) for any type of surface and direction of lay.
- The surface when new shall be free of gorges, grooves, or indentations beyond those caused by the finishing operation.
- Metal plates that have been in use shall be free of gouges, grooves, or indentations greater than 0.25mm (0.010 in.) deep or greater than 32mm² (0.05in.²) in surface area.
- AASHTO T231 4.1

• Capping Plates (4.1)

- Plates shall be at least 1" greater in diameter than specimen



- **Capping Plates (4.1)**

- Working surface shall not depart from plane by more than 0.002" in 6"



- Surface shall be free from gouges, grooves, and indentations
 - Greater than 0.010 in. deep, 0.05 in² surface area



- **Axis of the alignment device and the surface of a capping plate**
 - **Perpendicular to 0.5°**
 - **Note 2: 1 mm in 100 mm [1/8 in. in 12 in.]**
 - **Located so that no cap off-centered by more than 1/16"**



– Alignment Devices

- Suitable alignment devices such as guide bars or bull's-eye levels shall be used in conjunction with capping plates to ensure that no single cap will depart from the perpendicularity of the cylindrical specimen by more than 0.5 degrees (equal to a slope of approximately 1mm in 100mm (1/4" in 12"))
- The same requirement is applicable to the relationship between the axis of the alignment device and the surface of a capping plate when guide bars are used. In addition, the location of each bar with respect to its plate must be such that no cap will be off-centered on a test specimen by more than 1.6mm (0.06").

– Melting Pots for Sulfur Mortars

- Pots used for melting sulfur mortars shall be equipped with automatic temperature controls and shall be made of metal or lined with a material that is nonreactive with molten sulfur.
- Melting pots equipped with peripheral heating will ensure against accidents during reheating of cooled sulfur mixtures that have a crusted-over surface.

- Melting pots without peripheral heating, a large metal ladle that contacts the bottom of the pot and projects above the surface of the fluid sulfur mix as it cools, can help prevent pressure buildup under the hardened surface crust on subsequent reheating.
- Sulfur melting posts should be used under a hood to exhaust the fumes to outdoors. If sulfur catches fire, put a lid on it to snuff it out.

• Melting Pots for Sulfur Mortar (4.3)

- Equipped with automatic temperature controls
- Metal or lined with material that is not reactive with molten sulfur
- Use in a hood to exhaust fumes
- Open flame dangerous: flash point of sulfur is 405°F



- The strength of the capping material and the thickness of the caps shall conform to the Table below:

| Cylinder Compressive Strength MPa (psi) | Minimum Strength of Capping Material | Maximum Average Thickness of Cap | Maximum Thickness Any Part of Cap |
|---|--|----------------------------------|-----------------------------------|
| 500 to 7,000 psi (3.5 to 50 MPa) | 5,000 psi (35 MPa) or cylinder strength, whichever is greater | 0.25 in (6 mm) | 0.31 in (8 mm) |
| greater than 7,000 psi (50 MPa) | Compressive strength not less than cylinder strength, except as provided in Section 5.1.1. | 0.125 in (3 mm) | 0.20 in (5 mm) |

Compressive Strength and Maximum Thickness of Capping Materials
Table 1

Any materials, except neat cement paste, used to test concretes with strengths greater than 7000 psi, that has a strength less than the cylinder strength, shall provide the following documentation (5.1.1)

- Average strength of 15 cylinders capped with material not less than 98% of companion cylinders capped with neat cement or ground plane to within 0.002.
 - Standard deviation of strength should not be greater than 1.57 times standard deviation of reference cylinders
 - Cap thicknesses were met
 - Hardening time
 - Compressive strength of 2 in. cubes
- If sulfur mortar, high strength gypsum plaster, and other materials except neat cement paste are to be used to test concrete with a strength greater than 50MPa (7000psi), the manufacturer or the user of the material must provide documentation:
- That the average strength of 15 cylinders capped with the materials is not less than 98% of the average strength of 15 companion cylinders capped with neat cement paste or 15 cylinders ground plane to within 0.05 mm (0.002in.)
 - That the standard deviation of the strengths of the capped cylinders is not greater than 1.57 times that of the standard deviation of the reference cylinders;
- That the cap thickness requirements were met in the qualification tests; and of the hardening time of the caps used in the qualification tests.
- Additionally, the qualification test report must include the compressive strength of 50-mm (2in.) cubes of the material qualified and of neat cement paste cubes, if used. Capping materials conforming to these requirements are permitted to be used for cylinders with strengths up to 20% greater than the concrete tested in these qualification tests. The manufacturer must re-qualify loss of material manufactured on an annual basis or whenever there is a change in the formulation of the raw materials. The user of the material must retain a copy of the qualification results, and the dates of manufacture of material qualified and of the material currently being used. See Table 2

Note-Manufacturer: Testing Supplies Co.

Capping Material: Super Strong AAA-Sulfur mortar

Lot: 12a45 Date Tested: 11/3/98

Signed by: _____
(Testing Agency and Responsible Official)

| Item | Capping Material | Control Cylinders | Ratio | Criteria | Pass/Fail |
|---|-----------------------------|-----------------------------|----------------|--|--------------|
| Concrete Cylinder Test Data Type of Capping Material | Sulfur | Ground | | | |
| Average Concrete Strength, MPa (psi) Standard Deviation MPa (psi) | 76.2 (11,061) 2.59 (376) | 75.9 (11,008) 1.72 (250) | 1.005 1.504 | >0.98 X _c ≤1.57 C | Pass Pass |
| Number of cylinders tested | 15 | 15 | | | |
| Cap age when cylinders tested | 7 days | n/a | | | |
| Capping Material Test Data Average cap thickness mm (in) | 2.8 (0.11) | n/a | | | |
| Compressive strength of 50 mm (2 in) cubes, MPa (psi) | 91 (12,195) | | | | |
| Cube age when tested | 7 days | | | | |
| Maximum concrete strength qualified, MPa (psi) aNominally a specified strength of 75 MPa (11,000 psi) and perhaps somewhat higher. | | | | 1.2 Av. Str = 91.5 (13,273) ^a | |

Sample Report of Qualifications of a Capping Material
Table 2

- The compressive strength of capping materials shall be determined by testing 50-mm (2in.) cubes following the procedure described in T106M/T106. Except for sulfur mortars, molding procedures shall be as in T106M/T106 unless other procedures are required to eliminate large entrapped air voids.
- The strength of the capping material shall be determined on receipt of a new lot and at intervals not exceeding 3 months. If a given lot of the capping material fails to conform to the strength requirements, it shall not be used, and strength tests of the replacement material shall be made weekly until four consecutive determinations conform to specification requirements.

– **Neat Hydraulic Cement Paste:**

- Make the qualification test of the neat hydraulic paste prior to use for capping to establish the effects of water/cement ratio and age on compressive strength of 50-mm (2in.) cubes.
- Mix the neat cement paste to the desired consistency at a water/cement ratio equal to or less than that required to produce the required strength, generally 2 to 4 hours before the paste is to be used. Remix as necessary to maintain acceptable consistency. Some re-tempering of the paste is acceptable if the required water/cement ratios of 0.32 to 0.36 by mass for Type I and Type II cements and 0.35 to 0.39 by mass for Type III cements.

– **High-Strength Gypsum Cement Paste:**

- No fillers or extenders may be added to neat high-strength gypsum cement paste subsequent to the manufacture of the cement. Qualification tests shall be made to determine the effects of water/cement ratio and age on the compressive strength 50-mm (2in) cubes. Retarders may be used to extend working time, but their effects on required water/cement ratio and strength must be determined.
- Mix the neat gypsum cement paste at the desired water/cement ratio and use it promptly because it sets rapidly.

– **Determination of Compressive Strength**

- Prepare test specimens using a cube mold and base plate conforming to the requirements of T106M/T106 and a metal cover plate conforming in principle to the design shown in Figure 1.
- Bring the various parts of the apparatus to a temperature of 20-30°C (68 - 86°F), lightly coat the surfaces that will be in contact with the sulfur mortar with mineral oil and assemble near the melting pot. Bring the temperature of the molten sulfur mortar in the pot within a range of 129 to 143°C (265 to 290°F), stir thoroughly, and begin casting cubes. Using a ladle or other suitable pouring device, quickly fill each of the three compartments until the molten material reaches the top of the filling hole. Allow sufficient time for maximum shrinkage, due to cooling, and solidification to occur (approximately 15min) and refill each hole with molten material. After solidification is complete, remove the cubes from the mold without breaking off the knob formed by the filling hole in the cover plate. Remove oil, sharp edges, and fins from the cubes and check the planeness of the bearing surfaces in the manner described in T106M/T106. After storage at room temperature to the desired age, but not less than 2 hours, test cubes in compression following the procedure described in T106M/T106 and calculate the compressive strength in Mpa (psi).

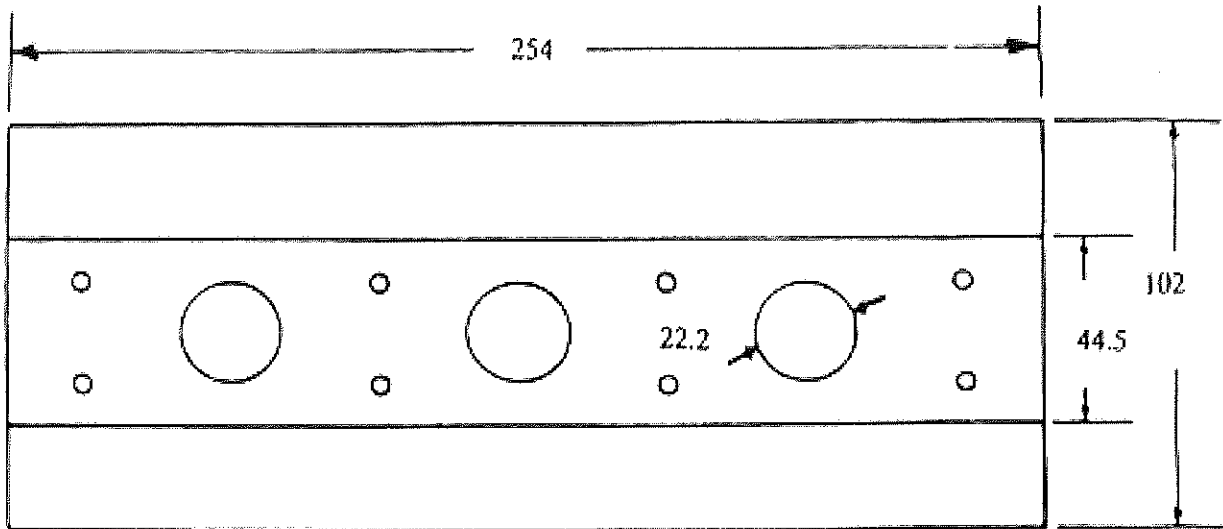

COVER PLATE - Plan View

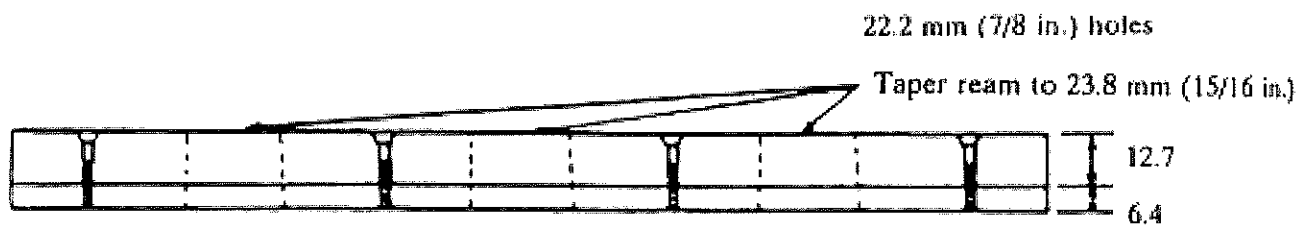

COVER PLATE - Front View

Note: All dimensions are in millimeters unless otherwise indicated.

Dimensional Equivalents

| | | | | | | |
|-----|-----|------|------|-------|-----|-----|
| mm | 6.4 | 12.7 | 22.2 | 44.5 | 102 | 254 |
| in. | 1/4 | 1/2 | 7/8 | 1 3/4 | 4 | 10 |

FIGURE 1 Sketch of Cover for 50-mm (2-in.) Cube Mold

| Dimensional Equivalents | | | | | | | |
|--|-----|------|------|-------|-----|-----|--|
| mm | 6.4 | 12.7 | 22.2 | 44.5 | 100 | 250 | |
| in | 1/4 | 1/2 | 3/4 | 1 1/4 | 4 | 10 | |
| Notes: | | | | | | | |
| All dimensions shown in millimeters unless otherwise noted. Sketch of Cover for 2 in (50 mm) Cube Mold | | | | | | | |

- **Make qualification tests on 2 inch cubes**
 - To determine effect of w/c ratio and age
- **Mix to desired consistency generally 2 to 4 hours before paste is to be used**



- **Make qualification tests on 2 inch cubes**
 - To determine effect of w/c ratio and age
- **Mix to desired consistency and use promptly**



- **Sulfur Mortar (5.4)**

- Harden 2 hours – strengths less than 5000 psi
- Harden 16 hours – strengths 5000 psi or greater



- **Qualification test**

- Bring apparatus to temperature of 68 to 86°F
- Lightly coat surfaces with mineral oil



- **Sulfur Mortar (5.4)**

- **Qualification test**

- **Bring mortar temperature to 265 to 290°F**



- **Sulfur Mortar (5.4)**

- **Stir sulfur**



- **Fill to top**
- **Allow for shrinkage**
- **Refill with sulfur**



- **Allow to solidify**
- **Remove from molds without breaking knob**

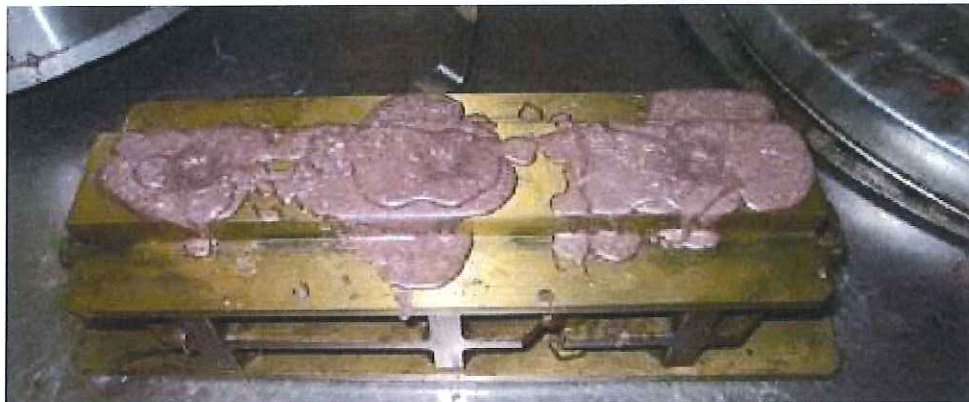

- **Remove oil, sharp edges, and fins**
- **Check planeness**
- **Test cubes in compression – (ASTM C109)**
- **Calculate compressive strength**



Determining compressive strength:

- For high-strength gypsum plaster, mold specimens as required by AASHTO T 106. Conduct strength tests according to steps 7 through 9 for sulfur mortar (see sulfur mortar procedure below).
- For sulfur mortar, mold cubes and conduct strength testing as follows:
 1. Apply a light coat of mineral oil to the cube mold and cover plate. Assemble the mold and attach the cover plate.
 2. Bring the assembled apparatus to a temperature of 68 to 86°F. Place the apparatus near the capping area.
 3. Bring the temperature of the molten sulfur mortar in the pot to a range of 265 to 290°F, stir thoroughly, and begin casting cubes.
 4. Using a ladle, pour the molten sulfur mortar into the filling holes of the cover plate until level with the top of the filling holes.
 5. Allow the material to cool such that maximum shrinkage occurs (usually about 15 minutes), then refill with molten sulfur mortar to the top of the filling holes.
 6. After cubes have solidified, remove the mold without breaking off knobs formed by filling holes and remove oil, sharp edges, and fins.
 7. After the required curing period at room temperature (not less than 2 hours), check planeness of bearing surfaces, and measure dimensions. Calculate cross-sectional area.
 8. Test for compressive strength according to AASHTO T 106, applying the test load at a rate of 200 to 400 pounds/second.
 9. Calculate compressive strength by dividing the total load by the cross-sectional area.

– **CAPPING PROCEDURES**

– **Capping with High-Strength Gypsum Cement Paste or Neat Hydraulic cement Paste:**

- Mix the paste as described above. Do not exceed the water-cement ratio determined in qualification tests. Form the caps as described to achieve the alignment required. Generally, capping plates may be removed within 45 min with high strength gypsum paste and after 12 hours with neat hydraulic cement paste, without visibly damaging the cap.
- Type I neat cement caps generally require at least 6 days to develop acceptable strength and Type III neat cement caps at least 2 days. Dry concrete specimens will absorb water from freshly mixed neat cement paste and produce unsatisfactory caps. Neat cement paste caps will shrink and crack on drying and therefore should be used only for specimens that are to be moist-cured continuously until time of testing.

Specimens with gypsum plaster caps shall not be immersed in water and shall not be stored in a moist room for more than 4 hours. If stored in a moist room, the plaster caps shall be protected against water dripping on their surfaces.

Capping Procedure

High-Strength Gypsum Plaster:

1. Mix the material at the same percent of mixing water as used for qualification tests.
2. Rapidly spread the capping material on the capping plate.
3. Immediately place the specimen on the capping material, using guide plates or a bulls-eye level to assure perpendicularity of the axis to the capped surface.
4. Carefully isolate each specimen from the surrounding gypsum plaster without disturbing the material coating the end of the specimen (scribing around the perimeter with the finger is effective).
5. Allow material to harden sufficiently to avoid damage during removal from the capping plate.

Capping with High-Strength Gypsum Cement Paste



COMPRESSIVE STRENGTH TEST REPORT

CLIENT: Advanced Professional Eng.

363 West Drake, Suite 10

Port Collins, CO 80526

PROJECT NAME: Port Collins Zoo - Prims

1222 Colorado St.

Port Collins, CO 80525

DDO FFF NNN

PROJECT NO.: S91003-24

DATE CAST: 2/28/2003

TECHNICIAN: Harvey

SAMPLE LOCATION: Caisson A-3-1, plains regions animal habitat

| SAMPLE NUMBER | DATE TESTED | AGE (Days) | LOAD (lbs) | AREA (sq. in.) | STRENGTH (psi) | % OF DESIGN | FACTURE TYPE |
|---------------|-------------|------------|------------|----------------|----------------|-------------|--------------|
| 123-1-2-9 | | hold | | | | | S9100 |
| 123-1-2-2 | 3/7/03 | 7 | 76000 | 28.27 | 2685 | 134% | S9100 |
| 123-1-2-3 | 3/7/03 | 7 | 98000 | 28.27 | 3465 | 173% | S9100 |
| 123-1-2-4 | 3/28/03 | 28 | 120300 | 28.27 | 4255 | 106% | S9100 |
| 123-1-2-5 | 3/28/03 | 28 | 119700 | 28.27 | 4230 | 106% | S9100 |
| 123-1-2-6 | 3/28/03 | 28 | 117100 | 28.27 | 4140 | 104% | S9100 |

NOTE: Some information on this test report provided by others. Testing and reporting was conducted in general accordance with the following applicable ASTM references: C31, C199, C128, C143, C172, C173, C231, C266, C1098 & C1064

Supplier: MJ-Mix

Truck No.: 6100

Ticket No.: 8343

Design Str.: 4000 psi

Product No.: J000-C

Batch Time: 10:15 AM

Sample Time: 0:45 AM

Concrete Temp.: 62° F

Ambient Temp.: 64° F

Slump: 6.5 in.

Air Content: 2.3 %

Unit Weight: 145 pcf

Field Cured: 2 day(s)

Sample Type: Cylinder

Sample Size: 6 in. dia.

REMARKS: none

first cage broke

during placement

used another

Copies To:

Cage Construction

Jungle Jazz Architects

New Holdings

Major Mix

City of Port Collins

Grandview Metropolitan

TYPES OF FRACTURE

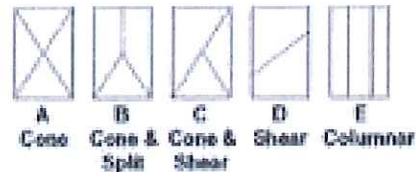

By: _____

Assignment No. 1

NOTICE: The user of this report shall consider the data and information contained in this report to be proprietary. The information is intended only for the use of the recipient(s) named herein. Test results presented herein relate only to those items tested. This document and any information contained herein shall not be disclosed and shall not be duplicated or used in whole or in part for any purpose other than to validate test results without written approval from _____.

Section 5: Apparatus

5.1 Testing Machine – shall be of a type having sufficient capacity and capable of providing the rates of 0.25 ± 0.05 MPa/s (35 ± 7 psi/s). (Section 7.5)

Verify calibration of the testing machine in accordance with ASTM E4, except that the verified loading range shall be as required in section 5.3. Verification is required under the following conditions:

- At least annually, but not to exceed 13 months
- On original installation or immediately after relocation
- Immediately after making repairs or adjustments that affect the operation of the force applying system or the values displayed on the load indicating system, except for zero adjustments that compensate for the mass (weight) of tooling or specimen or both; or
- Whenever there is reason to suspect the accuracy of the indicated loads.

Design – The design of the machine must include the following features:



Power-operated and must apply the load continuously, and without shock. If the machine has only one loading rate (meeting the requirements of T22 section 7.5, it must be provided with a supplemental means for loading at a rate suitable for verifications. This supplemental means of loading may be power or hand-operated.

- Space to accommodate an Eleatic calibration device (circular proving rings or load cells) that is of sufficient capacity to cover the potential loading range of the testing machine.

Accuracy –

- The percentage of error for the loads within the proposed range of use of the testing machine shall not exceed ± 1.0 percent of the indicated load.
- Shall be verified by applying five test loads in four approximately equal increments in ascending order. The difference between any 2 successive test loads shall not exceed one third of the difference between the maximum and minimum test loads.
- The test load as indicated by the testing machine and the applied load computed from the readings of the verification device shall be recorded at each test point. Calculate the error, E, and the percentage of error, Ep, for each point from these data as follows:
 - $E = A - B$
 - $E_p = 100(A - B)/B$

A = Load, kN (or lbf) indicated by the machine being verified; and

B = applied load, kN (or lbf) as determined by the calibrating device

- The report on the verification of a testing machine shall state within what loading range it was found to conform to specification requirements rather than reporting a blanket acceptance or rejection. In no case shall the loading range be stated as including loads below the value that is 100 times the smallest change of load that can be estimated on the load-indicating mechanism of the testing machine or loads within that portion of the range below 10 percent of the maximum range capacity.
- In no case shall the loading range be stated as including loads outside the range of loads applied during the verification test.
- The indicated load of a testing machine shall not be corrected either by calculation or by the use of a calibration diagram to obtain values within the required permissible variation.
- The testing machine shall be equipped with two steel bearing blocks with hardened faces (NOTE 3), one of which is a spherically seated block that will bear on the upper surface of the specimen and the other a solid block on which the specimen shall rest. Bearing faces of the blocks shall have a minimum dimension at least 3 percent greater than the diameter of the specimen to be tested. Except for the concentric circles described below, the bearing faces shall not depart from a plane by more than 0.02 mm (0.001 in.) in the diameter of any smaller block; and new blocks shall be manufactured within one half of this tolerance. When the diameter of the bearing face of the spherically seated block exceeds the diameter of the specimen by more than 13mm (0.5 in.), concentric circles not more than 0.8mm (0.03in.) deep and not more than 1mm (0.04in.) wide shall be inscribed to facilitate proper centering.
 - **NOTE 3:** it's desirable that Bearing faces of blocks used for compression testing of concrete have a Rockwell hardness of not less than 55HRC.

Bottom bearing blocks shall conform to the following requirements:

- The bottom bearing block is specified for the purpose of providing a readily machineable surface for maintenance of the specified surface conditions (note4). The top and bottom surfaces shall be parallel to each other. Its least horizontal dimension shall be at least 3 percent greater than the diameter of the specimen to be tested. Concentric circles, as described in section 5.2, are optional on the bottom block.

Note 4: The block may be fastened to the platen of the testing machine.

- Final centering must be made with reference to the upper spherical block when the lower bearing block is used to assist in centering the specimen. The center of the concentric rings, when provided or the center of the block itself must be directly below the center of the spherical head. Provision shall be made on the platen of the machine to assure such a position.
- The bottom bearing block shall be at least 25mm (1in.) thick when new and at least 22.5mm *0.9) thick after resurfacing operations.
 - **Note 5:** If the testing machine is so designed that the platen itself can be readily maintained in the specified surface condition, a bottom block is not required.

The spherical seated bearing block shall conform to the following requirements:

- The maximum diameter of the bearing face of the suspended spherically seated block shall not exceed the values given in Table1.

TABLE 1 – Maximum diameter of Bearing Face

| Diameter of Test Specimens, mm (inch) | Max Diameter of Bearing Face mm (inch) |
|--|---|
| 50 (2) | 105 (4) |
| 75 (3) | 130 (5) |
| 100 (4) | 165 (6.5) |
| 150 (6) | 255 (10) |
| 200 (8) | 280 (11) |

NOTE 6: Square bearing faces are permissible, provided the diameter of the largest possible inscribed circle does not exceed the above diameter.

- The center of the sphere shall coincide with the surface of the bearing face within a tolerance of ± 5 percent of the radius of the sphere. The diameter of the sphere shall be at least 75 percent of the diameter of the specimen to be tested.
- The ball and the socket shall be designed so that the steel in the contact area does not permanently deform when loaded to the capacity of the test machine.
 - **NOTE 7:** The preferred contact area is in the form of a ring (described as “preferred bearing area”) as shown in Figure 1.

- At least every six months, or as specified by the manufacturer of the testing machine, clean and lubricate the curved surfaces of the socket and of the spherical portion of the machine. The lubricant shall be a petroleum-type oil such as conventional motor oil or as specified by the manufacturer of the testing machine.
 - NOTE 8:** To ensure uniform seating, the spherically seated head is designed to tilt freely as it comes into contact with the top of the specimen. After contact, further rotation is undesirable. Friction between the socket and the spherical portion of the head provides restraint against further rotation during loading. Petroleum-type oil such as conventional motor oil has been shown to permit the necessary friction to develop. Pressure-type greases can reduce the desired friction and permit undesired rotation of the spherical head and should not be used unless recommended by the manufacturer of the testing machine.
- If the radius of the sphere is smaller than the radius of the largest specimen to be tested, the portion of the bearing face extending beyond the sphere shall have a thickness not less than the difference between the radius of the sphere and radius of the specimen. The least dimension of the bearing face shall be at least as great as the diameter of the sphere. (See figure 1.)

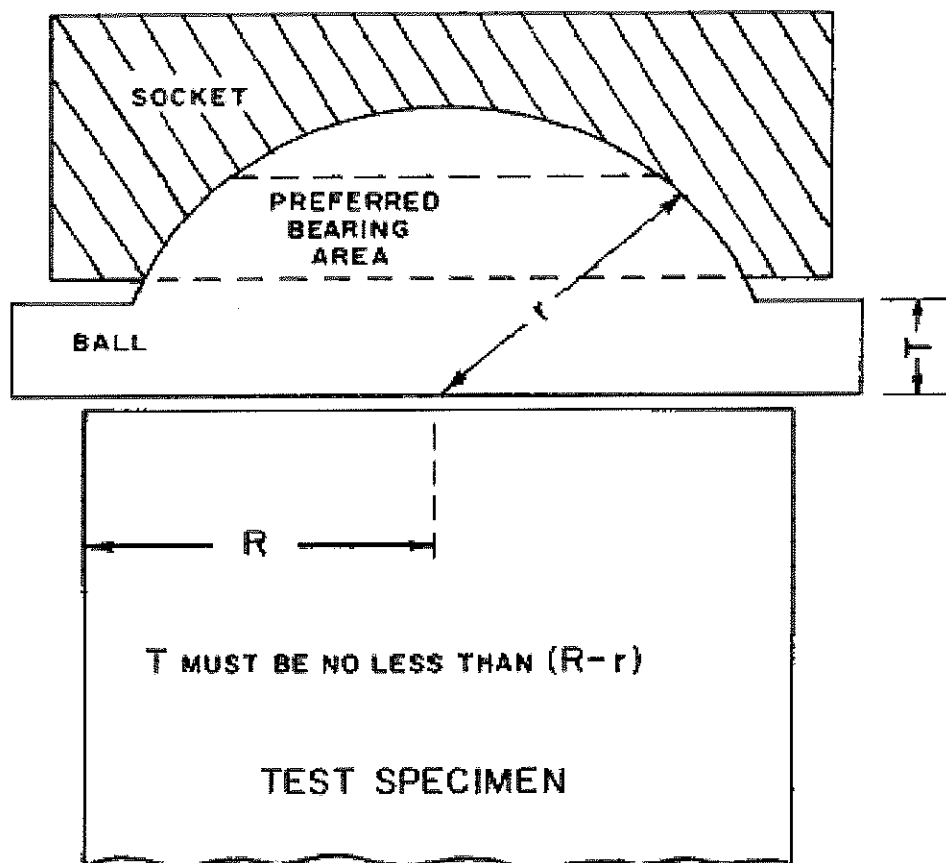

NOTE 1—Provision shall be made for holding the ball in the socket and for holding the entire unit in the testing machine.

FIGURE 1.

- The movable portion of the bearing block shall be held closely in the spherical seal, but the design shall be such that the bearing face can be rotated freely and tilted at least 4 degrees in any direction.
- If the ball portion of the upper bearing block is a two-piece design composed of a spherical portion and a bearing plate, a mechanical means shall be provided to ensure that the spherical portion is fixed and centered on the bearing plate.

Load Indication:

- If the load of a compression machine used in concrete tests is registered on a dial, the dial shall be provided with a graduated scale that can be read to at least the nearest 0.1 percent of the full scale load (Note 9). The dial shall be readable within 1 percent of the indicated load at any given load level within the loading range. In no case shall the loading range of a dial be considered to include loads below the value that is 100 times the smallest change of load that can be read on the scale. The scale shall be provided with a graduation line equal to zero and so numbered. The dial pointer shall be of sufficient length to reach the graduation marks; the width of the end of the pointer shall not exceed the clear distance between the smallest graduations. Each dial shall be equipped with a zero adjustment located outside the dial case and easily accessible from the front of the machine while observing the zero mark and dial pointer. Each dial shall be equipped with a suitable device that at all times, until reset, will indicate to within 1 percent accuracy the maximum load applied to the specimen.

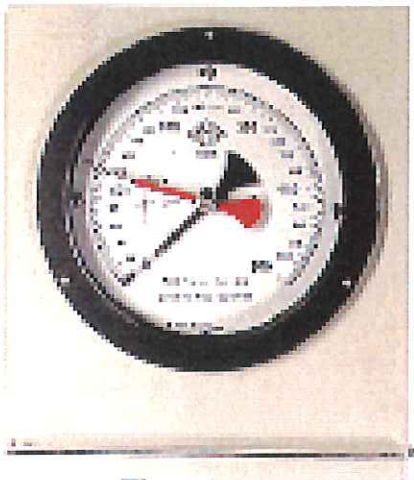

- **Note 9:** Readability is considered to be 0.5mm (0.02 in.) along the arc described by the end of the pointer. Also, one half of the scale interval is about as close as can reasonably be read when the spacing on the load-indicating mechanism is between 1mm (0.04 inch) and 2mm (0.06 inch). When the spacing is between 2mm and 3mm, one-third of a scale interval can be read with reasonable certainty. When the spacing is 3mm or more, one-fourth of a scale interval can be read with reasonable certainty.

- If the testing machine load is indicated in digital form, the numerical display must be large enough to be easily read. The numerical increment must be equal to or less than 0.1 percent of the full-scale load of a given loading range. In no case shall the verified loading range include loads less than the minimum numerical increment multiplied by 100. The accuracy of the indicated load must be within 1.0percent for any value displayed within the verified loading range. Provision must be made for adjusting to indicate true zero at zero load. There shall be provided a maximum load indicator that at all times until reset will indicate within 1.0percent system accuracy the maximum load applied to the specimen.



Rate of Loading Calculation

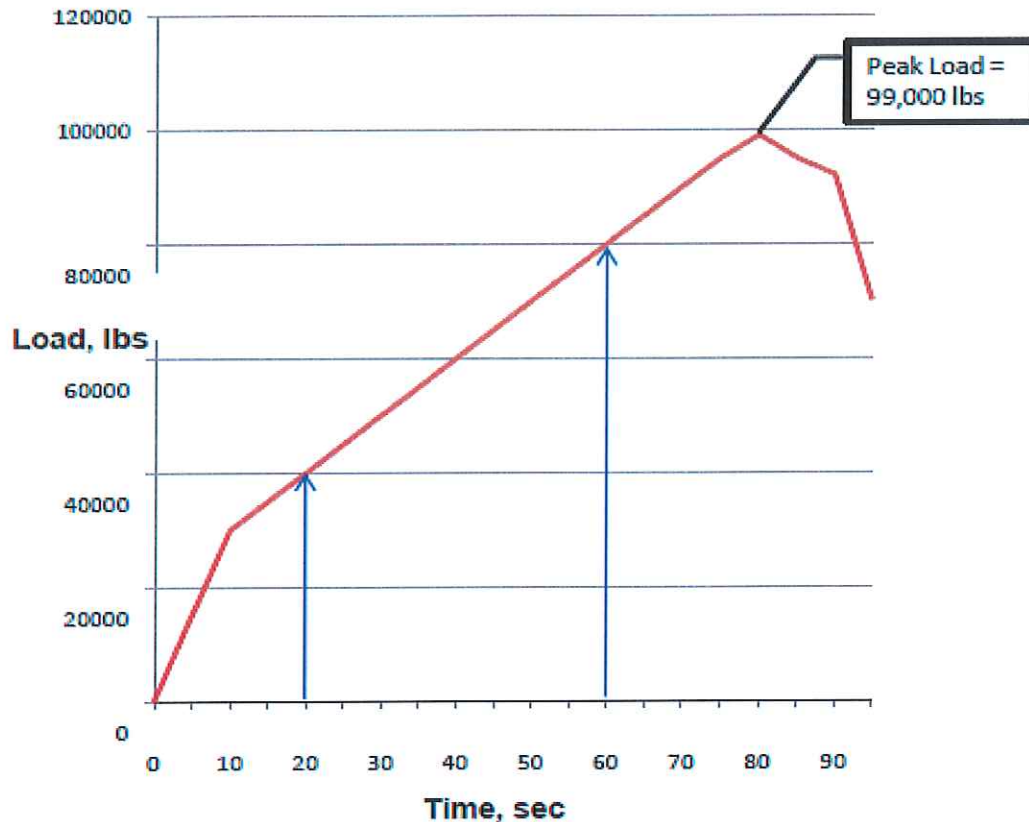

For each 28-day compressive strength test used to determine if specifications are met the rate of loading shall be calculated. Simply providing a graph of Load vs. Time is not enough. It must be determine if the rate of loading 35 ± 7 psi/sec has been met.

1. The rate of loading is the slope of the line on a Load vs. Time plot.

$$\text{Rate of Loading} = \frac{(\text{Increase in Load})}{(\text{Increase in Time}) \times (\text{Cross-sectional Area})}$$

2. Select two points on the line where it's easy to pick numbers off the chart.
 - a. At 20 seconds the load was 40,000 pounds.
 - b. At 60 seconds the load was 80,000 pounds.

$$3. \text{ Rate of Loading} = \frac{(80,000 - 40,000 \text{ lbs})}{(60 - 20 \text{ sec}) \times (28.35 \text{ sq in})} = \frac{40,000 \text{ lbs}}{40 \text{ sec} \times 28.35 \text{ sq in}} = 35.3 \frac{\text{psi}}{\text{sec}}$$

4. Is it a valid test based on rate of loading? Yes.

8. CORES FOR SPLITTING TENSILE STRENGTH

- 8.1. *Test Specimens*—The specimens shall conform to the dimensional requirements in [Sections 7.1, 7.2, 7.4.1, and 7.4.2](#). Ends are not to be capped.
- 8.2. *Moisture Conditioning*—Prior to testing, the specimens shall be conditioned as described in [Section 7.3](#) or as directed by the specifier of tests.
- 8.3. *Bearing Surfaces*—The line of contact between the specimen and each bearing strip shall be straight and free of any projections or depressions higher or deeper than 0.2 mm [0.01 in.]. When the line of contact is not straight or contains projections or depressions having heights or depths greater than 0.2 mm [0.01 in.], grind or cap the specimen so as to produce bearing lines meeting these requirements. Do not test specimens with projections or depressions greater than 2 mm [0.1 in.]. When capping is employed, the caps shall be as thin as practicable and shall be formed of high-strength gypsum plaster.

Note 15—[Figure 1](#) illustrates a device suitable for applying caps to the bearing surfaces of core specimens.

- 8.6. *Precision:*
- 8.6.1. The within-laboratory, single-operator coefficient of variation for splitting tensile strength between 3.6 MPa [520 psi] and 4.1 MPa [590 psi] of cores has been found to be 5.3 percent. Therefore, results of two properly conducted tests by the same operator in the same laboratory on the same sample of material should not differ by more than 14.9 percent of their average.
- 8.6.2. The multilaboratory coefficient of variation for splitting tensile strength between 3.6 MPa [520 psi] and 4.1 MPa [590 psi] of cores has been found to be 15 percent. Therefore, results of two properly conducted tests on the same sample of material of hardened concrete and tested by two different laboratories should not differ from each other by more than 42.3 percent of their average.
- 8.7. *Bias*—Because there is no accepted reference material suitable for determining the bias for the procedure in this test method, no statement on bias is being made.

Qualification of Un-bonded Caps Used for Testing Specimens Over 7,000 PSI Compressive Strength

See the Appendix for:

**Qualification of Un-bonded Caps
Used for Testing Specimens
Over 7,000 PSI Compressive
Strength**

1

Information only: **MODOT** 

When choosing a capping system at MoDOT;

- Drilled cores are sulfur capped (AASHTO T231).
- 28 day Cylinders typically test in the 4000 to 7000psi range, in this case we use Neoprene Pads with Shore A Durometer Hardness of 70. No qualification of pads required. See Table 1
- In rare occasions when testing older cylinders, day 56 or more, when the compressive strength is over 7,000 psi, MoDOT will use sulfur caps (ASHTO T231). Therefore we do not need to qualify unbonded capping systems.

2

Qualification of Unbonded Caps

- This is for testing compressive strength in the range of 7,000 to 12,000 psi when using an unbonded cap system such as the Neoprene Pads.
- *The following slides are for informational purpose to use in your lab when needed.*

3

Sec 8 - Qualification of Unbonded Capping Systems and Verification of Reuse of Pads

8.1

NOTE: *Use qualification of unbonded Neoprene caps when compressive strength is over 7,000 psi.*

Table 1 specifies the conditions under which neoprene unbonded pads must be qualified under this section depending on the concrete strength and the Shore A hardness.

Unbonded pads made of other elastomeric materials must be qualified using the procedures in this section.

4

8.2

When qualification tests are required, they must be made by either the supplier or user of the unbonded pads.

The user of the pads must retain a copy of the current qualification test report to demonstrate compliance with this practice.

8.3

The compressive strength of molded cylinders tested with unbonded caps shall be compared with that of companion cylinders tested with ends ground or capped to meet requirements of AASHTO T22 and AASHTO T231.

Qualification

5

8.4

To be acceptable, tests must demonstrate that at a 95% confidence level ($\alpha = 0.05$), the average strength obtained using unbonded caps is not less than 98% of the average strength of companion cylinders capped or ground in accordance with AASHTO T22 and T231.

8.4.1

When required, qualification test in accordance with 8.5, shall be made on initial use of an unbonded cap at both the highest and lowest strength levels anticipated, to establish an acceptable range of cylinder strength for use.

Qualification

6

In practice, individual cylinders shall not have strengths more than 10% greater than the high strength level or more than 10% less than the low strength level qualified or specified in Table 1.

Qualification tests shall be repeated when one of the following occur:

- A. When there is a change in the design or dimensions of the retaining rings
- B. When there is a change in pad composition or thickness.
- C. When the Shore A hardness changes by more than five units.

Initial qualification tests shall include verification that after the specified maximum number of reuses the pads meet the requirements of 8.4.

Qualification

7

8.4.2

Laboratories must maintain records of the number of times pads are reused.

Section 8.5 – Specimen Preparation for Qualification and Pad Reuse Testing:

8.5.1

Pairs of individual cylinders shall be made from a sample of concrete and cured as nearly alike as possible: One cylinder per pair is to be tested after grinding or capping in accordance with AASHTO T22 and AASHTO T231 and the other is to be tested using the unbonded cap system.

Qualification

8

8.5.2

A minimum of 10 pairs of cylinders shall be made at both the highest and lowest strength levels desired or anticipated.

The “strength level” is the average of the strengths of the 20 or more cylinders whose strengths are within a range of 7 Mpa (1000 psi).

The range of strengths permitted in qualification testing to define the strength level is 7MPa (1000 psi), but that in counting number of reuses only cylinders within a range of 14MPa (2000 psi) are included in the reuse count.

Qualification

9

More than one pair of cylinders can be made from a single concrete sample, but cylinders must become from a minimum of two samples made on different days for each concrete strength level.



Qualification

10

Calculation

For each strength level, compute the difference in strength for each pair of cylinders, and compute the average strength of the cylinders with the reference caps and the average strength of the cylinders with unbonded caps as follows:

$$d_i = X_{pi} - X_{si}$$

$$\bar{X}_s = (X_{s1} + X_{s2} + X_{s3} \dots + X_{sn})/n$$

$$\bar{X}_p = (X_{p1} + X_{p2} + X_{p3} \dots + X_{pn})/n$$

11

d_i = difference in strength of a pair of cylinders computed as the strength of the unbonded capped cylinder minus the strength of the cylinder prepared by T231

X_{pi} = cylinder strength using unbonded cap (Neoprene caps)

X_{si} = cylinder strength using practice T231 (Sulfur caps)

n = number of pairs of cylinders tested for the strength level

X_s = average strength of T231 capped cylinders for a strength level and

X_p = average strength of unbonded capped cylinders for a strength level

12

Compute the average difference (\bar{d}) and standard deviation of the difference (S_d), for each strength level, as follows:

$$\bar{d} = (d_1 + d_2 \dots + d_n) / n$$

$$S_d = \left[\sum (d_i - \bar{d})^2 / (n - 1) \right]^{1/2}$$

Calculations

13

To comply with this practice the following relationship must be satisfied:

$$\bar{X}_p \geq 0.98 \bar{X}_s + (t S_d) / (n)^{1/2}$$

where t is the value of "students t" for (n-1) pairs at $\alpha = 0.05$ from table 2.

Calculations

14

Formula for Qualifying Neoprene pads

$$\bar{X}_p \geq 0.98 \bar{X}_s + (t S_d) / (n)^{1/2}$$

X_s = Is the average result of 10 pairs Sulfur caps tested

X_p = Is the average result of 10 pairs of Neoprene caps tested

S_d = Is the standard deviation of the difference between the neoprene caps and sulfur caps tested

n = is the number of cylinder pairs tested

t = [is the, (n-1) = (10-1) = 9, and 9 from the chart is 1.833

15

Table 2 – Values of “t”

| (n-1) | t(α=0.05) ^A |
|-------|------------------------|
| 9 | 1.833 |
| 14 | 1.761 |
| 19 | 1.729 |
| 100 | 1.662 |

^A Use linear interpolation for other values of (n-1) or refer to appropriate statistical tables.

This table includes counts of 10, 15, 20, and 101 for (n-1)

Calculations 16

Sample Report

X1.1.1 Pad Material:
Lot 3342, Shore A = 52, thickness 13mm (0.51 inch).

X1.1.2 Retaining Ring:
Set A manufactured 1-89.

X1.1.3 Concrete Cylinders:
Job 1207, Nos. 1-10, June 2nd to 5th, 2017

X1.1.4 Sulfur Mortar:
Lot 3428, Compressive Strength of 48.2 (6985 psi).

X1.1.5 Age: All tests 28 days.

17

Sample Report and Calculation

| Cylinder Pair | Compressive Strength, psi | | |
|---------------|---------------------------|------------------|---------------|
| | Neoprene Pad | Sulfur Cap | Difference, d |
| 1 | 3605 | 3580 | 25 |
| 2 | 3605 | 3690 | -85 |
| 3 | 3585 | 3595 | -10 |
| 4 | 3570 | 3625 | -55 |
| 5 | 3625 | 3640 | -15 |
| 6 | 3660 | 3740 | -80 |
| 7 | 3750 | 3720 | 30 |
| 8 | 3725 | 3720 | 5 |
| 9 | 3700 | 3725 | -25 |
| 10 | 3805 | 3755 | 50 |
| Averages | \bar{x}_p 3663 | \bar{x}_s 3679 | \bar{d} -16 |
| Std. Dev. | | | sd 46.06 |

Pad Material: Lot 3742, Shore A = 52, Thickness = 0.51"
 Retaining Ring: Set A manufactured 1-87.
 Concrete Cylinders: Job 1207, Nos. 1-10, January 2 to 5, 1987.
 Sulfur Mortar: Lot 3420, Compressive Strength of 6985 psi.
 Test Age: All Tests 28 days age.

18

Summary and Calculation

Summary:

$\bar{X}_s = 3679$ psi
 $\bar{X}_p = 3663$ psi
 $s_d = 46.06$ psi
 $n = 10$
 $t = 1.833$

Calculation:

$$3663 \geq (0.98)(3679) + (1.833)(46.06)/(10)^{1/2}$$
$$3663 > 3632$$

19

Class Problem 1A

$$\bar{X}_p \geq 0.98 \bar{X}_s + (tS_d) / (n)^{1/2}$$

- Does this system (of neoprene pads) qualify for use? Use the following information to determine, Yes or No.

$\bar{X}_s = 3688$ psi
 $\bar{X}_p = 3659$ psi
 $s_d = 51.04$ psi
 $n = 10$
 $t = 1.833$

20

Answer 1A

$$\bar{X}_p \geq 0.98 \bar{X}_s + (tS_d) / (n)^{1/2}$$

$$3659 \text{ psi} \geq (0.98 \times 3688) + (1.833 \times 51.04) / (10)^{1/2}$$

$$3659 \text{ psi} \geq 3614 + (93.56 / 3.162)$$

$$3659 \text{ psi} \geq 3614 + 29.59$$

$$3659 \text{ psi} \geq 3644 \text{ psi}$$

The answer is YES these neoprene pads qualify for use.

21

Glossary



Concrete Glossary of Terms

AASHTO

American Association of State Highway and Transportation Officials

Aggregate Correction Factor

An easily run test that accounts for air in the aggregate structure which fills with water under pressure. It is determined on inundated fine and coarse aggregate in approximately the same moisture condition, amount and proportions occurring in the concrete sample under test.

Air Content

The amount of air in mortar or concrete, exclusive of pore space in the aggregate particles, usually expressed as a percentage of total volume of mortar or concrete.

Air Void

A space in cement paste, mortar, or concrete filled with air, and entrapped air void is characteristically 1mm (0.04 in.) or more in size and irregular in shape; an air entrained air void is typically between 10µm and 1mm in diameter and spherical (or nearly so).

Batch Weights

Quantity of concrete or mortar mixed at one time.

Central Mixed Concrete

A stationary concrete mixer from which the fresh concrete is transported to the work.

Compression Test

Test made on a specimen of mortar or concrete to determine the compressive strength; unless otherwise specified, compression tests of mortars are made on 50mm (2 in.) cubes, and compression tests of concrete are made on cylinders either 4 inches in diameter and 8 inches in height or 6 inches in diameter and 12 inches in height.

Compressive Strength

The measure resistance of a concrete or mortar specimen to axial loading; expressed as pounds per square inch (psi) of cross-sectional area.

Concrete

A composite material that consists essentially of a binding medium in which is embedded particles or fragments of relatively inert material filler. In Portland cement concrete, the binder is a mixture of Portland cement and water; the filler may be any of a wide variety of natural or artificial aggregates.

Consistency

The relative mobility or ability of fresh concrete or mortar to flow. The usual measures of consistency are slump or ball penetration for concrete and flow for mortar.

Consolidation

The process of inducing a closer arrangement of the solid particles in freshly mixed concrete or mortar during placement by the reduction of voids, usually by vibration, centrifugation, tamping, or some combination of these actions; also applicable to similar manipulation of other cementitious mixtures, soils, aggregates, or the like.

Core

A cylindrical specimen of standard diameter drilled from a structure or rock foundation to be tested in compression or examined petrographically.

Entrained Air

Round, uniformly distributed, microscopic, non-coalescing air bubbles entrained by the use of air-entraining agents; usually less than 1mm (.04 in.) in size.

Entrapped Air

Air in concrete that is not purposely entrained. Entrapped air is generally considered to be large voids (larger than 1mm [.04 in.]).

Field Cured Cylinders

Test cylinders cured as nearly as practicable in the same manner as the concrete in the structure to indicate when supporting forms may be removed, additional loads may be imposed, or the structure may be placed in service.

Finishing

Leveling, smoothing, compacting, and otherwise treating surfaces of fresh or recently placed concrete or mortar to produce desired appearance and service.

Gradation

The distribution of particles of granular material among various sizes, usually expressed in terms of cumulative percentages larger or smaller than each of a series of sizes (sieve openings) or the percentages between certain ranges of sizes (sieve openings).

Length Measurement

The longitudinal measurement taken along the specimen axis

Modulus of Rupture

An ultimate strength pertaining to the failure of beams by flexure equal to the bending moment at rupture divided by the section modulus of the beam

Pad

An unbonded elastomeric pad

Plasticity

The property of fresh concrete or mortar which determines its resistance to deformation or its ease of molding.

PSI

Pounds per square inch; a measurement of the compressive, tensile or flexural strength of concrete as determined by appropriate test.

Pumping

The forceful displacement of a mixture of soil and water that occurs under slab joints, cracks, cracks and pavement edges which are depressed and released quickly by high-speed heavy vehicle loads; occurs when concrete pavements are placed directly on fine-grained, plastic soils or erodible sub base materials.

Quality Assurance

Planned and systematic actions by an owner or his representative to provide confidence that a product or facility meet applicable standards of good practice. This involves continued evaluation of design, plan specification development, contract advertisement and award, construction, and maintenance, and the interactions of these activities.

Quality Control

Actions taken by a producer or contractor to provide control over what is being done and what is being provided so that the applicable standards of good practice for the work are followed.

Rebar

Abbreviation for "Reinforcing Bar." Bars, wires, strands, and other slender members embedded in concrete in such a manner that the reinforcement and the concrete act together in resisting forces.

Rod, Tamping

A straight steel rod of circular cross section having one or both ends rounded to a hemispherical tip.

Rodding

Compaction of concrete by means of a tamping rod.

Sample

A group of units, or portion of material, taken from a larger collection of units or quantity of material, which serves to provide information that can be used as a basis for action on the larger quantity or the production process; the term is also used in the sense of a sample of observations.

Slump

A measure of consistency of freshly mixed concrete, equal to the subsidence measured to the nearest 6mm (¼ in.) of the molded specimen immediately after removal of the slump cone.

Standard Cure

The curing method used when specimens are intended for acceptance testing for specified strength, checking the adequacy of mixture proportions for strength, quality control.

Strike off

To remove concrete in excess of that required to fill the form evenly or bring the surface to grade; performed with a straight edged piece of wood or metal by means of forward sawing movement or by a power operated tool appropriate for this purpose; also the name applied to the tool.

Tamping

The operation of compacting freshly placed concrete by repeated blows or penetrations with a tamping device.

Thickness Measurement

The length measurement of a core taken perpendicular to the driving surface of a pavement.

Three Point Caliper

A device used to determine the length of a cylindrical shaped specimen consisting of three resting points and a means of evenly measuring nine different points on the opposite end.

Truck-Mixed Concrete

Concrete, the mixing of which is accomplished in a truck mixer

Unbonded Cap

A metal retainer and an elastomeric pad