

PART PLAN OF DEVICE
LA TYPE B BARRIER (SBC)

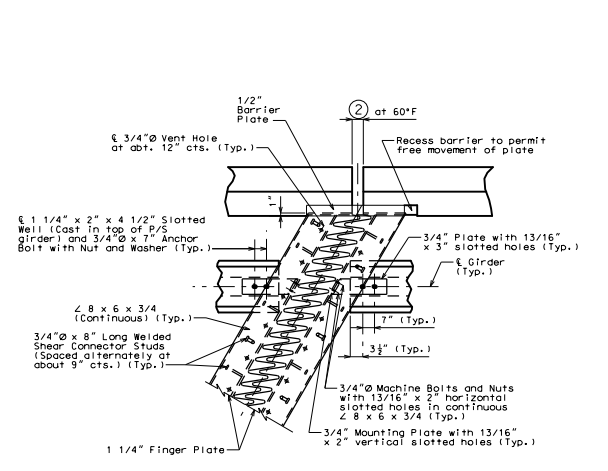

PART PLAN OF DEVICE
LA TYPE D BARRIER

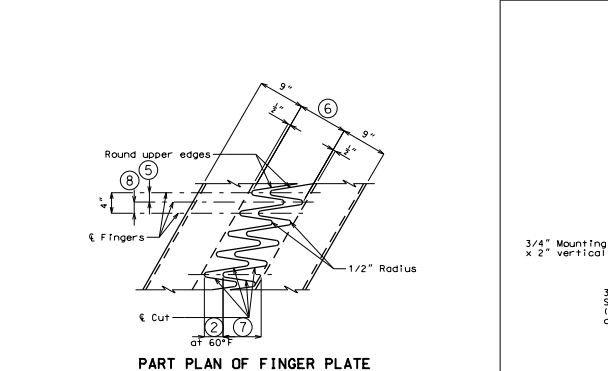

PART PLAN OF FINGER PLATE
LA

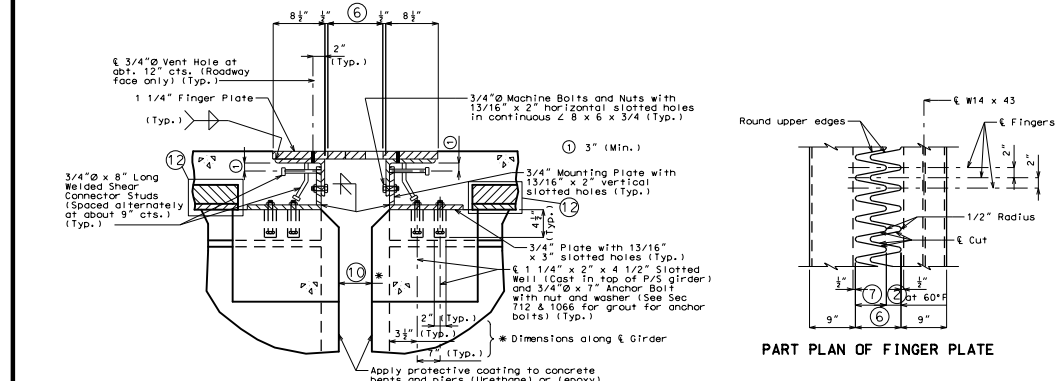

SECTION THRU DEVICE
RA TYPE B BARRIER (SBC)

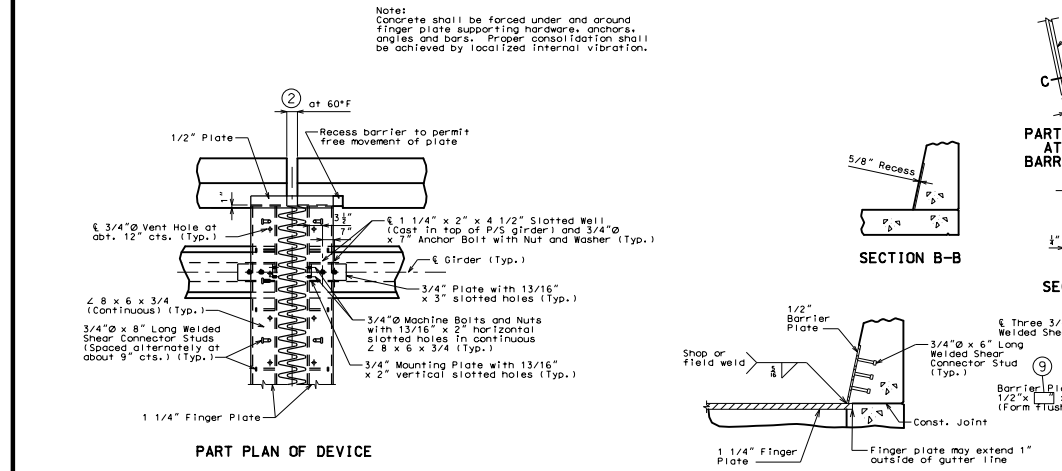

PART PLAN OF DEVICE
RA TYPE D BARRIER

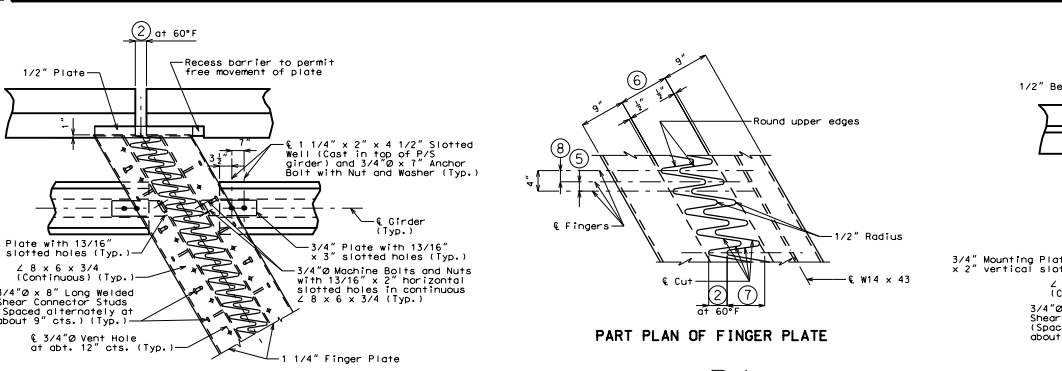

PART PLAN OF DEVICE
RA TYPE B BARRIER (SBC)

GENERAL NOTES:
Finger plate shall be cut with a machine guided gas torch from one plate. The plate from which fingers are cut may be spliced before fingers are cut. The surface of cut shall be perpendicular to the surface of the plate. The cut shall not exceed 1/8" in width. The centerline of cut shall not deviate more than 1/16" from the position of centerline of cut shown. No splicing of finger plate or finger plate assembly will be allowed after fingers are cut. The expansion device shall be fabricated and installed to the crown and grade of the roadway.
Plan dimensions are based on installation at 60°F. The expansion gap, and other dimensions shall be increased or decreased for each 10° fall or rise in temperature of installation.
Material for the expansion device shall be ASTM A709 Grade 36 structural steel. Anchors for the expansion device shall be in accordance with Sec 1037.
Structural steel for the expansion device and barrier plate shall be coated with a minimum of two coats of inorganic zinc primer to provide a total dry film thickness of 4 mils minimum, 6 mils maximum, or galvanized in accordance with ASTM A123. Anchors need not be protected from over spray.
Payment for furnishing, coating or galvanizing and installing the structural steel for the expansion device will be considered completely covered by the contract unit price for Expansion Device (Finger Plate) per linear foot.
Longitudinal reinforcing steel shall be placed so that ends shall not be more than 21" from the 3/4" vertical mounting plate of the expansion device.
Complete joint penetration welds utilized in the fabrication of the expansion device shall be nondestructively tested by an approved method.

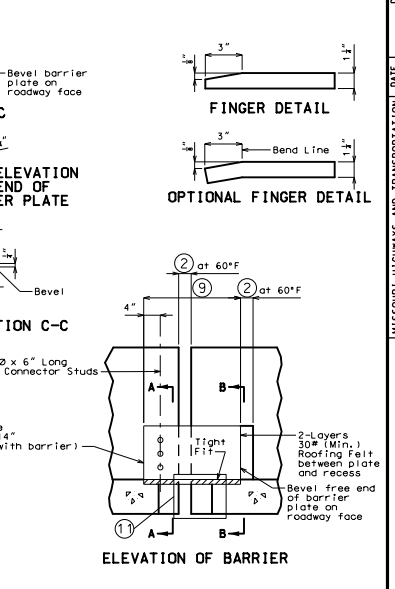

PART ELEVATION AT END OF BARRIER PLATE
ELEVATION OF BARRIER

DATE PREPARED	8/5/2020
ROUTE	STATE
DISTRICT	MD
BR	*
COUNTY	*
JOB NO.	*
CONTRACT NO.	*
PROJECT NO.	*
BRIDGE NO.	FING02
DESCRIPTION	
DATE	
MISSOURI HIGHWAYS AND TRANSPORTATION COMMISSION	
100 WEST CAPITAL	
JEFFERSON CITY, MISSOURI 64581	
1-888-542-4688	

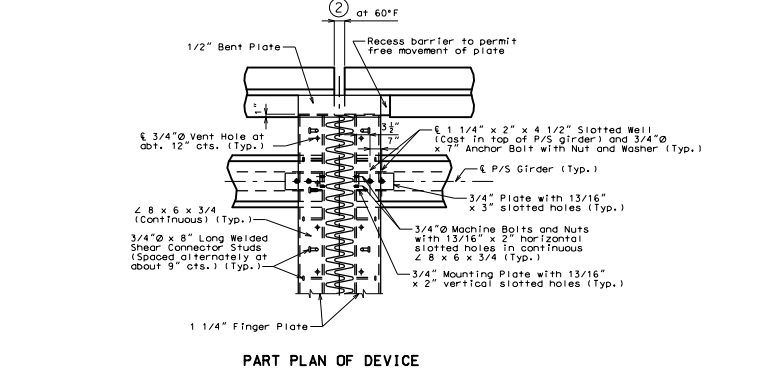

PART PLAN OF DEVICE
SQ TYPE B BARRIER (SBC)

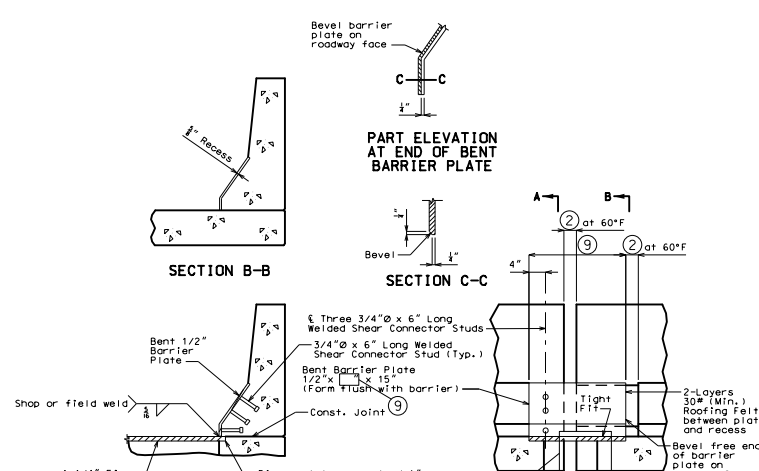

PART ELEVATION AT END OF BENT BARRIER PLATE
ELEVATION OF BARRIER

TYPE B BARRIER (SBC) (ALL)

- STANDARD DRAWING GUIDANCE (do not show on plans):
(For all finger plate drawings. Some notes may not apply to this sheet.)
- Not a guidance note. Do not replace.
 - Gap between fingers, barrier recess gap and, for intermediate bents, gap in barrier.
 - For end bents: $2 + 1/2 / \cos(\text{skew})$
 - Gap adjustment for temperature: along bridge longitudinal axis
 - Transverse gap between fingers
 - Maximum gap between fingers normal to joint @ 60°F.
 - Finger length.
 - Transverse gap between fingers: not the same as 5 for skewed joints.
 - Plate length = $(18 + 6) / \cos(\text{skew})$
 - Gap between girder or between girder and end bent.
 - Include details of slab projection beyond W-beam under barrier on plan of slab detail sheet. Consider similarly projection beyond front face of angle under barrier at end bents.
 - Delete panel for CIP slab.