



IMPROVE I-70 MONTHLY REPORT

Missouri's FY2024 budget from the General Assembly and signed into law by Governor Parson provides General Revenue for the costs to plan, design, construct, reconstruct, rehabilitate and repair three lanes in each direction on nearly 200 miles of Interstate 70, from Blue Springs to Wentzville.

STAY IN THE KNOW: www.modot.org/improvei70



IMPROVE 70 ALLIANCE TEAM SELECTED AS BEST-VALUE PROPOSER FOR IMPROVE I-70: WARRENTON TO WENTZVILLE PROJECT



The Missouri Highways and Transportation Commission (MHTC) has selected **Improve 70 Alliance Joint Venture** (Emery Sapp & Sons, Clarkson Construction Company, HNTB, and Bartlett & West) as the apparent best-value proposer and Design-Build contractor of the next project in MoDOT's Improve I-70 Program. Negotiations to finalize the contract are currently in progress. Improve I-70: Warrenton to Wentzville is a \$600 million fixed-cost contract and is the largest project in MoDOT history. It will build a third lane in each direction and improve the stretch of Interstate 70 from Warrenton to I-64 in Wentzville beginning in Spring 2025. The contract requirements also include the following additional improvements:

- Interchange and outer road improvements in Wright City
- Realignment at the railroad bridge on I-70 between Wentzville Parkway and Route Z
- Interchange improvements at I-70 and I-64/Route 61
- Add a third lane of travel to eastbound and westbound I-64 between I-70 and Route K
- Bridge replacement in Foristell

PROJECT GOALS

- Deliver the project within the program budget of \$600 million.
- Provide an additional lane of travel in each direction on I-70 from Warrenton to I-64, and on I-64 from I-70 to Route K.
- Improve the I-70/I-64/U.S. Route 61 interchange to provide for better traffic flow and safety.
- Modernize I-70 while improving the existing pavement, bridges, and interchanges to enhance mobility, including freight.
- Minimize construction impacts with a focus on work zone safety, communication, and construction staging while maintaining mobility.
- Complete the project by December 2028 utilizing a diverse work force.

The Warrenton to Wentzville project includes the Improve I-70 funding as well as funding previously allocated for other I-70 and I-64 projects and additional legislatively dedicated funding to reach the total contract cost of \$600 million.

“Today’s contractor selection highlights MoDOT’s determination to continue to fulfill this generational opportunity to improve I-70, which serves as a critical economic east-west corridor across Missouri,” explained MHTC Chairman Dustin Boatwright. “This project will not only improve I-70, but it is also an opportunity to make other necessary improvements to I-70 and other routes and interchanges in the St. Charles and Warren County area. These improvements will continue to serve these growing communities for many years to come.”

NOVEMBER 2024

IMPROVE I-70 MONTHLY REPORT



The next steps include finalizing the contract and the contractor team will be doing more detailed design of the roadway and interchanges and the construction schedule with traffic control plans. MoDOT will host public information meetings in early 2025 as these details are ready. Construction is scheduled to begin in spring 2025 with an anticipated completion in late 2028. For more information, renderings, and a fly through video, visit www.modot.org/improvei70/warrentonwentzville.

PROPOSED MAINLINE I-70 TYPICAL SECTION

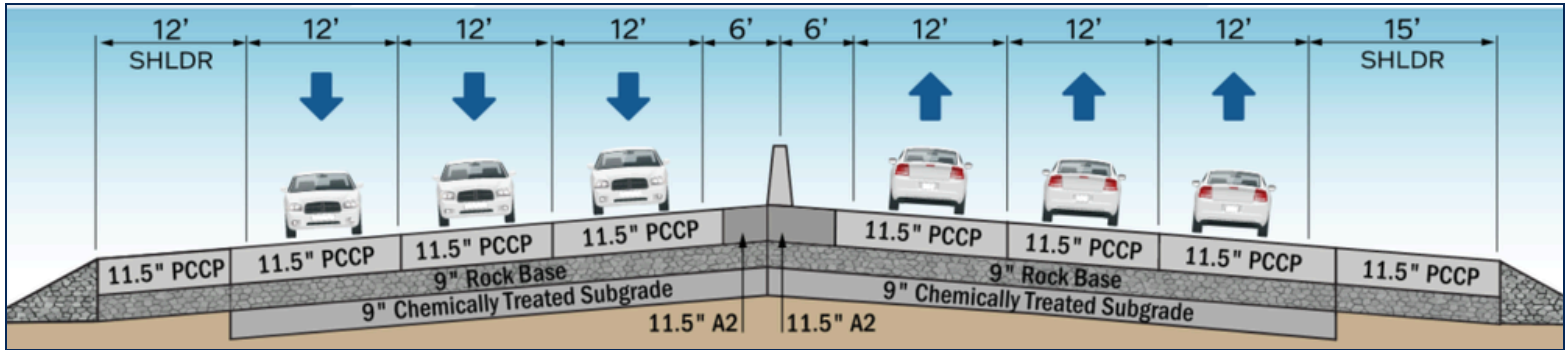

PROPOSED MAINLINE I-64 TYPICAL SECTION

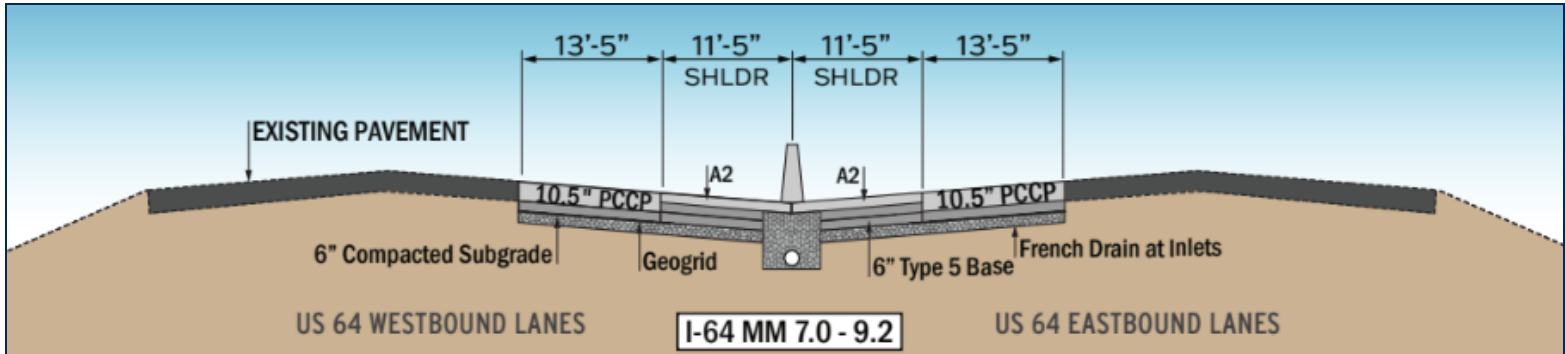

PROPOSED I-70 & I-64/U.S. 61 INTERCHANGE



WINNING PROPOSAL INCLUDES:

- Constructs a third lane in each direction on I-70 from Warrenton to I-64 in Wentzville, including replacing the existing I-70 lanes with new full-depth concrete pavement.
- Interchange improvements at I-70 and the I-64/Route 61 interchange.
- Interchange and outer road improvements in Foristell, Wright City, Warrenton, and at Route Z.
- Realignment at the railroad bridge on I-70 between Wentzville Parkway and Route Z.
- Addition of a third lane of travel to eastbound and westbound I-64 between I-70 and Route K.
- The team has also committed to keeping two lanes of travel open on I-70 in both directions during peak travel times.

Additional renderings and project plans will be available at the public information meetings tentatively scheduled to be held in early 2025. Meeting dates will be announced soon. More details can also be found at www.modot.org/improvei70/warrentonwentzville



STAY IN THE KNOW: www.modot.org/improvei70